

**UPPER DUBLIN TOWNSHIP
MONTGOMERY COUNTY, PENNSYLVANIA**

**ENGINEERING AND CONSTRUCTION STANDARDS,
IMPROVEMENTS PROCEDURES**

**JANUARY 2010
Revised OCTOBER 2013**

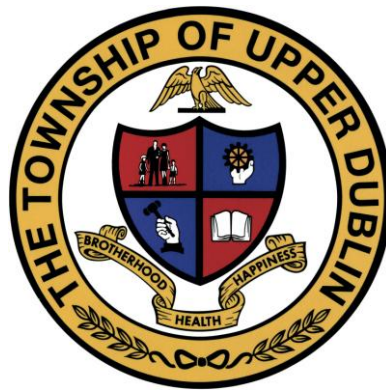

TABLE OF CONTENTS

I.	PROCEDURES	3
	A. General	3
	B. Notification to Township	3
	C. Notification to Adjoining Neighbors	3
	D. Pre-construction Meeting	3
	E. Permits and Certificates	3
	F. Traffic Control and Safety	5
	G. Inspections	5
	H. Drafting Standards	12
II.	STANDARDS OF CONSTRUCTION	13
	A. Streets	13
	B. Curb and Sidewalk	26
	C. Storm Drainage Pipe Materials	28
	D. Storm Drainage Appurtenances	30
	E. Materials for Trench Backfill	30
	F. Storm Drainage Detention/Retention Basins	31
	G. Underground Detention/Groundwater Recharge	33
	H. Geotextiles	33
	I. Signs and Markings	34
	J. Township Road Access by Driveways and Parking Areas	35
	K. Lighting	37
	L. Sanitary Sewer	37
	M. Traffic Signals	37
	N. Miscellaneous Standards	63
III.	APPENDICES	
	A. Policies and Procedures	
	B. Deferral of Improvement Notes	
	C. Acknowledgements	
	D. Certifications	
	E. Subdivision and Land Development Document Checklist	
	F. As-Built Plan Requirements	
	G. Pre-Construction Meeting Agenda/Checklist	
	H. Construction Details	

I. PROCEDURES

A. General

This Standard details the procedures and standards for constructing improvements in Upper Dublin Township.

B. Notification to Township

The Upper Dublin Township Board of Commissioners or duly assigned representative shall be notified prior to the start of any construction and/or grading, excavation; including removal of topsoil, grubbing of shrubs, bushes, trees and vegetation of any kind, performance of any work in a street, right-of-way, utility easement, storm drainage easement, waterways, or performance of work in an approved subdivision or land development in Upper Dublin Township.

C. Notification to Adjoining Neighbors

Developer or person subdividing or developing property shall prepare a list of adjoining property owners or owners affected, but not immediately adjoining, and submit for approval to the Township Engineer. Upon approval of the Township Engineer, the developer or person subdividing or developing the property shall notify these owners by U.S. mail at least two (2) weeks prior to the start of construction. Provide a copy of such notice to Upper Dublin Township and Township Engineer.

D. Pre-construction Meeting

A Pre-construction Meeting will be required for all Subdivision and Land Developments where improvements are required, and for any other construction or earthmoving activities when deemed necessary by the Township Commissioners, Public Works Director, or Township Engineer. The developer, contractor and sub-contractors who will be performing the work are to attend, along with the Township Engineer and Township representatives, Montgomery County Conservation District, as well as any other interested reviewing agencies and/or utilities. A Pre-Construction Meeting Agenda and Checklist is included in Appendix G. The Township Engineer will publish minutes of the meeting for those attending.

E. Permits and Certificates

Proof of all required permits, certifications and approvals shall be provided prior to the Pre-construction Meeting, as well as compliance with the utility notification requirement per Pennsylvania Act No. 38. Developer shall provide the PA One Call Serial Number to the Township as evidence of compliance. Construction may not commence until all permits and approvals are obtained. All permit applications shall be made by the property owner or jointly with the contractor.

Developer or owners are required to provide a Schedule detailing the expiration of any permits or approvals and submit the required extensions, with copies to the township. **COPIES OF ALL PERMITS AND APPROVED CONSTRUCTION PLANS SHALL BE KEPT ON-SITE AT ALL TIMES.**

Any and all applications, permits or connection fees shall be paid at the time of application and shall be in the amount as established by ordinance of the Board of Commissioners or applicable utility as in effect at the time of application.

A general list of permits and/or approvals, which is not all-inclusive or limited, is shown in Table 1 below.

TABLE 1 - PERMITS OR APPROVALS AND RELATED AGENCIES

Permits or Approvals	Agency
Stream Encroachment, Waters of the Commonwealth	PADEP, Army Corp of Engineers, PA Fish and Boat Commission
Wetlands and/or Floodplain Encroachments	PADEP, Army Corp of Engineers
Water Quality	PADEP, Delaware River Basin Commission
State Highway Access and/or Occupancy	PennDOT, Upper Dublin Township
County Street Access Utility and/or Occupancy	Montgomery County, Department of Roads and Bridges, Upper Dublin Twp.
Township Street Encroachment	Upper Dublin Township
Township Grading Permit	Upper Dublin Township & Montgomery County Conservation District
Grading, Soil Erosion & Sediment Control	Montgomery County Conservation District
Stormwater Management Permit	Upper Dublin Township
Sanitary Sewer Connections and Installations	Upper Dublin Township
Water Connection and/or Installation	Bucks County Water and Sewer Authority
Planning Module/Sanitary Sewer Extension Permit	Aqua America, North Wales Water Authority or Ambler Water Co.
	PA DEP

F. Traffic Control and Safety

Work being performed on any and all existing public highways, streets, rights-of-way and easements, shall require a Highway Opening Permit and posting of a performance and maintenance bond as may be required from the proper authority. All required safety protection, including flag persons, signing, barricades, flashing warning devices and other required devices shall be provided by Owner/Developer/Contractor. All safety protection methods, devices, and procedures shall be in conformance with Pennsylvania Department of Transportation Publication 203, Work Zone Traffic Control current edition, and will be furnished and maintained solely by the applicant.

All work being performed shall be in compliance with Federal, State and local safety regulations and shall provide for public safety and the safety of all personnel involved directly or indirectly in the construction of all improvements, including, but not limited to trench shoring, protective clothing, safety shields and switches on power equipment, and vehicle alarms. Developer is also cautioned to comply with any applicable OSHA Regulations.

G. Inspections

Inspections shall be performed by the Township or its duly appointed representative unless stated otherwise herein, to guarantee the proper procedures, workmanship, methods of installation of all approved structures, and approved materials required to be installed.

Inspection shall be required prior to starting construction, during the installation of materials and structures, and upon the completion of all improvements. All improvements shall be installed in accordance with the approved plans, the required regulations, and these engineering and construction standards.

Any and all unsatisfactory workmanship, faulty procedures or methods, and defective materials that have been installed, shall be rejected and noted for the record on the inspection standards punchlist and shall be corrected before final acceptance.

The placement of all required improvements shall be in accordance with the controls set under the supervision of a Professional Land Surveyor registered by the State of Pennsylvania, to insure installation of improvements to proper location, elevation, alignment and profile.

The following is intended to describe the format of inspections and notification procedures. Scheduling of required inspections with Township or Township Engineer shall be the responsibility of the owner, and/or his contractor. The Township or appropriate agency is to be notified by the developer or contractor at least two (2) workdays before commencing any work on any item requiring

inspection. Cut sheets for all improvements must be submitted to the Township Engineer (or Township Engineer's representative) at least seventy-two (72) hours prior to construction.

1. Sanitary Sewer System

- a. Shall require visual inspection, section by section, upon completion of that section, prior to backfilling any section including pipes, manholes, laterals, wyes and cleanouts and all items being installed as part of the sanitary sewer system. Inspection will be full-time during backfilling and compacting procedures.
- b. Inspection of the sanitary sewer system (pipe installation and stone backfill to one foot over the pipe) is the responsibility of Bucks County Water and Sewer Authority or their representatives. The owner and/or his contractor shall make all arrangements to adhere to their policies, procedures and standards. The Township is responsible for inspecting trench backfilling compaction and road restoration. The Township Engineer must be contacted at least forty-eight (48) hours in advance of construction. The Township Engineer will inspect all trench backfill for proper compaction one foot above pipe to finished grade.
- c. Full 2A stone backfill, properly compacted in eight (8) inch lifts to 95% compaction, AASHTO Dry Density Method, is required in all trenches within any right-of-way. Reference Upper Dublin Township Typical Trench Detail, latest revision.

2. Water Distribution System (North Wales Water Authority, Aqua America Water Company or Ambler Borough Water Company)

- a. Inspection of all improvements having been installed complete by section, requiring section-by-section pressure test and bacteria test to required standards utilized by the water utility company servicing the Township. The Township is responsible for inspecting trench backfilling and road restoration. The Township Engineer must be contacted at least forty-eight (48) hours in advance of construction. The Township Engineer will inspect all trench backfill for proper compaction one foot above pipe to finished grade.
- b. Full 2A stone backfill, properly compacted in eight (8) inch lifts to 95% compaction, AASHTO Dry Density Method, is required in all trenches within any right-of-way. Reference Upper Dublin Township Typical Trench Detail, latest revision.

3. Storm Sewer System

- a. Shall require visual inspection, section by section, upon completion of that section, prior to backfilling any section including pipes, inlets, manholes, endwalls, detention and retention basins, berms, culverts and bridges, and all items being installed as part of the storm drainage system. Inspection will be full-time during backfilling and compacting procedures.
- b. Cast-in-place concrete structures and bridge structures shall require material samples, in compliance with ASTM C39 Standards and PennDOT Publication 408, PennDOT RC Standards, Current Edition.
- c. Samples must be taken in the presence of the inspector.
- d. Full 2A stone backfill, properly compacted in eight (8) inch lifts to 95% compaction, AASHTO Dry Density Method, is required in all trenches within any right-of-way. Reference Upper Dublin Township Typical Trench Detail, latest revision.

4. Subsoil System

Inspection to determine type of subsoil structure for compaction compatibility for use as a subgrade, including Proctor testing, as may be required.

a. Subgrade Stability Verification

After contractor has prepared subgrade in accordance with PennDOT 408, Section 210 (subgrade), a Subgrade Stability Verification is required prior to placement of subbase material. A triaxle fully loaded maximum load (quarry slip of loaded weight will be required in the field) is required to run over entire roadway subgrade (including curb lines), over all trenches and anywhere directed by Township Engineer or the Township Engineer's representative in the field. Areas displaying pronounced elasticity, pumping, movement or deformation under the loaded triaxle will be noted and marked in the field. The areas noted and/or marked showing unstable subgrade must be corrected and re-verified for required stability prior to starting subbase construction. All areas that are to be filled, stoned, paved and/or curbed are to be proofrolled by this method. A subgrade stability re-verification is required after any/all rain events, snow events (once cleared and/or melted), introduction of moisture to the subgrade or sub-base, or as determined by the Township Engineer or the Township Engineer's representative in the field.

5. Subgrade and Underdrain Pipe

Inspection and soil testing of subgrade type for required density and visual inspection of underdrain pipe installation including all connections to the storm drainage system and service laterals as required.

a. Subgrade Stability Verification

After contractor has prepared subgrade in accordance with PennDOT 408, Section 210 (subgrade), a Subgrade Stability Verification is required prior to placement of subbase material. A triaxle fully loaded maximum load (quarry slip of loaded weight will be required in the field) is required to run over entire roadway subgrade (including curb lines), over all trenches and anywhere directed by Township Engineer or the Township Engineer's representative in the field. Areas displaying pronounced elasticity, pumping, movement or deformation under the loaded triaxle will be noted and marked in the field. The areas noted and/or marked showing unstable subgrade must be corrected and re-verified for required stability prior to starting subbase construction. All areas that are to be filled, stoned, paved and/or curbed are to be proofrolled by this method. A subgrade stability re-verification is required after any/all rain events, snow events (once cleared and/or melted), introduction of moisture to the subgrade or sub-base, or as determined by the Township Engineer or the Township Engineer's representative in the field.

6. Subbase Course

- a. Inspection of materials and placement of subbase prior to installation of base course, including the submittal of all certified material delivery slips, daily, to the inspector on site.
- b. Approval of subbase on day of placement of paving, prior to release of bituminous material from plant. Sub-base will be visually checked with a fully loaded tri-axle, provided by the developer.
- c. Subgrade Stability Verification

After contractor has prepared subgrade in accordance with PennDOT 408, Section 210 (subgrade), a Subgrade Stability Verification is required prior to placement of subbase material. A triaxle fully loaded maximum load (quarry slip of loaded weight will be required in the field) is required to run over entire roadway subgrade (including curb lines), over all trenches and anywhere directed by Township Engineer or the Township Engineer's representative in the field. Areas displaying pronounced elasticity, pumping, movement or deformation under the loaded triaxle will be noted and marked in the field. The areas noted and/or marked showing unstable subgrade must be corrected and re-verified for required stability prior to starting subbase

construction. All areas that are to be filled, stoned, paved and/or curbed are to be proofrolled by this method. A subgrade stability re-verification is required after any/all rain events, snow events (once cleared and/or melted), introduction of moisture to the subgrade or sub-base, or as determined by the Township Engineer or the Township Engineer's representative in the field.

7. Base Course

- a. Inspection of materials placed as base, including the submittal of all certified material weight slips to the inspector on site, daily.
- b. Core tests of base material to be provided by developer at locations indicated in field by engineer or inspector. Testing shall include gradation, density, compaction, percent voids and compliance with design mix.

8. Binder Course

- a. Inspection or re-inspection of previously installed binder course. Inspection of materials placed as binder course, including the submittal of all certified material weight slips to the inspector on site, daily.
- b. Core tests of binder course material to be provided at locations indicated in field by Township Engineer. Testing shall include gradation, density, compaction, percent voids and compliance with design mix.

9. Wearing Course

- a. Inspection of materials placed as wearing course, including the submittals of all material slips to the inspector on site, daily.
- b. Core tests of wearing course material may be required by Township Engineer. Testing shall include gradation, density, compaction, percent voids and compliance with design mix.
- c. If the wearing course is installed more than seven (7) days after the binder course, tack coat must be applied to the road surface prior to the installation of the wearing course per PennDOT Specifications, Publication 408.
- d. Final gutter, joint and structure sealing.

10. Concrete Curb

- a. Inspection of subgrade, general alignment and any forms to be used. Forms must be straight, undented, free of foreign material and may not discolor concrete. Steel forms are required, except as permitted by inspector. String line shall be set and checked by inspector prior to any forming or concrete pour to show line and grade, profile and alignment.
- b. Material inspection, including the submittal of all certified material delivery slips, air entrainment content and slump testing as required. Cylinders may be required and tested at the expense of the developer. Concrete mix designs must meet PennDOT Publication 408.
- c. Inspection of installation and finish shall be in accordance with PennDOT Publication 408.
- d. Machine Formed Curb shall require full-time inspection. Approval of concrete mix to be used with proper additives is required 72 hours prior to pouring.
- e. Penetrating sealer to be immediately applied after finishing operation. Penetrating sealer to be Aquaron CPT 2000 or approved equal.
- f. Weather protection shall be used in accordance with PennDOT Publication 408.

11. Belgian Block/Granite Curb

- a. Inspection of subgrade, general alignment and any forms to be used. Forms must be straight, undented, free of foreign material and may not discolor concrete. Steel forms are required, except as permitted by inspector. String line shall be set and checked by inspector prior to any forming or concrete pour to show line and grade, profile and alignment.
- b. Material inspection, including the submittal of all certified material delivery slips, air entrainment content and slump testing as required. Cylinders may be required and tested at the expense of the developer. Concrete mix designs must meet PennDOT Publication 408.
- c. Apply curing compound to poured concrete. Curing compound shall be AASHTO M 148 Type 1-D.
- d. Weather protection shall be used in accordance with PennDOT Publication 408.

- e. Belgium Blocks/Granite Blocks to be Jumbo, 10”-11” in height. Reference Upper Dublin Township Belgium Block Curb and Paving Detail, latest version.

12. Sidewalk

- a. Inspection of subgrade, general alignment and any forms to be used. Forms must be straight, undented, free of foreign material and may not discolor concrete. Steel forms are required except as permitted by inspector. String line shall be set and checked by inspector prior to any forming or concrete pour to show line and grade, profile and alignment.
- b. Material inspection, including the submittal of all certified material delivery slips, air entrainment content and slump testing as required. Cylinders may be required and tested at the expense of the developer. Concrete mix designs must meet PennDOT Publication 408.
- c. Inspection of installation and finish shall be in accordance with PennDOT Publication 408.
- d. Sidewalk shall require full-time inspection. Approval of concrete mix to be used with proper additives is required 72 hours prior to pouring.
- e. Penetrating sealer to be immediately applied after finishing operation. Penetrating sealer to be Aquaron CPT 2000 or approved equal.
- f. Weather protection shall be used in accordance with PennDOT Publication 408.
- g. Inspection of subgrade prior to stone placement.
- h. Inspection of subbase grade and form grade and alignment prior to any pour.
- i. Inspection of finish and application of penetrating sealer, means of insulation (cold weather blanketing).

13. Right-of-Way Grading

- a. Inspection of required finish grade elevations to limits of street right-of-way or as required on the approved plans.
- b. All areas within right-of-way shall be graded to be mowable with a riding mower, slope no greater than two (2) percent unless approved by Township Engineer or the Township Engineer’s representative.

14. Seeding, Sodding and Erosion Controls

- a. Inspection as required to insure compliance with approved plans, regulations and general acceptable methods and practice. Site-specific details will be placed on plans to accommodate individual requirements. All requirements of the approved Conservation District plans as well as changes from site inspections by Montgomery County Conservation District (MCCD) will be inspected. In addition to MCCD inspections, periodic inspections will be conducted by the Township or Township Engineer.
- b. Periodic inspection of all erosion and sediment controls will be made by Township or Township Engineer to insure controls are functioning properly and to insure compliance with Township's NPDES Permit.

15. Landscaping

- a. Inspection as required to insure compliance with approved plans, regulations, generally accepted methods and practice.
- b. Verification of type of plant material, total quantity installed, location, proper maintenance of plant materials.
- c. Follow-up inspection to insure proper watering, maintenance and other required care is performed.

16. Utility Trenches

- a. Inspection as required to insure compliance with the approved plans, regulations, generally accepted methods and practice.
- b. Location, depth of trench, screenings, backfilling and compaction of trench.
- c. Full 2A stone backfill, eight (8) inch lifts compacted to 95% AASHTO Dry Density Method is required. Flowable fill may be substituted for 2A stone with the approval of the Township Engineer.
- d. Restoration of High Early strength concrete and/or base, binder and wearing courses.

H. Drafting Standards

1. The scale of the Plan shall not be smaller than one hundred (100) feet to the inch and shall be accurate to within one (1) part in three hundred (300).
2. Dimensions shall be in feet and decimals and bearings in degrees, minutes and seconds.

3. The Plan shall show the courses and distances of the boundary line survey of the entire tract.
4. The sheet or sheets shall be one (1) of the following sizes: 8½ by 11 inches, 11 by 17 inches, 24 by 36 inches or 30 by 42 inches. If more than one (1) sheet is necessary, each sheet shall be the same size and consecutively numbered to show its relation to the total number of sheets comprising the Plan (i.e., Sheet No. 1 of 5). In addition, a digital copy of all materials must be submitted in a .pdf format.
5. Where there are two (2) or more sheets, a Key Map must be provided sufficient to show their relationship.
6. The Plan must be clear and legible and must be so prepared and bear an adequate Legend to indicate clearly which features are existing and which are proposed.
7. The minimum text size must be no less than 0.1 inches in height.

II. STANDARDS OF CONSTRUCTION

The following standards shall supplement the Upper Dublin Township Zoning Ordinance Chapter 255; Subdivision and Land Development Ordinance Chapter 212; Grading and Excavating Ordinance Chapter 99; Stormwater Management Ordinance Chapter 206; and all other ordinances and regulations of Upper Dublin Township which pertain to the improvement construction. All materials and methods of construction are to be in accordance with Upper Dublin Township, Montgomery County Department of Roads and Bridges and PennDOT Standards and Specifications, whichever may be greater. Interpretation shall rest with the Township Engineer or the Township Engineer's representative in the field.

A. Streets

1. General Requirements

- a. The construction of streets in the Township of Upper Dublin shall be done in conformity with the specifications, regulations and provisions set forth in this manual, together with the "Minimum Street Construction Standards" (Table 3) made a part hereof.
- b. In the case of new roads within subdivisions and land developments or any existing roads to be widened, all roads and streets shall be designed and constructed in accordance with the provisions of the Upper Dublin Township Code and these Standards, latest edition.

- c. All work done pursuant to the provisions of these Standards shall be inspected by the Township Engineer or Township Engineer's Representative in the field.
- d. The design of all streets shall be in accordance with the guidelines and requirements for Design of Local Road and Streets contained in PennDOT Design Manual, Part 2, Highway Design, latest revision, the Township Codes, AASHTO, and these Standards.
- e. Lines, grades and location of streets shall be as approved on recorded plans of Subdivision, Land Development Plans, or other plans as may be approved by the Township.
- f. All components of the pavement structure and methods of application shall be in accordance with PennDOT Specifications, Publication 408, latest revision, and the PennDOT Roadway Construction Standards, latest edition.
- g. All adjacent structures and areas disturbed or damaged during street or road construction shall be properly repaired, restored or replaced to the satisfaction of the Township by the party causing said damage.
- h. Clearing and Grubbing - All trees, roots, stumps, brush, downed timber, wood, rubbish and any other objectionable material shall be removed from the site. Disposal of any materials removed shall be in accordance with PADEP Standards. Removal shall include the excavation of any material or obstruction interfering with the proposed road construction to a minimum depth of three (3) feet below subgrade, for the full right-of-way width, or as approved by the Township Engineer.
- i. All new private streets are required to be constructed to residential street standards.
- j. All new streets in commercial, shopping center, office center, employment center and institutional zoning districts are required to be constructed to secondary road standards. Additional depth of paving may be required where trucks, deliveries or weight intensive vehicles are to be encountered.
- k. All widening of existing streets must be constructed in compliance with details RD104-RD107.

2. Design Standards

a. Right-of-Way Width, Paving Width and Curbing

(1) Classification. All streets will be classified as Cul-de-sac, Residential, Secondary, Primary, or Arterial and shall be governed as follows:

(a) Cul-de-sac Streets

(i) The length shall not be more than five hundred (500) feet nor less than two hundred and fifty (250) feet unless special conditions submitted by the applicant warrant approval by the Board of Commissioners. Measurement of cul-de-sac length shall conform to that used for Liquid Fuels by PennDOT.

(ii) For residential cul-de-sac streets, the minimum right-of-way shall be fifty (50) feet, and a minimum cartway width of thirty (30) feet, a circular turnaround with a minimum right-of-way radius of fifty (50) feet and an outer paving radius of forty (40) feet unless a larger paved radius and right-of-way radius is specified by the Township.

(iii) For cul-de-sac streets other than residential, the minimum right-of-way shall be sixty (60) feet, a minimum cartway width of 40', a circular turnaround with a minimum right-of-way radius of sixty (60) feet and an outer paving radius of fifty (50) feet unless a larger paved radius is specified by the Township.

(iv) Construction shall be in accordance with the Standards.

(v) Temporary cul-de-sacs are those cul-de-sacs constructed to an abutting property line with the intention that such road will be extended onto the adjoining property at a future date as a logical step in the circulation network of neighborhood, superblock, or areas. Temporary cul-de-sacs shall be required by the Board when conditions so warrant. Temporary cul-de-sacs shall be designed and constructed with the same design standards as permanent cul-de-sacs.

(vi) Temporary cul-de-sacs shall have an easement for the turnaround area in a form suitable to the Township Solicitor.

(b) Residential Streets

Residential Streets shall be those which are used strictly to serve residential areas and do not serve as through streets in a development. They shall have a minimum right-of-way width of fifty (50) feet and shall have a minimum paved cartway width of thirty (30) feet. Construction shall be in accordance with the Standards.

(c) Secondary Streets

Secondary Streets shall have a minimum right-of-way sixty (60) feet and shall have a minimum paved cartway width of forty (40) feet. Bike lanes, curbing and/or sidewalk shall be provided as required. Construction shall be in accordance with the Standards.

(d) Primary Streets

Primary Streets shall have a minimum right-of-way of eighty (80) feet and shall have a minimum paved cartway width of fifty-two (52) feet. Bike lanes, curbing and/or sidewalk shall be provided as required. Construction shall be in accordance with the Standards.

(e) Arterial Streets

Arterial Streets shall have a minimum right-of-way of one hundred (100) feet, and shall have a minimum paved cartway width of eighty (80) feet. Curbing and/or sidewalk, appropriate median, widening at intersections for turning lane, channelization, center left turn lanes, bike lanes, etc. to be in accordance with the Standards. Construction shall be in accordance with the Standards.

(2) Ultimate Rights-of-Way and Setbacks. Subdivision of lots along existing streets of insufficient width shall affect a widening and dedication of right-of-way to provide a width from the physical centerline to side line of right-of-way of, and shall establish an ultimate right-of-way line which shall correspond with the ultimate right-of-way and cartway widths for these streets as defined in the Township Official Street Map.

(3) Street Classification List

(a) Arterial Streets

- (i) Pennsylvania Avenue
- (ii) *Limekiln Pike
- (iii) Bethlehem Pike
- (iv) Welsh Road
- (v) *Dreshertown Road
- (vi) Butler Pike
- (vii) Morris Road
- (viii) *Ft. Washington Avenue
- (ix) Virginia Drive
- (x) *Susquehanna Road
- (xi) Commerce Drive
- (xii) Route 309 (120' R.O.W.)

(b) Primary Streets

- (i) *Limekiln Pike
- (ii) Jarrettown Road
- (iii) Norristown Road
- (iv) *Ft. Washington Avenue
- (v) *Dreshertown Road
- (vi) *Susquehanna Road
- (vii) **Twining Road
- (viii) Fitzwatertown Road
- (ix) Loch Alsh Avenue
- (x) Lindenwold Terrace
- (xi) Maryland Drive
- (xii) Summit Road
- (xiii) **Camp Hill Road
- (xiv) North Hills Road
- (xv) Jenkintown Road

(c) Secondary Streets

- (i) Stout Road
- (ii) **Twining Road
- (iii) New Jersey Drive
- (iv) Pinetown Road
- (v) Broad Street
- (vi) Bantry Drive
- (vii) Dublin Road
- (viii) Bell Lane
- (ix) Hague's Mill Road
- (x) Argyle Road

- (xi) Ambler Road
- (xii) Randolph Road
- (xiii) **Camp Hill Road
- (xiv) Leah Drive
- (xv) Dillon Road
- (xvi) Woodland Road
- (xvii) Dundee Drive
- (xviii) Jill Road
- (xix) Dale Road
- (xx) Cedar Road

*Refer to Official Street Map to determine Arterial or Primary.

**Refer to Official Street Map to determine Primary or Secondary.

- (4) Additional Width Requirements. Additional widths may be required by the Township in the event of one or more of the following:
 - (a) Where necessary for public safety and convenience.
 - (b) For parking in commercial or industrial areas.
 - (c) Where old roads do not provide the proper width and additional dedication is necessary.
- (5) The area between an existing right-of-way line and the ultimate right-of-way line shall be offered for dedication to the authority having jurisdiction over the road when land is subdivided or developed along an existing right-of-way. Should other governmental agencies not accept dedication, the Township may accept dedication for the public's protection and interest.
- (6) No fences, hedges, trees, shrubbery, walls, signs, plantings or other obstructions shall be located or permitted within the right-of-way except for ground covers such as grass, ivy, crown-vetch, or horizontally spreading shrubs less than (1) foot high, or retaining walls necessitated by road widening and constructed/approved by the authority having jurisdiction over the road. Existing trees to remain within newly dedicated right-of-way shall be certified to be healthy, free of disease and able to withstand impact of road widening by the Township Landscape Consultant.
- (7) The setbacks contemplated in the Zoning Ordinance shall be measured from such ultimate right-of-way line. Where the subdivision or land development is along a State or County highway right-of-way, the setback lines shall be measured from the required right-of-way line or the township ultimate right-of-way line, whichever is at a greater distance.

(8) Islands, Medial Strips, Channelization may be required in any area where traffic volumes warrant their use for safety and efficiency, and may be permitted in any area at the discretion of the Board of Commissioners and Township Engineer.

b. Alignment

(1) Vertical Curves. Vertical curves shall be used at all changes in grade. The length of curve shall be dependent on the sight distance and drainage considerations, and shall be in accordance with “A Policy of Geometric Design of Rural Highways” by the American Association of State Highway Transportation Officials (AASHTO).

(2) Maximum Grades. Maximum grades to be provided shall be seven percent (7%) on arterial, primary and secondary streets; and ten percent (10%) on residential and cul-de-sac streets for distances of not more than fifteen hundred (1500) feet. However, grades in excess of five percent (5%) shall be avoided wherever possible. The grade of the street shall be measured along the centerline.

(3) Minimum grades. There shall be a minimum grade of at least one percent (1%) on all streets.

(4) Horizontal Curves shall be used at all changes in alignment. Long radius curves shall be used rather than a series of curves connected by short tangents. Minimum radius curves at the end of long tangents will not be approved.

(a) Curvature. The minimum radius at the centerline for horizontal curves on Arterial and primary streets shall be three hundred (300) feet; for secondary streets, two hundred (200) feet; and for cul-de-sac and residential streets one hundred fifty (150) feet. Larger radius curves may be required if so warranted.

(b) Except for cul-de-sac and residential streets, the minimum tangent between reverse curves shall be one hundred (100) feet.

(5) Curve-grade Combinations. A combination of minimum radius horizontal curves and maximum grades will not be approved.

c. Intersections

(1) Number of Intersections. No more than two (2) streets shall cross at the same point. When existing streets intersect at odd angles, or have more than four (4) approaches, the subdivider, developer or builder shall be required to make corrective changes to eliminate the odd angle

or reduce the number of approaches to the intersection by curving the lesser street.

- (2) **Minimum Angle of Intersection.** Right angle, ninety degree (90°) intersections shall be used whenever practicable, especially when residential and cul-de-sac streets empty into secondary streets; there shall be no acute intersection angle, measured at the centerline, of less than seventy five degrees (75°).
- (3) **Centerline.** Where centerlines of cul-de-sac, residential or secondary streets open into opposite sides of an arterial and primary street within two hundred 200 feet of each other, they shall be made to coincide by curving the lesser classification street or streets.
- (4) **Primary Thoroughfare.** Wherever practicable, intersections with Arterial, secondary or primary highways, opposite each other or on the same side, shall be kept to a minimum and shall be located at least eight hundred (800) feet apart.
- (5) **Sight Distance.** Sight distances at intersections and driveways entering all streets shall be established in accordance with PennDOT Design Standards for posted speed limits of the streets involved per Chapter 441. No buildings, trees, hedges, shrubbery or other obstruction whatsoever will be permitted in this area. Any obstruction to sight shall be removed at the time a building or structure is erected whichever shall first occur. A note shall be provided on the approved plans requiring developer/property owner to maintain the sight distance standard.
- (6) **Clear sight triangles** shall be provided in accord with Table 2 and measured along the street/driveway centerline. No building, trees, hedges, shrubbery or other obstruction whatsoever will be permitted in this area. Any obstruction to sight shall be removed at the time a building or structure is erected whichever shall first occur. A note shall be provided on the approved plans requiring developer/property owner to maintain the sight distance area free from obstructions.
- (7) **Approach Grades.** All approaches to an intersection shall not exceed four percent (4%) for a distance of one hundred (100) feet measured from the nearest right-of-way line of the intersecting street, along the centerline of the street.
- (8) **Radii of Pavement and Right-of-Way at Intersections.** Street intersections shall be rounded with tangential arcs at pavement edge (curb line) and right-of-way lines as listed in Table 2 below. Where two streets of different right-of-way widths intersect, the radii of curvature for the greater classification street shall apply.

TABLE 2: DESIGN DISTANCES FOR VARIOUS STREETS

Type of Street	Minimum Radius of Arc at Intersection of Pavement Edge or Curb Line (feet)	Minimum Radius of Arc at Intersection of Right-of-Way Line (feet)	Clear Sight Triangle for Obstructions (feet)
Arterial/Primary	40	30	125
Secondary	35	25	100
Residential	25	15	75

All street paving must conform to the Standards of Upper Dublin Township, Montgomery County Department of Roads and Bridges or PennDOT and be approved by the Township Engineer prior to acceptance by the Board. All grades, horizontal curves, vertical curves, and sight distance requirements of this ordinance shall be subject to the approval of the Township Engineer.

3. Construction Standards

a. Subgrade

- (1) Subgrade shall be prepared to accommodate the placement of the pavement structure and shoulders or gutters in accordance with PennDOT Publication 408, Section 210, subgrade, current edition, and within reasonably close conformity to the lines, grades and widths shown on the drawings and cross-sections or as otherwise directed.
- (2) Subgrade shall be graded to the elevation and cross-section required with suitable soil or granular material, compacted to the required density.
- (3) In cases where the required density or stability cannot be obtained, the material in the area shall be excavated to a depth that when replaced and re-compacted at a moisture content not exceeding optimum, the subgrade will have the required stability. The use of PennDOT approved Class 4 geotextile fabric shall be required as directed in the field by the Township Engineer or the Township Engineer's representative in the field. Subgrade conditions shall warrant the type of fabric required. Alternate designs must be prepared by a Registered Engineer competent in Soils Engineering and approved by the Township Engineer.

- (4) The subgrade shall be properly prepared to receive the subbase. Subgrade areas must be approved the morning of the day stone subbase or stone base course is to be placed.
- (5) Where the surface of an existing paved roadway conforms approximately to the proposed subgrade elevation, or where an embankment less than nine (9) inches in depth is to be made over such roadway, the surface of the old roadway shall be milled full depth and reshaped to proper subgrade elevation or excavated and removed.
- (6) Subgrade Stability Verification

After contractor has prepared subgrade in accordance with PennDOT 408, Section 210, Subgrade, current edition, a Subgrade Stability Verification is required prior to placement of subbase material. A triaxle fully loaded maximum load (quarry slip of loaded weight will be required in the field) is required to run over entire roadway subgrade (including curb lines), over all trenches and anywhere directed by Township Engineer or the Township Engineer's representative in the field. Areas displaying pronounced elasticity, pumping, movement or deformation under the loaded triaxle will be noted and marked in the field. The areas noted and/or marked showing unstable subgrade must be corrected and re-verified for required stability prior to starting subbase construction. All areas that are to be filled, stoned, paved and/or curbed are to be proofrolled by this method. A subgrade stability re-verification is required after any/all rain events, snow events (once cleared and/or melted), introduction of moisture to the subgrade or sub-base, or as determined by the Township Engineer or the Township Engineer's representative in the field.

b. Subbase

- (1) This work shall consist of constructing a layer or layers of aggregate on a prepared area in accordance with PennDOT Publication 408, Section 350, Subbase, current edition. Aggregate shall be from an approved supplier listed in PennDOT, Publication 34, Bulletin 14, current edition.
- (2) The aggregate shall be stone, meeting the requirements of PennDOT Type C or better, 2A material, or approved equal. No red "argillite" material will be allowed.
- (3) If at the time of construction, local unstable subgrade conditions are encountered, the Township Engineer or Township Engineer's Representative may require that all areas of unstable subgrade be excavated to sufficient depth, replaced with approved material and

compacted to a density and stability equal to or greater than the surrounding subgrade, and/or require the use of a PennDOT approved Class 4 Geotextile fabric, per Publication 408, Section 212, current edition. Any areas so replaced will be re-proofrolled. Obtain geotextile material from a producer listed in PennDOT Publication 35, Bulletin 15, Approved Construction Materials, current edition.

- (4) Subbase must be approved on morning of the day the base paving is proposed, prior to blacktop release from plant.

c. Base Course

- (1) Base courses shall consist of one or more layers of materials conforming to the requirements of one or more of the following sections of PennDOT Publication 408, current edition:
 - (a) Section 309 – Superpave Asphalt Mixture Design, Standard Construction, HMA Base Course.
 - (b) Section 409 – Superpave Mixture Design, Standard and RPS Construction of Plant-Mixed HMA Courses.
 - (c) Section 501 – Reinforced or Plain Cement Concrete Pavements.
- (2) Notwithstanding any provision of these specifications, a special base course design may be approved by the Township Engineer, providing the design provides a structural number and frost protection equal to or greater than the number for the appropriate base course listed in the attached Minimum Street Construction Standards (Table 3).
- (3) Special complete roadway design may also be submitted for approval by the Township, Board of Commissioners and the Township Engineer, provided the design provides a structural number and frost protection equal to or greater than the number in the Minimum Street Construction Standards (Table 3).
- (4) Base course(s) will be placed in layers as is more fully described in Publication 408, current edition, for each specific design, or as may be specified otherwise by the Township.
- (5) All subbase(s) shall be properly prepared and primed as may be required for base course placement according to Publication 408, current edition.
- (6) Base course(s) shall be properly prepared and primed as may be required to receive subsequent courses.

- (7) No red argillite material will be allowed.

d. Bituminous Pavements

- (1) Bituminous pavements shall consist of one or more courses of bituminous mixture constructed on the prepared foundation in accordance with Publication 408, Section 409, Superpave Mixture Design, Standard and RPS construction of plant-mixed HMA courses, current edition, and the specific requirements of the type of pavement as may be approved by the Township and the Township Engineer.
- (2) Bituminous mixtures shall be from an approved supplier listed in PennDOT Publication 41, Bulletin 41, Producers of Bituminous Mixtures, current edition.
- (3) All paving courses shall be compacted by use of approved type power rollers, per PennDOT Publication 408, current edition, having a metal weight of not less than ten (10) tons. Locations not accessible to rollers shall be compacted by hot iron tampers or other compaction equipment approved by the Township Engineer.
- (4) Prior to application of additional bituminous courses, existing base courses shall be inspected by the Township representative for defects such as fracture, cracking, or other signs of base failure, or potential failure. All areas of failure, or potential failure, shall be removed by saw cutting, milling machine, pneumatic hammer (corner areas only) and replaced, or repaired, to the satisfaction of the Township representative.
- (5) Prior to application of any bituminous paving courses, paint all vertical surfaces of curbs, inlets, manholes, gutters and other structures to come in contact with bituminous mixtures with a uniform coating of bituminous material per PennDOT Publication 408, Section 401.3(g).1., current edition.
- (6) Prior to application of any bituminous binder or wearing courses, install tack coat per PennDOT Publication 408, Section 460, current edition.
- (7) Joints formed by binder or surface course laid adjacent to concrete curbs, inlets, utility cover or other rigid structures and trench repair areas shall be sealed with rubberized joint sealing material Type 4 (c) or approved equal to a twelve (12) inch width as directed by the Township Engineer or the Township Engineer's representative in the field. Obtain material from a producer listed in Bulletin 15. Joints

shall be cut by use of a saw or milling machine, pneumatic hammers to be used in corner areas only.

4. All new roads within Upper Dublin Township must be constructed in accordance with Table 3.

TABLE 3 – MINIMUM STREET CONSTRUCTION STANDARDS

ROAD CLASSIFICATION	CUL-DE-SAC/ RESIDENTIAL	SECONDARY	PRIMARY	ARTERIAL
Superpave asphalt mixture design, HMA wearing course, PG 64-22. 9.5mm mix, SRL H	1 ½”	1 ½”	1 ½”	1 ½”
Superpave asphalt mixture design, HMA binder course, PG 64-22. 19.0mm mix	2”	2”	2”	2”
Superpave asphalt mixture design, HMA base course, PG 64-22. 25.0mm mix	3”	4”	6”	8”
2A stone	6”	6”	6”	6”
Sidewalk	Required	Required	Required	Required
Minimum Structural Number	3.4	3.5	4.6	5.5
Esal Rating	0.0 to 0.3 million Esals	0.3 to 3.0 million Esals	0.3 to 3.0 million Esals	3.0 to 30.0 million Esals

Notes:

- (1) All thickness specifications are for properly compacted materials in place.
- (2) Alternate design cross-sections when permitted, may be approved by the Township provided the design has a Structural Number equal to or greater than that shown in the above chart and field weather conditions permit.
- (3) Permanent Cul-de-Sac Street, Marginal Access Street, Private Street, Common Driveway and Service Street construction shall conform to standards for Residential Streets.
- (4) Binder course to be installed immediately following base course installation.
- (5) Standards for roads owned by the Commonwealth of Pennsylvania (PennDOT) and the County of Montgomery may differ from those shown.

B. Curb and Sidewalk

1. Cement Concrete Curb

- a. Extruded curb (Machine Slip Form) shall have a minimum structure height of eighteen (18) inches with an eight (8) inch reveal (except as noted in section e, below), installed on a minimum layer of four (4) inches of AASHTO #57 stone or PennDOT 2B clean stone. Expansion joint ($\frac{3}{4}$ " material shall be placed every forty (40) feet; to full depth of curb, at structures, and at the end of a day's work. Contraction joints shall be saw cut every ten (10) feet a minimum of two (2) inches in depth. Machine Slip Form Curb shall have a minimum 3,750 psi compressive strength (PennDOT Class AA). All depressions require two #5 rebars (per concrete curb detail).
 - b. Formed curb (Panel formed) shall have a minimum structure height of eighteen (18) inches with an eight (8) inch reveal (except as noted in section e, below), installed on a minimum layer of four (4) of AASHTO #57 stone or PennDOT 2B clean stone. Place the concrete in the forms in layers not exceeding five (5) inches in depth when spading, or layers not exceeding fifteen (15) inches in depth when using a vibrator to eliminate voids. Three-quarter ($\frac{3}{4}$) inch expansion material joint shall be every thirty (30) feet, at structures, and at the end of a day's work. Formed Curb shall have a minimum 3,750 psi compressive strength (PennDOT Class AA). Clean steel forms, adequately braced, are to be used.
 - c. Concrete sampling shall be slump tested and cylinders obtained per ASTM C172, C143, C-31.
 - d. Curb shall be dowel pinned into inlets. Two (2) #8 x 1' – 0" Dowell bars on both sides of inlet.
 - e. Curbs within non-dedicated roads or parking areas may have a six (6") inch reveal, if approved by the Township Engineer.
2. Belgian block, granite or other stone curb may be substituted, on non-dedicated streets, with written approval of the Township Engineer, provided adequate drainage and safety are maintained.

3. Cement Concrete Sidewalk

- a. Cement Concrete Sidewalk shall be a minimum of five (5) feet wide, four (4) inches thick, placed on a minimum four (4) inch layer of AASHTO #57 or 2 B clean stone bedding or if in a State right-of-way, a minimum six (6) inch layer of AASHTO #57 or 2B clean stone bedding. Expansion joints

shall be every thirty (30) feet, with transverse control joints cut or formed every five (5) feet, one-eighth inch (1/8") wide and one (1") inch in depth. Additional expansion materials shall be placed between any curb and driveway aprons and in the sidewalk at the driveway limits. All sidewalks shall receive a broom finish unless approved otherwise by the Township. Provide a minimum 3,750 psi compressive strength concrete, (PennDOT Class AA).

- b. Curb ramps shall be constructed in accordance with the Township Sidewalk Standards, PennDOT Standards and ADA Standards unless so directed by the Township or PennDOT. Provide "Cast-in-place Truncated Dome Detectable Warning System" as manufactured by ADA Solutions Inc. or approved equal. Color: Brick Red.
- c. The maximum sidewalk slope is eight (8%) percent.

4. Cement Concrete Driveway Apron

- a. Driveway aprons, within residential areas, shall be at least six (6) inches thick with a welded wire fabric WWF 6 x 6 – W1.4 x W1.4 (2" from the top surface of the concrete), placed on a minimum six (6) inch layer of AASHTO #57 or 2B clean stone bedding. All Cement Concrete Driveway Aprons shall receive a broom finish unless approved otherwise by the Township. Minimum concrete compressive strength is 3,750 psi (PennDOT Class AA). For non-residential areas, thickness of concrete and stone shall be increased to suit the vehicle loading anticipated and in no case shall it be less than required by CC202.
- b. A depressed curb for residential driveway entrances is permitted rather than a horizontal radius. The curb shall be depressed by rounding the edge from the top of the curb to the gutter line. The bottom line of the curb shall be maintained. The sloped portion of the driveway on all new construction shall terminate at the closest edge of sidewalk and at the gutter line. A lip of one and a half (1½") inches in height shall be constructed at the gutter line, with a one (1) inch rise to the back of curb. Two (2) #5 deformed bars shall be provided for reinforcement.
- c. Provide control joints and expansion joints per the Township Details.

5. Penetrating Sealer

All concrete to be sealed with a Penetrating Sealer, Aquaron CPT 2000 or approved equal, immediately after final finish of freshly poured concrete.

6. Concrete

- a. All concrete must be in accordance with PennDOT, Publication 408 current edition. Concrete Supplier must be PennDOT certified or plant/supplier pre-approved by Township.
- b. Construction during cold weather - If the air temperature falls to forty degrees Fahrenheit (40°F) prior to or during any portion of the pour, the following additional conditions apply:
 - (1) Do not start or resume pour until the air temperature rises above forty degrees Fahrenheit (40°F).
 - (2) Concrete cannot be poured on frozen base, subbase or subgrade, including frost in the stone subgrade.
 - (3) Concrete and forms must be covered with polyethylene and insulated with either a one (1) foot thickness of straw and a second layer of polyethylene or a two (2) inch thick insulation blanket to maintain a temperature of not less than forty degrees Fahrenheit (40°F) for seven (7) days.
 - (4) Should a combination of air temperature, frozen subgrade, wind, humidity and anticipated weather conditions dictate, the inspector may terminate or delay pouring until favorable conditions are present.

C. Storm Drainage Pipe Materials

1. All storm drainage pipes up to and including, forty-eight (48) inches in equivalent diameter shall be constructed of one (1) of the following materials:
 - a. Reinforced concrete, rubber gasket conforming to AASHTO M170, M198 and M207.
 - b. Reinforced concrete, tongue and groove conforming to AASHTO M170 and M207.
 - c. Where permitted High Density Polyethylene (HDPE) smooth bore interior only conforming to ASTM D1248, ASTM D2412, AASHTO M252, and 294, with approval of Township Engineer. Pipe joints shall be Bell and Spigot with a gasket. Gasket shall be polyisoprene meeting the requirements of ASTM F-477. All HDPE pipe shall be placed on a minimum of six (6) inches of AASHTO #57 stone and backfilled with same to a minimum of one (1) foot above the crown or top of the pipe for diameters up to 48" and two (2) feet for diameters 48" and above. Any

pipe within rights-of-way or with less than two (2) feet of cover requires full stone backfill, properly compacted.

- d. High-density polyethylene (HDPE) perforated underdrain shall conform to AASHTO M252.
2. All storm drainage pipe and/or culverts above forty-eight (48) inches in equivalent diameter shall be constructed of one (1) of the following material:
 - a. Reinforced concrete tongue and groove conforming to AASHTO M170 and M207.
 - b. Reinforced concrete piping, rubber gasket, shall conform to AASHTO M170, M198 and M207.
 - c. Precast reinforced concrete box sections in accordance with AASHTO M259.
 - d. Reinforced cement concrete cast-in-place; mix design strength of 3,750 psi or better.
3. General
 - a. All pipe and/or culverts (cross drains) inflow and outflow ends shall have reinforced concrete pre-cast or cast-in-place full flow inverts to limits of required endwall sections, with invert base end cutoff walls extending three (3) feet below channel flow line, or to rock, whichever occurs first.
 - b. All culverts with equivalent diameter greater than twenty-four (24) inches or culverts with a slope of greater than five percent (5%) behind the structure shall have Type "DW" headwalls/endwalls installed; others shall have Type "D" walls.
 - c. Installation having a maximum five (5) foot vertical rise from flow channel invert to crown of street, with the required maximum 3 to 1 embankment slope from limit of right-of-way to elevation of flow channel invert, shall not require protective parapets. All other installations shall require protective concrete parapets and approach guide rail in accordance with PennDOT Standards.
 - d. All culvert structures other than pipes, shall require submission of complete design drawings and shop drawings, for review and approval by the Upper Dublin Township Engineer, to insure compliance with HS-25 live loading, flow design capacity and calculated life cycle of proposed structures.

- e. All storm sewer piping shall have a minimum of two (2) feet of cover from outside of pipe bell to finished grade. In the case of a storm sewer connection to an existing facility, where it is impossible to achieve two (2) feet of cover, this requirement may be reduced with the written approval of the Township Engineer.
- f. Provide 6 (six) foot inlets at all low points, or as directed by Township Engineer.
- g. All storm drainage design must be in conformance with Stormwater Management Ordinance, Chapter 206.

4. Bridge

- a. An enclosed water carrying structure of one or more barrels or cells having a combined span of eight (8) feet or greater is considered a bridge.
- b. All bridge designs shall be in accordance with PennDOT Design Manual, Part IV (latest revisions) and shall be submitted to the Upper Dublin Township Engineer for approval of materials, structural design, to insure compliance with HS-25 live loading, flow design capacity and calculated life cycle of proposed structures. All bridges shall have approach guide rail and parapets in accordance with PennDOT Bridge Design and Constructions Standards.

D. Storm Drainage Appurtenances

Headwalls, endwalls, inlets, manholes and energy flow dissipators shall be in accordance with PennDOT Publication 408, Latest Edition. Channels (poured inverts) shall be poured in inlets and manholes using 4,000 psi compressive strength concrete (see Construction Details). All precast structures must be certified - stamped by PennDOT at plant if required by Township.

E. Materials for Trench Backfill

- 1. All trenches require full 2A stone backfill mechanically tamped in eight (8) inch lifts to a density of ninety-five (95) percent of modified proctor density (ASTM D-1557). If approved by the Township Engineer or the Township Engineer's representative in the field, select backfill may be used.
- 2. Trenches within existing and new roadways must, without exception, be backfilled with full depth 2A stone.

3. Refer to Township Trench Details for pipe bedding and additional requirements.

F. Storm Drainage Detention/Retention Basins

1. General

Detention or retention basins for the control of storm water discharge shall meet the following requirements:

- a. Basins shall be installed prior to any earthmoving or land disturbances, which they will serve. The phasing of their construction shall be noted in the narrative and on the plan of erosion control.
- b. Whenever a basin will be located in an area underlain by limestone, a geological evaluation of the proposed location will be conducted to determine susceptibility to sinkhole formations. The design of all facilities over limestone formations shall include measures to prevent ground water contamination and, where necessary, sinkhole formation. Soils used for the construction basins shall have low-erodibility factors ("K" factors).
- c. Energy dissipators shall be installed at points where pipes or drainageways discharge to or from basins.
- d. Concrete, stone or gabion low flow channels shall be utilized when required by the Township Engineer
- e. Discharge point of basins shall be to a defined waterway or stream.
- f. An as-built of the detention basin shall be required prior to the placement of topsoil to verify adequate storage has been provided and the spillway and berm height are per plan.

2. Primary Outlet Structures & Pipe

- a. Pipe - Reinforced concrete, rubber gasketed "O-ring", shall conform to AASHTO M170, M198 and M207.
- b. Poured-in-Place Outlet Structure - Reinforced concrete, minimum 4,000 psi compressive strength in accordance with PennDOT Publication 408, Latest Edition. Submit design for Township review and approval.
- c. Precast Outlet Structure - Reinforced concrete, minimum 4,000 psi compressive strength in accordance with PennDOT Publication 408, Latest Edition. Submit design for Township review and approval.

- d. Precast Reinforced Concrete Box Sections in accordance with AASHTO M259.
- e. Orifice Plates - Stainless steel, type 304, with stainless steel mounting hardware. Use $\frac{3}{8}$ inch thick plate steel. Burnish a smooth edge on all surfaces.
- f. Headwalls/Endwalls - Reinforced concrete, minimum 4,000 psi. Compressive strength in accordance with PennDOT Publication 408, Latest Edition. Splash pads are required for all headwalls and endwalls.
- g. Cutoff (Anti-Seep) Collars - Reinforced concrete, minimum 4,000 psi compressive strength. A minimum of two (2) required.
- h. Concrete Pipe End Sections - Reinforced concrete in accordance with PennDOT Publication 408.
- i. Steel Grates - In accordance with PennDOT Publication 408, Latest Edition. Grates shall be bicycle safe, unless otherwise noted.

3. Emergency Spillway Structure

- a. On Fill - Gabion mattresses minimum nine (9) inches thick or equivalent, all placed on geotextile fabric Class 4. Gabion materials shall be in accordance with PennDOT Publication 408. Installation shall be in accordance with manufacturer's recommendations. Other types of spillway construction may be approved by Township Engineer.
- b. On Natural Ground – Methods and materials to be approved by the Township Engineer.
- c. Emergency spillway location shall not coincide or be built over top of outlet pipe or structure.

4. Embankment

- a. Embankment Structure - Materials suitable, type CL or ML soils (clay soil) including an impervious core and cutoff trench shall be placed to limit the seepage through the embankment so that no internal erosion takes place.
- b. Exterior slopes of compacted soil shall not exceed one (1) foot vertical for three (3) feet horizontal if ground cover not requiring mowing is utilized, and shall be one (1) foot vertical for four (4) feet horizontal when

vegetation requiring mowing is utilized. The slopes may be further reduced if the soil has unstable characteristics. Compaction testing is required to provide 95% to 98% dry density per AASHTO Dry Density Method.

- c. Interior slopes of the basin shall not exceed one (1) foot vertical in three (3) feet horizontal. Exceptions with approval of the Township are as follows:
 - (1) Where maximum water depth will not exceed three (3) feet; or
 - (2) When a two (2) inch rainfall in one (1) hour will not fill the basin in one (1) hour; or
 - (3) Where concrete, stone or brick walls are used with side slopes proposed to be steeper than one (1) foot vertical in three (3) feet horizontal, in which case the basin shall be fenced with a permanent non corrosive chain link wire fence or other material as approved by the Township. The fence shall be forty-eight (48) inches in height and a ramp of durable, non-slip materials for maintenance vehicles shall be provided for access into the basin.

G. Underground Detention/Groundwater Recharge

- 1. Structure – Material must be RCP or HDPE, as approved by Township Engineer. Submit design for Township Engineer review and approval.
- 2. Location – Location of groundwater recharge basins must be supported by percolation testing using double ring infiltrometer to verify suitability and design percolation rates.

H. Geotextiles

- 1. Geotextile Materials shall be used for but not limited to the following uses:
 - a. Class 1 - Subsurface drainage.
 - b. Class 2 - Erosion Control.
 - c. Class 3 - Sedimentation Control.
 - d. Class 4 - Layer separation, stabilization, reinforcement.

2. During any project review phase, construction phase, and inspection phase, the Township of Upper Dublin and/or the Township Engineer can require the use of Geotextile Fabrics for any of the above noted Classes.
3. Geotextile fabric placement, securing, pin spacing, and physical property requirements shall meet the standards of PennDOT Publication 408, current edition.

I. Signs and Markings

1. Street Signs

- a. Street signposts, hot dipped galvanized steel (or aluminum tubing, twelve (12) foot one-piece section, 2 3/8" O.D.) minimum two (2) pounds per foot. Breakaway fittings are required at the sign base per PennDOT Publication 408, Latest Edition.
- b. All fittings shall be aluminum and/or stainless steel, consistent with sign post material.
- c. Signs shall be extruded aluminum minimum .080 gauge thickness.
- d. Sign facing shall be 3M Engineer Grade, color white.
- e. Letters shall be 3M Series 605-B.H.A., color black reflective, 6 inches in height.

2. End of Street Permanent Barricade

- a. Barriers shall be pressure treated lumber, full depth to 0.60 PCF (pounds per cubic foot), in accordance with PennDOT Publication 408, Latest Edition.
- b. Barrier structure shall be post and beam type construction, 6" x 8" posts installed thirty-six (36) inches below finish grade, by mechanical driving or setting in concrete. The post spacing may vary to a maximum of ten (10) feet center to center. Three 2" x 10" cross members shall be bolted to the framing structure as self-supporting.
- c. Barrier length shall be full width of cartway, barrier height shall be sixty (60) inches, as measured from adjacent street surface.
- d. Barrier shall have PennDOT Class I or Class I-A or Class II reflective sheeting applied to the aluminum blank and fastened to wood planks on barrier facing direction of traffic approach.

e. Barriers shall be notched at the base to breakaway in the event of impact.

3. End of Lane Markings

All streets and/or widened sections of roadways where the widened portion or lane ends shall be provided with right clearance markers PennDOT W16-2-2R, painted lines and painted “gore” areas. The marker shall be 12" x 36" with reflectorized white and red strips. The bottom of the marker shall be at a height of four (4) feet above the pavement and shall be mounted on a breakaway type steel channel post. Line painting and gore shall be as shown on the approved plan

J. Township Road Access by Driveways and Parking Areas

1. Driveways and Parking Areas

- a. Any and all driveways constructed within Township right-of-way or connecting to a Township right-of-way shall be paved at a minimum from the edge of the existing paved cartway to the ultimate right-of-way line or a minimum of twenty-five (25) feet, as may be determined by the Township. The length of paving may be required to be extended at the request of the Township depending on driveway lengths, slopes and areas of drainage problems and site conditions.
- b. The specifications for bituminous non-residential and multi-family residential driveways shall consist of 1½" depth superpave asphalt mixture design, HMA wearing course, PG 64-22, 0.0 to 0.3 million ESALs, 9.5mm MIX SRL H; two (2) inch depth superpave asphalt mixture design, HMA binder course, PG 64-22, 0.0 to 0.3 million ESALs, 19.0mm MIX; three (3) inch depth superpave asphalt mixture design, HMA base course, PG-64-22, 0.0 to 0.3 million ESALs, 25.0 mm mix and six (6) inches 2A stone. The edge between the driveway and street cartway as well as all curblines, utility boxes, inlets, etc. within the paving shall be sealed with rubberized joint sealing material type 4(C) as manufactured by Crafcoc, Inc. or approved equal.
- c. Residential driveways shall consist of 1½" depth superpave asphalt mixture design, HMA wearing course, PG 64-22, 0.0 to 0.3 million ESALs, 9.5mm MIX SRL H; two (2) inch depth superpave asphalt mixture design, HMA binder course, PG 64-22, 0.0 to 0.3 million ESALs, 19.0mm MIX and eight (8) inch 2A stone. The Township may require a greater depth of wearing course if the wearing course is not installed immediately after binder course.

- d. The Township, upon field inspection, shall determine whether a pipe shall be used under the drive for the purpose of conveyance of shoulder swales. When required, the pipe design capacity shall be determined by drainage computations using a ten (10) year storm frequency. The minimum pipe size shall be eighteen (18) inches unless approved otherwise. The pipe shall be located at least six (6) feet from the edge of cartway unless field conditions, upon Township inspection, indicate modification of these criteria. The minimum length of pipe shall be twenty (20) feet or extend at least two (2) feet minimum on each end beyond the edges of the driveway pavement. Flared end sections shall be required on each end or other methods of outlet and inlet protection may be approved by the Township. When swales are used the gutter shall be at least twelve (12) inches lower than the edge of cartway and six (6) feet from the edge of cartway. This criteria may be modified by the Township should field conditions dictate.
- e. A maximum slope on any driveway shall be ten percent (10%). A leveling area of fifteen (15) feet at a slope no greater than eight percent (8%) shall be provided for every entrance to a road and entrance to a garage.

2. Streets and Driveway Intersections

- a. The general design criteria for the access of all driveways and new streets to a Township road with respect to locations, sight distances, angle of approach, maintenance, restoration of damaged areas and general conditions shall be in conformance with PennDOT Title 67, Chapter 441 Access to and Occupancy of Highways by Driveways and Local Roads and the AASHTO Design Manual, current edition.
- b. The general design criteria for the occupancy of all streets by utilities shall conform to PennDOT Title 67, Chapter 459.

3. Driveway

- a. All driveways for single family residences must be a minimum of ten (10) feet wide. All driveways for multiple residences must be a minimum of twelve (12) feet wide. These multi-family driveways must be at a width approved by the Township Engineer and Township Fire Marshal. Multi-family driveways serve more than one residence.
- b. All driveways, turnaround and paved areas must be setback a minimum of five (5) feet from all property lines.
- c. In the event of a subdivision or road improvement in the area of an existing unpaved driveway, the unpaved driveway must be paved for a distance of 20' behind the sidewalk (or curb if sidewalk is not existing or required).

4. Parking Area

- a. All parking areas must be constructed in accordance with RD105, Multi-Family Residential and Non-Residential Driveway and Parking Detail.
- K. Lighting – Reference standards and details in Section III, Construction Details of these standards and in Upper Dublin Township Ordinance No. 158, latest edition and LS502 and LS503.
- L. Sanitary Sewer – Reference standards and details as provided by Bucks County Water and Sewer Authority.
- M. Traffic Signals

1. General Specifications

- a. All work and all materials shall be in accordance with these specifications and in accordance with the Pennsylvania Department of Transportation “Specifications Publication 408”, latest revision, hereinafter referred to as Publication 408.
- b. The latest edition of the following publications shall apply to all work and all materials performed on this project: PennDOT Publication 72M, “Standards for Roadway Construction – Series RC-0 to 100”; PennDOT Publication 148, “Traffic Standards-Signals TC-7800 Series”; PennDOT Publication 236, “Handbook of Approved Signs”; and PennDOT Publication 111, “Traffic-Control Signing Standards TC-7700 Series”. PennDOT Publication 203 “Work Zone Traffic Control” and PennDOT Publication 408 Specifications.
- c. The Contractor shall be pre-qualified by the Pennsylvania Department of Transportation for the construction and installation of traffic signals. The Contractor shall furnish all materials and workmanship, and all miscellaneous materials, equipment and labor as may be required to complete the traffic signal installation in accordance with the PennDOT approved traffic signal permit.
- d. The Contractor must comply with the PA Utility Act 187 regarding utility company notification and field location verification.
- e. Unless approved in writing from the Township, no exceptions to the requirements of the specifications will be allowed.
- f. All traffic signal equipment and material provided by the Contractor shall be guaranteed for the period of one (1) year following the acceptance of

the project by Upper Dublin Township. The Contractor's workmanship shall be similarly guaranteed.

It is understood that one (1) year's warranty on equipment and installation are to be provided in the following manner:

- (1) The Contractor installing the equipment is responsible for the overall satisfactory operation of the installation for a period of one (1) year dating from the date of acceptance of the signal installation by Upper Dublin Township. The Contractor shall therefore provide service for all malfunctions and assume responsibility for assuring that repairs to equipment are processed through the supplier in an expeditious manner. The Contractor also is responsible with the supplier for providing suitable temporary replacement equipment to maintain signal operation if essential equipment must be removed for servicing.

It is the contractor's responsibility to secure all warranties and guarantees that are customarily issued by the equipment manufacturers. The warranties and guarantees delivered by the manufacturer to the Contractor shall include the provision that they are subject to transfer to the Township and shall be accompanied by proper validation that this is so.

- (2) The supplier of equipment is jointly responsible with the Contractor for servicing equipment malfunctions for a period of one (1) year from the date of acceptance of the signal installation by the Township. Such servicing includes responsibility for checking in the field to determine if malfunctions are due to installation or equipment failures, for supplying suitable temporary replacement equipment or parts to maintain operation and for insuring the warranty repairs to equipment are accomplished in an expeditious manner.
- (3) The Contractor is to conform to all applicable portions of Publication 408 for acceptance testing procedures.

- g. Bidders shall submit catalog information with bid documents for any materials that have a provisional certificate of approval with PennDOT. The successful bidder will be required to submit catalog cuts and/or shop drawings on all materials for approval by the Township. The bidder shall supply the manufacturer's name and model number and PennDOT certificate of approval number for signal equipment on the appropriate form of the proposal.

- h. The Contractor shall review the project site prior to initiating work and shall meet with the representatives of all affected utility companies to determine types and locations of utility facilities. The Contractor shall also field locate the position of the traffic signal supports, controller cabinets and loop detectors in the presence of the Engineer and a representative of the Pennsylvania Department of Transportation prior to any excavation.
- i. As-built documentation of work shall be provided by the Contractor as indicated below prior to acceptance of the work. All documentation shall satisfy the documentation size requirements set forth below:
 - (1) Standard bound materials – 8-1/2” x 11” including 11”x17” fold-out drawings.
 - (2) Non-standard documentation – Mylar reproducible no larger than 24”x36”.
 - (3) All as-built documentation shall be subject to the approval of the Township prior to acceptance.
- j. Maintenance and Protection of Traffic During Construction
 - (1) Revise PennDOT Publication 408, Section 901.3(a) by adding as follows:

Signing will be installed as indicated in Publication 213. Signing for any work done must be coordinated concurrently throughout the work zone. Maintenance and Protection of Traffic during construction will be in accordance with applicable Figs. 5, 7, 10a, 10b, & 16 in PennDOT Publication 213, "Work Zone Traffic Control Guidelines", January 2006, or most current.
 - (2) Keep all traffic lanes open between the hours of 7:00 AM to 9:00 AM and 4:00 PM to 6:00 PM. Do not restrict traffic between these hours.
 - (3) Access to all properties including driveways and walkways must be maintained at all times.
 - (4) Pedestrian and vehicular traffic must be maintained and protected throughout the duration of this project. The Contractor will be responsible for furnishing and using protective barriers at the sites of installation if and when requested by Upper Dublin Township and the Engineer.

- (5) Do not perform any construction during the hours of darkness without written approval from the Township. Upon completion of each day's work, restore all trenched pavement areas by either backfilling or using steel plates. Vehicular and pedestrian traffic must be restored at the close of each work day.
- (6) Do not allow parking of personal vehicles or construction equipment on any traveled roadway, shoulder or seeded areas along the roadways.
- (7) Coordinate delivery of materials for the project so as to minimize the inconvenience to the traveling public.
- (8) Provide access for emergency vehicles at all times.
- (9) Insure warning vests, shirts or jackets (orange) are worn by all employees. Effective November 24, 2008, as specified in regulation ANSI 107-2004, all workers will be required to wear Class 2 high visibility safety apparel. When working at night, provide that the warning vests are reflectorized.
- (10) Maintain constant surveillance of the traffic control operation and replace or correct any missing, damaged, ineffective or misaligned equipment to the satisfaction of the Engineer.
- (11) At all locations within the project limits where existing official traffic signs and devices are removed or relocated, jointly survey and record all official signs and devices by standard number, description, size and location before operations begin.
- (12) Carefully remove and set aside all existing official traffic signs and devices as needed to perform required operations. Do not scratch or damage reflective sheeting face. Allow any vital traffic signs as determined by the Engineer to remain, although they may be placed on temporary supports on an interim basis. Replace all signs or posts damaged during removal or replacement in kind at no expense to Upper Dublin Township.
- (13) The Contractor must coordinate the work with Upper Dublin Township so that the maintenance of traffic flow and completion of work may proceed in an expeditious manner. The Contractor must also notify the Owner, the Engineer and the Upper Dublin Township Police Department ten days prior to beginning of work that will affect the street.

k. Pedestrian Accommodations

Pedestrian accommodations are required at all signalized intersections unless specifically identified.

Insure all pushbuttons and signs are oriented correctly for the appropriate crossing and meet ADA and PennDOT standards (including distance from accessible curb ramp). See item in Part 2, Special Provisions for Equipment of this section.

Insure pedestrian signal heads are oriented for clear visibility for each crosswalk if required. Pedestrian signal heads to meet criteria put forth in Part 2, Special Provisions for Equipment of this section.

Insure curb ramps are ADA compliant and meet all design standards as per PennDOT's Standards for Roadway Construction RC-67M.

l. Pavement Marking Upgrade

Insure all pavement markings at the signalized intersection are improved (upgraded) if signal equipment is being upgraded in accordance to items put forth in Part 2, Special Provisions for Equipment of this section. All stop bars, crosswalks, lane lines and turn lane legends are to be upgraded.

2. Special Provisions for Equipment

The following provisions shall apply unless otherwise approved in writing by the Township:

a. Overhead Street Name Signs (Series D3-4, D3-5)

The color of overhead street name signs on the mast arm supports shall be black legend and border on a white reflectorized background. Otherwise, the signs shall conform to PennDOT Publication 236. Install signs in accordance with PennDOT Publication 408, Section 936.

b. Traffic Signal Support, Mast Arm – Stainless Steel

This work is the installation of complete and operational traffic signal supports for the mounting of traffic control devices. Traffic signal supports and mast arms shall be fabricated of stainless steel except in the Ft. Washington District, where ornamental traffic signal supports will be required.

- (1) Description – PennDOT Publication 408, Section 951.1. Revise as follows:

This work is the furnishing and installation of complete and operational stainless steel traffic signal supports for the mounting of traffic control devices. Supports are to be designed in accordance with PennDOT’s “Criteria for the Design of Traffic Related Structures”. Submit shop drawings in accordance with the criteria for review and acceptance. Provide structural calculations for all signal supports sealed by a professional engineer

- (2) Materials – PennDOT Publication 408, Section 951.2. Add the following:

- (a) Stainless Steel. Stainless steel castings, for general applications in accordance with ASTM A-890. Stainless steel accessories and hardware in accordance with ASTM A-194 and ASTM A-193.

- (b) In accordance with PennDOT Publication 408, Section 1104.02(b) except for the following:

- (i) Shaft and Arms - ASTM A-269, A-666 or A-890.

- (ii) Certification – Section 106.03(b)3. Certify that all signal supports satisfy the Department’s criteria and are adequate to support the loads specified. Certify the structural adequacy of all sign and signal brackets.

- (3) Construction – PennDOT Publication 408, Section 951.3 and as follows:

- (a) In the presence of the Engineer, field spot and mark location of new foundations.

- (b) Construct Type A foundation and install anchor bolts in accordance with PennDOT Standard TC-7801 for the indicated mast arm length.

- (c) Drill and grommet wiring holes for signals and pushbuttons shown on the Plan, including holes for installation of emergency preemption devices.

c. Ornamental Traffic Signal Supports – Mast Arm and Pedestal Poles
[Specified for traffic signals in the Ft. Washington District.]

- (1) Description – This work is the installation of complete and operational ornamental traffic signal supports for the mounting of traffic control devices. Supports are to be designed in accordance with PennDOT’s “Criteria for the Design of Traffic Related Structures”. Submit shop drawings in accordance with the criteria for review and acceptance. Provide structural calculations for all signal supports sealed by a professional engineer. Provide ornamental traffic signal support mast arm and ornamental base meeting the follow specifications:
- (2) Materials – PennDOT Publication 408, Section 951.2 and as follows:

Supports manufactured by:

Valmont Industries, Inc.
Valley, Nebraska 68064

- (a) Mast Arm Pole: Valmont ornamental steel, fluted (16 sharp), tapered, traffic signal pole shaft and mast arm, painted gloss black over galvanized.
 - (i) Steel Support Pole – Fluted (16 sharp) steel shaft, tapered at 0.14 inches per foot, with Simplex clamp assemble for mast arm connection, topped with a 10-inch diameter anodized aluminum “gold” ball, or a tenon connection for luminaire, as required.
 - (ii) Steel Mast Arm – Fluted (16 sharp), curved design, tapered at 0.14 inches per foot, with Simplex clamp assembly for attachment to pole shaft.
 - (iii) Pole Base – HN25XT high-strength, elastomeric polyurethane “Xtreme” Composite Decorative Base (black).
 - (iv) Base Plate and Anchor Bolts – Provide bolt circle and anchor bolts in accordance with Valmont design drawing for the indicated mast arm length.

- (b) Pedestal Support Pole: Valmont ornamental steel, fluted (16 sharp), tapered, traffic signal pedestal poles (10' and 14' length), painted gloss black over galvanized.
 - (i) Pole – Fluted (16 sharp), steel shaft, tapered at 0.14 inches per foot, topped with a tenon connection for attachment of a 22D finial.
 - (ii) Pole Base – HN18XT high-strength elastomeric Polyurethane “Xtreme” Composite Decorative Base (black).
 - (iii) Base Plate and Anchor Bolts – Provide bolt circle and anchor bolts in accordance with Valmont design drawing.
 - (c) Luminaire – Provide tenon connection at top of pole for luminaire attachment at locations noted on plans.
 - (d) Signal Heads – Use polycarbonate signal heads, with color impregnated in material to match ornamental poles.
 - (e) Galvanizing and Paint Finish – Poles, arms and other structural steel items to be prepared per Valmont “F-283 ValCoat” (Galvanized-Powder Top Coat) specification. Finish paint is to be gloss black.
 - (f) Certification – PennDOT Publication, Section 106.03(b)3. Certify that all signal supports satisfy the Department’s criteria and are adequate to support the loads specified. Certify the structural adequacy of all sign and signal brackets.
- (3) Construction – PennDOT Publication 408, Section 951.3 and as follows:
- (a) In the presence of the Engineer, field spot and mark location of new foundations.
 - (b) Construct PennDOT Type A foundation and install anchor bolts in accordance with Traffic Standards - SignalsTC-7801 (June 1989) for the indicated mast arm length.

- (c) Drill and grommet wiring holes for signals and pushbuttons shown on the plan, including holes for installation of emergency preemption beacons.
- (d) All pole attachments to be done as follows:
 - (i) All overhead signals shall be installed using signal mounting plates with U-bolts.
 - (ii) All signs subject to significant wind loading shall also be attached to the pole using signal-mounting plates with U-bolts. Overhead street name signs may have to be attached to swing brackets, u-bolted to the mast arm.
 - (iii) All other pole attachments including, but not limited to, side-mount signals, pushbuttons, signs not subject to significant wind loadings, preemption devices, etc., shall be installed with paintable connecting hardware, tapped and screwed directly into the pole.
 - (iv) The use of painted or unpainted stainless steel banding will not be permitted.
- (e) If polycarbonate signals are unavailable, such as for “Hand/Man” signals, paint aluminum signals, as well as sign and signal hanger brackets to match the signal support finish in accordance with the following specifications:

“Apply one (1) coat of Sherwin Williams polyamide epoxy primer to a DFT of 4-6 mils to all exterior surfaces. Finish paint with one (1) coat of Sherwin Williams gloss black, polyurethane enamel corothane, polane 2.8 plus or hi-solids polyurethane to a DFT of 2-3 mils.”
- (f) Coordinate with the local Valmont vendor to insure that care is taken to coordinate the aesthetic effect of all mountings to the poles. Repair all damage to the poles during installation, matching paint specifications in kind.

d. Controller Assemblies

- (1) Description – This work is the furnishing and installation of either an Econolite ASC/2S series, NEMA TS2 actuated local controller, or an Econolite ASC/2M series, NEMA TS2 master controller with Type 2 timer and Type 1 assembly, equipped with fiber optic modem for system communication, including any communication modules needed for the fiber optic communication cable as required. An internal time based coordinator is to be included in a local controller assembly.

All controllers, which are currently or are planned to operate within a coordinated corridor or system shall have the same manufacturer of controller. The brand or manufacturer of the controller must be selected so as to insure interoperability, now and in future phases of the subject development, of all controllers on the corridor or system including those owned and maintained by neighboring townships. Therefore, provide documentation of the acceptability of the manufacturer to the Township or Townships.

All other controller installations to be provided with telephone drop modems capabilities.

- (2) Material – PennDOT Publication 408, Section 950, 952.2 and as follows:

- (a) Cabinet

Furnish an aluminum cabinet meeting all the standard requirements of an Econolite Type P44 cabinet (55”h x 44.25”w x 26”d). Provide concrete foundation meeting all requirements provided in Publication 408, Section 952.2.

- (b) Controller Assembly

Furnish an Econolite ASC/2S series local controller assembly or Econolite ASC/2M series master controller assembly as required. The Controller is to have a fully prompted, menu driven programmability. The Controller to have an EEPROM memory, modular hardware design, and provide internal diagnostics with automatic and operator initiated verification of:

- (i) Memory.

- (ii) Processor Operators.
- (iii) Individual Inputs and Outputs.
- (iv) Keyboard.
- (v) Display.

A Malfunction Management Unit (M.M.U.) to be provided in each controller assembly. The unit to provide for twelve (12) channels with four (4) inputs per channel. It is to be downward compatible with TS1 type CMU's including connectors. Required B.I.U. units and detector card rack assembly to be provided and installed in accordance with TS2.

All Controllers must contain pedestrian isolation circuitry and surge protection on all controller inputs. All controller cabinets must include fiber optic telemetry equipment.

Controllers at stand-alone intersections must have an Intersection Monitor II, as manufactured by Econolite Control Products and a Township approved dial-up modem.

(c) Police Panel:

A small hinged and gasket sealed auxiliary door to be included on the outside of the main cabinet door. The auxiliary door will not allow access to the controller, its associated equipment or exposed electrical terminals but will allow access to a Police Panel. The Police Panel will be provided with the following switches:

- (i) Auto/Flash.
- (ii) Lights (ON-OFF).
- (iii) Automatic/Manual.
- (iv) Main Power (ON-OFF-Generator).

A flexible cord with pushbutton is to be provided with a standard police lock. Two (2) keys for the auxiliary door will be provided with each cabinet.

- (d) Receptacle for alternative power source (emergency generator):

A Generator/Utility Transfer Assembly shall be provided that will allow an operator to manually transfer between utility and local fed electrical power in a manner that is both safe and simple to execute. No tools shall be used to affect the transfer. The assembly shall be installed inside of a NEMA 3R cabinet measuring 14" x 10" x 7", and will be keyed to accommodate a standard traffic cabinet "police door" key. All elements of the assembly shall be designed to carry single-phase 120VAC, 60hz, electrical current at 30 amperes. The Transfer Assembly shall be so constructed to physically prevent either power source from back-feeding the other. Only one (1) power source may be connected to the load at any one (1) time. All electrical connections shall be covered or recessed within insulating materials. Instructions and schematics detailing the transfer procedure and connections shall be attached to the assembly.

The utility power shall enter the Transfer Assembly from a fused or breakered disconnect box. The generator power shall enter the Transfer Assembly from a compatible three-conductor industry standard inlet (NEMA L530P). A breaker, with amperage not to exceed the inlet's rated current, shall be connected between the inlet's "hot" leg and the transfer assembly. A compatible surge protection device (GE V150PA20A or equivalent) shall be connected between the load side of this breaker and an earth connection. The common leg of the inlet shall be connected directly to the load's neutral bus. The ground leg of the inlet shall be connected to an earth connection.

- (e) Single Mode Fiber Optic Fan-Out Kit

Furnish a factory or field installed rack mountable Fiber Optic Cable Fan-Out Kit with a capacity for full splice storage and connect functions for the number of fibers in the fiber optic cable that are being terminated and meeting the following requirements:

- (i) Provide transition from the fiber optic cables to individual fibers using fusion splices as specified in this section.
 - (ii) Provide, on the outside surface of break out box, the same number of ST type female optical connectors as that of number of fibers in the fiber optic cable that are being terminated, in order to plug in jumper cables that connect to the equipment. Provide twist-lock design for connectors.
 - (iii) Connector insertion loss: plus or minus 0.25 dB.
 - (iv) Provide a removable top panel to protect the splices and pigtailed in the break out box.
 - (v) Maximum heights of the break out box: plus or minus 1.75 inches.
 - (vi) Provide rack mounted break out boxes in all the cabinets in which fiber optic cable is terminated.
- (f) Single Mode Fiber Optic Fusion Splice

Furnish standard single-mode Fiber Optic Fusion Splices meeting the following requirements:

- (i) Compatible with 62.5/125 micron size fibers specified in this section.
- (ii) Section loss: <0.2dB.
- (iii) Back reflection: -50dB.
- (iv) Average signal loss during thermal cycling: <0.2 dB.
- (v) Operating temperature: -30C to +60C.
- (vi) Storage temperature: -40C to +70C.
- (vii) Humidity range: not exceeding 95%, non-condensing.

(g) Single Mode Fiber Optic Jumper Cable

Furnish simplex or duplex Fiber Optic Jumper Cables, of sufficient length for proper connection and routing within the cabinet as required, meeting the following requirements:

- (i) Terminated with ST-type connectors.
- (ii) Incorporate twist-lock design in the connectors for maximum holding strength.
- (iii) Provide strain relief boot at the connector.

(h) Fiber Optic Modem

Supply a fiber optic modem that meets the following specifications:

- Meets EIA RS-232C/D specifications (simplex or duplex)
- Meets NEMA TS-1/TS-2 and Caltrans Traffic Signal Control Equipment Specifications for operating temperature, humidity, shock, vibration and voltage transient protection.
- User-Selectable Local, master or bus operation and DTE or DCE interface insured ease of installation and maximum versatility
- Supports Request to Send (RTS) and Clear to Send (CTS) signals
- LED Indicators provide indication of critical operating parameters
- Solid-State Current Limiters on all power lines provide equipment protection
- Internal Battery Back-up provides a minimum of 12 hours operating time in the event of loss of 115 VAC prime operating power, and maintains continuous channel communications
- User-Configurable Optical & Electrical Anti-Streaming provides network protection against faulty streaming controller operation

Data

- Data Interface: RS-232 C/D
- Data Rate: DC to 100 kbps
- Bit Error Rate: < 1 in 10⁹ @ maximum optical loss budget
- Anti-Streaming Time-out: 4, 8, 16, 32, 64 seconds, or infinity (disabled)
- Operating Mode: Asynchronous, Simplex or Full-Duplex
- Wavelength: 1300 nm, Single Mode
- Number of Fibers: 2 In/2 Out

Connectors

- Power: Terminal Plug with screw clamps
- Data: Type DB-25S
- Optical: Type ST
- Optical Emitter: 1300 nm, Single Mode: Laser Diode
- LED Indicators:
 1. Transmit Data, optical channel 1 (TD 1)
 2. Receive Data, optical channel 1 (RD-1)
 3. Transmit Data, optical channel 2 (TD-2)
 4. Receive Data, optical channel 2 (RD-2)
 5. Power On (PWR)
 6. Fault/Antistreaming Activated
 7. Request to Send (RTS)
 8. Clear to Send (CTS)

Electrical & Mechanical

- Power: 12 VDC @ 250 mA
- Number of Rack Slots: Mount transceiver to right-side cabinet wall.
- Current Protection: Automatic Resettable Solid-State Current Limiters
- Circuit Board: Conformally coated and meets IPC Standard
- Size (in./cm.) (LxWxH): No larger than 7.0x 4.9x 1.0 in., 7.8x 12.5x 2.5 cm.
- Shipping Weight: < 2 lbs./0.9 kg

Environmental

- MTBF: > 100,000 hours
- Operating Temp: -40° C, ambient
- Storage Temp: -40° C to 85° C, ambient
- Relative Humidity: 0% to 95% (non-condensing)
- Battery Back-Up Internal, Rechargeable Nickel Metal Hydride (NIMH) Battery Operating Period: 12 hours, minimum

Have the transceiver derive its operating power from an external power supply. Plug the power supply into a standard AC receptacle. Supply connections as necessary. Supply and install a new AC receptacle if no AC receptacle is available in the existing cabinet

(i) Telephone Drop

Description– This work is furnishing and installation of a voice grade telephone modem, cable, and all the required hardware and service connections in accordance with local telephone utility specifications. The contractor is also responsible for setting up a service contract with the local telephone utility.

Material – Sections 950.2, 1104.01 and 1104.08

Telephone Modem Requirements:

General

1. Provide 2-wire full duplex communications over the dial up switched telephone network or leased lines. Provide computer controlled communications setup and configuration using the AT command set. Provide a modem with Auto-dial, Auto-answer, Auto-speed select at data rates of 300 to 9600 BPS (Bits per second).
2. Provide indicators on the front of the Modem to display:

Send Data
Received Data
Request to Send
Clear to Send
Carrier Detected

3. Provide an internal fused power supply.
4. Provide a modem that answers at the last connect speed so that the long handshake sequence can be bypassed to avoid time-out disconnects.

Functional Requirements

Provide a modem compatible with V.34, V.90, and V.92 ITU standards:

1. Data Rate: 300 to 9600 Bps
2. Frequencies:
 - Mark- 10,000 KHz
 - Space- 15,000 KHz
3. Transmit Level: 10 dbm or less
4. Timing: CTS 10 ms +/-2 ms
CD 8 ms +/-2 ms
5. Soft Carrier: 10 +/-2ms
6. Operating Temperature Range: -40°C to +85°C
7. ACIA & MODEM Interface: E1A RS-232-C and CCITT V.28 standards.
8. Power: 120V AC +/- 15%, typical 50 ma or less
9. Size: No larger than 12 in L X 6 in W X 6 cm H

- (3) Construction – PennDOT Publication 408, Sections 950.3, 952.3, 954.3 and as follows:

Connect the fiber optic cable to the proper controller terminals using fiber optic fan-out kit, fusion splices, and jumper cables.

Secure each service loop, 8 feet in length, of each jacketed fiber optic cable entering and leaving the cabinet, to the bottom of the lowest rack in the cabinet in such a way as to insure the minimum bend radius of the cable(s), and prevent interference of any kind.

Includes fiber optic fan-out kit, fiber optic fusion splice, fiber optic jumper cable, and fiber optic modem.

Monitor the operation of traffic with the programmed timings and offsets during the 30-day test period. Refine timings if needed at the request of the Township. Obtain any required PennDOT approval for timing modifications and install refined timings.

For telephone drop cable – install cables and hardware as required to provide a full duplex FSK 1200 based data transmission over a 4 wire 3002 voice grade link. Do not splice cables, except at terminal strips. Test the cable, as specified in section 954.3(I) as applicable.

Install line-to-line and line-to-ground surge protection for a peak surge current of 500A per line and a life expectancy of 100 occurrences with a response time of 1 nanosecond and operates at temperatures of -40 degrees C to +85 degrees C.

e. Emergency Pre-Emption System

(1) Description – This is the furnishing and installation of an optical Emergency Pre-Emption System at a signalized intersection in order to provide the phasing operation indicated on the Traffic Signal Plan.

(2) Material – PennDOT Publication 408, Sections 950.2 and 1104.03 shall be compatible with the Upper Dublin Township Emergency Pre-Emption System. The Township requires Opticom™ (by Global Traffic Technologies) with high and low priority, memory and vehicle ID.

Contact at the Township:

Public Works Department
(215) 643-1600 x 3801

Include all hardware and software to provide functional system.

(3) Construction – PennDOT Publication 408, Section 950.3 and in accordance with the manufacturer’s instructions.

Provide one (1) transmitter for use during testing period. Coordinate emergency pre-emption receiver alignment with the Township officials. Realign equipment as necessary to provide for the proper activation of preemption.

f. Closed Loop Software

Provide closed loop software for the supplied brand of controller and master, for purposes of monitoring and maintaining the system. Provide the software to:

Upper Dublin Township
Upper Dublin Township Traffic Consultant
PennDOT (if required by PennDOT)

This requirement is waived for a particular party if that party already has the current version of the software

g. LED Signals (Vehicular and Pedestrian)

(1) Description – PennDOT Publication 408, Section 955.1 and add the following:

- (a) Use polycarbonate signal heads, when available.
- (b) Equip each vehicular and pedestrian signal head with a Light Emitting Diode (LED) lamp indications meeting the current Institute of Transportation Engineers (ITE) specifications (January 2005).
- (c) Pedestrian signal heads to be “Hand/Man” with countdown timer module incorporated.

(2) Material – PennDOT Publication 408, Section 955.2 and add the following:

- (a) Unit Identification.

Clearly mark units on the back surface of the unit in a permanent manner showing information required for warranty and long-term performance. Provide information, which includes manufacturer name, date of manufacture, electric power requirements, signal model type and signal serial number.

(b) Physical.

Provide units with sufficient quantity and distribution of LED's to present a homogeneous appearance across the face of signal from all normal viewing planes and angles.

(c) Mounting.

Design vehicular and pedestrian LED indications for mounting in place of existing lens and lens gasket and include appropriate gasket for this purpose. Provide gasketing with a watertight seal when used with all traffic signal housings meeting existing ITE standard for signal heads and exclude the infiltration of moisture into either the signal housing or into the LED signal case.

Provide depth of such dimensions as to permit mounting in any standard traffic signal housing, subsequent to removal of existing lens, reflector, lamp and lamp receptacle.

(d) Optical.

Provide unit lens of ultraviolet (UV) stabilized, impact resistant polycarbonate, acrylic or other approved material.

Tint or similarly treat lenses to match, as near as feasible, the apparent color of the light emitted by the LED's. The lens materials used for this purpose should not significantly affect signal luminescence or chromicity.

Provide signal lens to minimize sunlight reflectance.

(e) Signal Brightness (Luminescence).

Meet requirements and specifications of the Institute of Transportation Engineer (ITE) Vehicular Traffic Control Signal Head (VTCSH) with regard to minimum luminescence over specified viewing plane and required chromicity limits.

(f) Luminescence Maintenance.

Provide minimum initial brightness of LED signal units in accordance with the luminous requirements in a standard testing procedure as defined by Section 11.04 of the

VTCSH. During the required operating life of LED signal units, provide a luminescence output of not less than sixty percent (60) percent of the values specified in this standard.

Degradation of light output over time not to exceed the following values in a standard test sample of units ordered:

- (i) “Maximum %D” is defined as luminance degradation with respect to average minimum standard brightness requirements as defined by the Institute of Transportation Engineers.
- (ii) “Actual %D” is defined as the maximum allowable cumulative degradation of a sample of signal units in luminance as compared to the average initial (calibration) value of a sample of that signal type.
- (iii) Maximum allowable values subsequent to date of installation:

<u>Months</u>	<u>Max %D</u>	<u>Actual %D</u>
0	Calibration	Calibration
12	20%	20%
24	25%	40%
48	32%	50%
72	40%	60%

- (g) Signal Color (Chromicity)

Signals to conform to current standards of VTCSH regarding chromicity requirements for traffic signals.

- (h) Electrical.

- (i) Power connector:

Provide connecting cable with PVC insulating jacket rated at 300 volts or higher. For each signal indication, provide each unit with two (2) conductor insulated AWG #16 connecting cable of twenty-four (24) inch length, with each of the two (2) conductors terminated with .25 inch spade lug connectors.

(ii) Operating voltage:

Fully operate units over a range of 90 volts to 130 volts at 60 Hz.

(iii) Surge protection:

Provide each unit with integral surge protection to withstand transient current of 600 volts, 100 microsecond rise and 1 millisecond pulse width. Provide full electrical and physical surge protection to all unit components.

(iv) Power consumption:

Maximum permissible power consumption to ambient conditions (normal 120 volts, 60 Hz., 70 degrees F.), as follows:

8-inch ball: 12 watts
12-inch ball: 20 watts

Power consumed not to vary by more than twenty percent (20%) from nominal power consumption over voltage range of 105 volts to 125 volts, and over permissible environmental ranges.

(i) LED Current Limitations.

Average forward current through any light emitting diode (LED) in the unit not to exceed 30 milliamperes.

(j) Environmental.

Fully operate units at temperature ranges of -40 degrees F. (-40 degrees C) to +165 degrees F. (+74 degrees C) at up to 100 percent relative humidity.

(k) Phantom Light Emission.

Provide units that do not emit visible light when subjected to a 4 milliamp or less leakage current from a solid-state load switch in an off condition.

(l) Product Consistency.

Provide all units with a consistent design, using similar components, quality control methods and assembly procedures. Provide all units with similar LED bin quality and brightness.

(m) Luminescence vs. Voltage Maintenance.

Provide minimum light output within thirty-five percent (35%) of required test values shown for cumulative times shown for test units over permissible voltage range as required in “Luminescence Maintenance” section.

(n) Definition of Failure.

For purposes of this specification, failure of a signal unit is defined as an occurrence where:

(i) The luminescence of the signal measured in candela in standard test procedures is less than the required initial luminescence or luminescence at time points and conditions specified.

(ii) Two or more series of LED’s or in excess of twenty percent (20%) of LED’s are not operable.

(3) Construction – PennDOT Publication 408, Section 955.3.

h. Communication Cable, Aerial Fiber Optic, Single-Mode Fibers

(1) Description - This work is the furnishing and installation of cable of the indicated type and hardware to provide communications between local controllers. This work also includes all equipment needed to determine splice losses, attenuation losses, cable integrity and fiber distance data.

(2) Material - Provide cable with weatherability and durability characteristics suitable for outdoor exposed installation. Provide all hardware for attaching cable to wood utility poles and mast arms as indicated.

(a) Fiber Optic Cable

Furnish a self-supporting, rodent and lightning proof, gel-filled, loose-tube, single-mode, fiber optic cable with integral messenger cable which conforms to the latest publications of Electronic Industries, Association/Telecommunications Industry Association (EIA/TIA) and Rural Electrification Agency (REA) PE-90 and as follows:

(b) Fiber Specifications

- Optical Fiber: Provide cable with single mode fibers with a core diameter of 8.3 μm .
- Optical Performance: Provide cable with attenuation of 0.5 dB/km and Nominal Zero Dispersion Slope of 0.092 ps/(nm²-km). Numerical aperture of 0.13.
- Fiber Proof Test: Provide fibers subjected to a minimum proof stress of 0.7 GPa (100 kpsi).

(c) Cable Specifications

- (i) Number of Fibers: 6: Color coded with six different colors.
- (ii) Cable Type: Heavy duty, loose tube.
- (iii) Capable of withstanding a tensile load of at least 2700 newtons during installation.
- (iv) Capable of withstanding a load of at least 800 newtons for long term application.
- (v) Minimum Bending Radius for Installation: At least 20 times the cable diameter.
- (vi) Minimum Bending Radius for Long Term Applications: At least 10 times the cable diameter.
- (vi) Coating Diameter: 250 microns.
- (viii) Cable Structure, beginning from outer layer as follows:
 - UV acrylate fiber coating/polyethylene outer sheath.
 - Polyethylene jacket with kevlar ripcord.
 - Kevlar braid.
 - PVC jacket with a kevlar ripcord.
 - Spiral wrapped Mylar tape.
 - Six gel filled loose buffer tubes.

- One color coded, single mode optical fiber in each tube.
 - One dielectric kevlar rod as a central strength member.
 - A nontoxic and dermatologically safe flooding compound to inhibit water flow.
- (ix) Operating Temp.: -40 degrees C to 80 degrees C.
- (x) Installation Temp.: -30 degrees C to 60 degrees C.
- (xi) Storage Temp.: -40 degrees C to 80 degrees C.
- (xii) Relative Humidity: Not exceeding 95%, non-condensing.
- (xiii) Equipped with a disposable pulling eye on one end of the cable.
- (xiv) Integral messenger cable: Minimum 7 wire galvanized steel strand per ASTM A640.
- (xv) Supply cable on reels in continuous lengths with a minimum of 10 feet spare cable available on both sides of the cable for testing. Label clearly the following information on each reel:
- (a) Customer name and address.
 - (b) Order number.
 - (c) Reel number.
 - (d) Destination.
 - (e) Ship date.
 - (f) Manufacturer's name, address, and telephone number.
 - (g) Manufactured date.
 - (h) Cable code.
 - (i) Length of cable.
 - (j) Listing of color codes for fibers.
- (xvi) Outside plant cables conform to the requirements of Rural Electrification Administration Specification – “REA Specification for totally filled fiber optic cable, PE-90”.
- (xvii) Provide cable with weatherability characteristics suitable for outdoor exposed installation.
- (3) Construction – PennDOT Publication 408, Sections 950.3, 953, 954 and as follows:

- (a) Install hardware required to attach fiber optic cable to utility poles and traffic signal supports as indicated.
- (b) Provide a minimum of 30 feet of spare cable looped and attached at the nearest utility pole for each cable entering and leaving the controller cabinet and traffic signal support.
- (c) Connect fiber optic cable to controllers using fan-out kit and fiber optic fusion splices. No additional splices between controllers are allowable.
- (d) Carefully cut outer jacket and remove messenger cable where fiber optic cable will be enclosed within a conduit, signal support, or controller cabinet.
- (e) Test each fiber optic strand in the presence of the Township representatives to determine dB loss of the fiber optic cable. Test each fiber optic strand using a certified fiber optic testing technician utilizing standard Optical Time Domain Reflectometer (OTDR) instruments. Provide a fiber optic trace graphic showing attenuation over distance along with pairs of connections, splices, and faults. Replace fiber optic cable run if OTDR testing reveals unsatisfactory dB loss, as per manufacturer's recommendation, for the individual run, based on length of run.

Includes furnishing and installation of all mounting hardware.

i. Removal of Existing Traffic Signal Equipment

Give twenty-four (24) hours advance notice to the Township prior to delivery of existing equipment.

Deliver equipment to the following location:

Upper Dublin Township Maintenance Yard
801 Loch Alsh Avenue
Ft. Washington, PA 19034
Attention: *Public Works Department* (215) 643-1600 x 3801

j. School Speed Zone Flasher

Provide a Wall-Box Light Unit with cast guard and glass globe on back side of PennDOT approved (#0535-S001) School Signal at new or refurbished location. Install according to manufacturer's instructions.

k. Pavement Markings

Furnish and install thermoplastic pavement markings in accordance with Publication 408, Section 960. Determine with the Township the appropriate style of crosswalk markings that are to be installed for the project.

Insure any and all conflicting markings are removed in their entirety per Publication 408, Section 963.

N. Miscellaneous Standards

1. General

Before placing any base material in a street, all underground work must first have been installed (including individual building or lot services and laterals) and tested for leaks, as applicable in the presence of a representative of the Township or applicable utility. No backfilling of trenches or other backfilling shall be performed except in presence of a representative of the Township. Copies of all material slips shall be provided to the Township Inspectors or representatives daily.

2. Rock

Rock excavation shall be accomplished by drilling and wedging or blasting as permitted. Rock shall be fully taken out at least twenty-five (25) feet in advance of pipe laying and to a depth at least eight (8) inches below the bedding for pipe. Rock excavation for structures shall be removed to the bottom of concrete.

3. Blasting

Blasting for excavation shall be permitted only after securing the written permission of the Township. Appropriate insurance in amounts specified by the Township shall be provided prior to any blasting. The Township reserves the right to regulate the time of blasting and all protective measures required for safety. The type, strength of explosives used, and storage facilities shall also be approved by the Township. All handling of explosives and blasting operations shall be done by a workman licensed for this work.

4. Shoring

Excavation for pipe and structures shall be properly and adequately shored at all times in strict conformance with all OSHA Regulations.

5. Over Excavation

Should the excavation be inadvertently cut to a depth greater than required by the plans or should the Engineer require greater depth to remove unsuitable material, backfilling to the proper grade shall be done with 2A stone material as the situation requires.

6. Storage of Excavated Materials

a. The contractor shall classify, separate and store materials as may be required for reuse in backfilling, repaving or replacing topsoil. If he prefers not to separate surface materials, he shall furnish replacement materials of equal quantity and quality as directed to replace the displaced material.

b. Excavated material shall be placed outside Township rights-of-way and in a fashion so as not to interfere with traffic on the streets and driveways in an unreasonable manner. All surplus excavated material shall be removed from the site of the work and disposed of but none shall be deposited on private property until written consent of the owner has been obtained and a copy filed with the Township.

7. Maintaining Traffic on Existing Streets

Vehicular traffic lanes on existing streets shall be kept open at all times in accordance with applicable work zone protection standards. Signs, barricades, fences, and other protective devices as may be required shall be installed and maintained.

8. Tracking Mud

Only approved equipment shall be permitted for transporting loose or wet materials. Vehicle tires shall be cleaned prior to leaving the job site as necessary to prevent the tracking of mud or dust in the existing public travel way. Any mud, debris or other materials inadvertently left in the right-of-way shall be immediately cleared from the road way in accordance with Township ordinances.

9. Tunneling and Jacking

- a. All methods of tunneling or jacking shall be approved by the Engineer and conform to PennDOT Publication, Form 408. Tunnels shall be of sufficient size to allow proper pipe installation. Tunnels shall be timbered to the extent necessary as directed by the Engineer.
- b. Where rock is encountered in a tunnel, it shall be removed to the lines prescribed by the Engineer.
- c. Tunnel sections shall be backfilled with suitable material and compacted by ramming and tamping from each end or grouted to provide proper stabilization.
- d. Pipes utilized as a sleeve or tunnel shall be demonstrated to be adequate to convey the material and live loads as well as function to convey the water, stormwater, sewage or other material.

10. Dewatering

- a. All excavations shall be kept free of water during construction of structures, roads, pipe laying and backfilling operations. Temporary flumes, channels or pipes shall be used to divert water from the excavation.
- b. All water from any source shall be pumped or bailed to provide a dry trench and shall be discharged in such manner as not to cause injury to work completed, damage to property, health hazards or impediment to traffic. In no case shall water be permitted to rise into or flow through a completed sewer unless permitted by the Township.

11. Cleanup

Upon the completion of any work described in this or other Sections herein, the area shall be thoroughly cleaned and all dirt, debris, materials, tools and equipment shall be removed, hauled away, all to the satisfaction of the Township. Any paving or concrete surfaces damaged as a result of the construction shall be restored to the satisfaction of the Township.

12. Removable Bollards

Proposed removable bollard must be approved by Upper Dublin Township. The Township has approved the following removable bollards:

- a. Secure USA – Fire Bollard Series (SU-BX300)
Corporate Headquarters – Atlanta
- b. Maxi Force Traffic Control Bollards – Round and standard hydrant – wrench operated bollard. Models MR-RW-RS1-R or MR-RW-RS2-R.
Type of head to be determined by Township.

APPENDIX A

UPPER DUBLIN TOWNSHIP
POLICIES AND PROCEDURES
SUBMISSION OF SUBDIVISIONS AND LAND DEVELOPMENTS

1. Initial submissions are made to the Office of Code Enforcement.
 - A. Submissions are received and date stamped in the Code Enforcement Office.
 - B. Completed and signed application and fees must be attached.
 - C. Submit twenty (20) sets of plans and five (5) copies of all reports.
 - D. Code Enforcement Department and Township Engineer check set for completeness.
 - E. If complete, Code Enforcement distributes according to the Township Ordinance.
 - F. Submissions dropped off to the Township receptionist will be returned to the Applicant.
2. Submissions made by the 10th of the month will be scheduled for the following month's Planning Commission (PC) Meeting. If the 10th is on a weekend or a holiday, the next business day will govern. EPAB, PC, Shade Tree and other committee or staff level reviews will be scheduled and dates given on distribution memo.
3. Submissions made after the 10th of the month will be automatically scheduled for the subsequent Planning Commission (PC) Meeting.
4. Incomplete submissions will be returned to the Applicant.
5. Re-submissions of all plans to the Township will require the Applicant/Owner/Developer to comply with all applicable codes/forms required by the Township to extend the Review Period.
6. Upper Dublin Township reserves the right to reject any partial plan set or incomplete plan as not meeting the minimum standards set forth in the Ordinance.
7. Recommendation for approval from the Planning, Parks/Recreation and Library Committee (PPL) will only be made upon satisfactory completion of all review comments and an Upper Dublin Township Planning Commission Review prior to the scheduled PPL Meeting.
8. Plans will not be considered for concurrent Preliminary/Final Approval unless they are Minor Subdivision or Minor Land Development.
9. Submissions requiring Conditional Use Approval by the Board of Commissioners will only be scheduled once all of the reviewing agencies have had the opportunity to comment on the application. The Applicant is responsible for securing those reviews.

10. Plans to be considered for Preliminary or Final Approval before the Board of Commissioners at the Stated Meeting must have received recommendations from the PC and PPL. **Waivers** or **deferrals** requested from the Subdivision and Land Development Chapter shall be shown on the Record Plan and requested in writing.
11. Legal Descriptions, Cost Estimates and copies of all Permits required shall also be submitted with Final Plans to expedite processing after approval. Failure to submit these items in a timely basis will delay approval, issuance of permits, or start of construction.
12. Upon Final Approval, Applicant shall sign and return to the Township a copy of the Approval Letter acknowledging his/their acceptance of the conditions. Failure to return the letter to the Township within fifteen (15) days constitutes non-acceptance of the conditions and deems the plan denied.
13. Prior to the start of construction and issuance of any permits, all easements, plans, agreements and required documents shall be recorded with the Record Plans.
14. All plans shall be recorded at the Recorder of Deeds within ninety (90) days of approval. Should the ninety (90) days pass, Applicant may be required to appear before the Board of Commissioners for re-approval of the Plan in accordance with the PAMPC.
15. Upon approval, Township Engineer shall forward to Applicant the Subdivision – Land Development Document Checklist to be completed and returned to facilitate preparation of agreements.
16. Applicant shall submit three (3) proof copies of Final Plans containing all revisions to Township Engineer. Once approved, Applicant shall forward three (3) Mylar and five (5) paper copies of the Record Plan and nine (9) complete Plan Sets to Township Engineer. Three (3) Mylar and five (5) paper copies shall be first signed and notarized by Owners/Developers. All Plans must bear the seal and signature of the responsible professional engineer or land surveyor. Completion of Township signatures and recording will be completed by the Township.
17. Post Construction Requirements
 - a. 18 month maintenance bond – 15% of construction cost estimate.
 - b. Notification to Township to inspect, release funds and dedicate.
 - c. All maintenance bonds shall be automatically extended until Township forwards a letter releasing the developer from maintenance period.

APPENDIX B

Deferral of Improvements Note:

Installation of those improvements including curb, sidewalk, roadway widening and storm sewer along the tract frontage(s) by the property Owner/Developer is hereby deferred until such time it is deemed necessary by the Upper Dublin Township Board of Commissioners, without the need for adoption of an ordinance or assessment. Within ninety (90) days of written notice from the Board of Commissioners, Owner/Developer agrees to:

- (1) Obtain an Upper Dublin Township Highway Opening Permit, Montgomery County Roads and Bridges Permit, or PADOT Permit whichever applies;
- (2) Install curb, sidewalk, roadway widening or storm sewer at no expense to Upper Dublin Township;
- (3) Waive any rights to contest a lien by Upper Dublin Township if curb, sidewalk, roadway widening or storm sewer installation is not completed within the ninety (90) day period, weather permitting. Installation of curb and related construction shall conform to the applicable Township ECSIP and PADOT Construction Standards, whichever may be greater, in force at time of notice.

APPENDIX C

CORPORATE ACKNOWLEDGEMENT

COMMONWEALTH OF PENNSYLVANIA:
COUNTY OF MONTGOMERY :

ON THIS, THE _____ DAY OF _____, 20____, BEFORE ME, A NOTARY PUBLIC IN AND FOR THE ABOVE COUNTY AND COMMONWEALTH, PERSONALLY APPEARED THE UNDERSIGNED OFFICER, _____ WHO ACKNOWLEDGED HIMSELF (HERSELF) TO BE THE _____ OF _____, AND THAT HE (SHE) AS SUCH OFFICER BEING AUTHORIZED TO DO SO, EXECUTED THE FOREGOING INSTRUMENT FOR THE PURPOSES THEREIN CONTAINED BY SIGNING THE NAME OF THE CORPORATION BY HIMSELF (HERSELF), AS _____. IN WITNESS WHEREOF, I HAVE HEREUNTO SET MY HAND AND OFFICIAL SEAL.

(SEAL) NOTARY PUBLIC

MY COMMISSION EXPIRES: _____

PARTNERSHIP ACKNOWLEDGEMENT

COMMONWEALTH OF PENNSYLVANIA:
COUNTY OF MONTGOMERY:

ON THIS _____ DAY OF _____, 20____, BEFORE ME, A NOTARY PUBLIC IN AND FOR THE ABOVE COUNTY AND COMMONWEALTH, PERSONALLY APPEARED _____, WHO ACKNOWLEDGED HIMSELF (HERSELF) TO BE A PARTNER (LIMITED PARTNER) OF _____ AND THAT HE (SHE), AS SUCH PARTNER (LIMITED PARTNER), BEING AUTHORIZED TO DO SO, EXECUTED THE WITHIN INSTRUMENT FOR THE PURPOSES THEREIN CONTAINED, BY SIGNING THE NAME OF THE PARTNERSHIP (LIMITED PARTNERSHIP) BY HIMSELF (HERSELF) AS SUCH PARTNER (LIMITED PARTNER).

IN WITNESS WHEREOF, I HAVE HEREUNTO SET MY HAND AND OFFICAL SEAL.

(SEAL) NOTARY PUBLIC

MY COMMISSION EXPIRES: _____

PERSONAL ACKNOWLEDGEMENT

COMMONWEALTH OF PENNSYLVANIA:
COUNTY OF MONTGOMERY :

ON THE _____ DAY OF _____, 20__, BEFORE ME, A NOTARY PUBLIC OF THE COMMONWEALTH OF PENNSYLVANIA, PERSONALLY APPEARED _____, WHO ACKNOWLEDGED THIS PLAN TO BE THE OFFICIAL PLAN OF STREETS AND PROPERTY SHOWN THEREON, SITUATED IN THE TOWNSHIP OF UPPER DUBLIN, COUNTY OF MONTGOMERY, COMMONWEALTH OF PENNSYLVANIA, AND DESIRED THAT THIS PLAN BE RECORDED ACCORDING TO LAW.

SEAL

NOTARY PUBLIC

MY COMMISSION EXPIRES: _____

ACCEPTANCE OF PLAN

I, _____ HAVE LAID OUT UPON MY LAND, SITUATED IN THE TOWNSHIP OF UPPER DUBLIN, COUNTY OF MONTGOMERY, COMMONWEALTH OF PENNSYLVANIA, CERTAIN LOTS AND STREETS (SITE IMPROVEMENTS) ACCORDING TO THE ACCOMPANYING PLAN WHICH IS INTENDED TO BE RECORDED. WITNESS MY HAND AND SEAL THIS _____ DAY OF _____, 20__.

OWNER SIGNATURE

APPROVAL OF TOWNSHIP

APPROVED BY THE BOARD OF COMMISSIONERS OF UPPER DUBLIN TOWNSHIP, COUNTY OF MONTGOMERY, COMMONWEALTH OF PENNSYLVANIA, ON THE _____ DAY OF _____ 20__.

PRESIDENT

SECRETARY

PLANNING COMMISSION REVIEW

REVIEWED BY THE PLANNING COMMISSION OF THE TOWNSHIP OF UPPER DUBLIN ON THIS
____ DAY OF _____ 20 ____.

CHAIRMAN

REVIEWED BY TOWNSHIP ENGINEER

DATE

TOWNSHIP ENGINEER

MONTGOMERY COUNTY PLANNING COMMISSION

MCPC No.:

PROCESSED and REVIEWED. A report has been prepared by the
Montgomery County Planning Commission in accordance with the
Municipalities Planning Code.

Certified this date: _____

For the Director

Montgomery County Planning Commission

RECORDER OF DEEDS

RECORDED IN THE OFFICE FOR THE RECORDING OF DEEDS IN AND FOR THE COUNTY OF
MONTGOMERY, AT NORRISTOWN, PA, IN PLAN BOOK NO. _____ PAGE NO. _____ ON
_____ 20 ____.

DATE

RECORDER OF DEEDS

APPENDIX D

PROFESSIONAL ENGINEER'S CERTIFICATION OF COSTS

I, _____ P.E., A LICENSED PROFESSIONAL ENGINEER IN THE COMMONWEALTH OF PENNSYLVANIA, EMPLOYED BY _____, DO HEREBY CERTIFY ON BEHALF OF _____, ACCORDING TO MY PROFESSIONAL OPINION, THAT THE FOREGOING COSTS ARE A FAIR AND REASONABLE ESTIMATE IN ACCORDANCE WITH THE PENNSYLVANIA MUNICIPALITIES PLANNING CODE, 53 P.S. §10509(g), BASED ON PLANS PREPARED BY _____, DATED _____, AND LAST REVISED _____.

PROFESSIONAL ENGINEER

LICENSE NO.

DATE

PROFESSIONAL LAND SURVEYOR CERTIFICATION

I HEREBY CERTIFY THAT THIS PLAN REPRESENTS A FIELD SURVEY MADE BY ME OR UNDER MY SUPERVISION, THAT ALL PROPERTY CORNERS ARE EXISTING OR SET AS SHOWN HEREON, THAT ALL GEOMETRIC DETAILS AS SHOWN ARE CORRECT, AND THAT ALL LOTS OR TRACTS HAVE A BOUNDARY CLOSURE ERROR OF 1:10,000 OR BETTER.

PROFESSIONAL LAND SURVEYOR

LICENSE NO.

DATE

PROFESSIONAL ENGINEER'S CERTIFICATION

I, _____, DO HEREBY CERTIFY THAT I AM A REGISTERED PROFESSIONAL ENGINEER, LICENSED IN COMPLIANCE WITH THE LAWS OF THE COMMONWEALTH OF PENNSYLVANIA; THAT THIS PLAN WAS PREPARED BY MYSELF OR UNDER MY SUPERVISION AND THAT SAID PLAN COMPLIES WITH ALL ORDINANCES AND REGULATIONS OF THE TOWNSHIP WITH THE EXCEPTION OF VARIANCES PREVIOUSLY GRANTED BY THE ZONING HEARING BOARD.

PROFESSIONAL ENGINEER

LICENSE NO.

DATE

APPENDIX E

SUBDIVISION-LAND DEVELOPMENT DOCUMENT CHECKLIST

NAME:
FILE NO.
DATE:

ITEMS NEEDED PRIOR TO PREPARATION OF DOCUMENTS, RECORDING OF PLANS, AND START OF CONSTRUCTION (☒):

- ☒ Legal descriptions for all rights-of-way, easements, lots, open space, floodplain or deed restricted areas for our review and approval:
1. Drainage Easements.
 2. Road R/W Dedication.
 3. Sanitary Sewer Easements.
- ☒ Cost Estimate of Improvements. Once accepted by Township, estimate will need to be certified in accordance with PAMPC Section 10509 by design professional.
- ☒ Length of time required to complete construction. If more than one (1) year, additional ten (10) percent of contingency may be required.
- ☒ Copy of State Highway Cost Estimate as submitted to PADOT.
- ☒ Copy of current deed.
- ☒ Certificates of Insurance to Township in accordance with Developers' Agreements.
- ☒ Name, address, phone, fax, and contact person of financial institution guaranteeing construction escrow.
- ☒ Type of construction escrow proposed. Letter of Credit, cash, Tri-Party Agreement with bank or bond.
- ☒ Property information:
- a. Name, address of Owner of record.
 - b. Name, address of Developer.
 - c. Tax Parcel Number, Deed Book and Page.
 - d. Street address of property.
 - e. Total tract size before development.
- ☒ Revisions in accordance with Final Approval conditions. Submit three (3) Proof Plan Sets to Township Engineer (following Final Approval).
- ☒ Seek and obtain approval of the Township Solicitor for all wording of acknowledgements and certifications on the Plan.

Page 2 of 2
Documents Checklist

- Nine (9) complete sets of Plans signed and sealed for construction (after proofs have been approved) and a digital copy of all materials submitted in a .pdf format.
- Three (3) linen (or Mylar) and five (5) paper copies of Record Plans, signed and sealed by engineer/surveyor, signed and notarized by Owner/Subdivider (once proofs have been approved).
- Disk with digital files (.pdf format) of entire 'approved for construction' plan set.
- Copies of all reviews, permits and approvals:
 - Bucks County Water & Sewer Authority – sewer commitment to serve letter.
 - BCW&S Authority – Approval of Sewer System Design (Carroll Engineering).
 - Water Company - commitment to serve letter.
 - Upper Dublin Township Public Works Department review.
 - Upper Dublin Township Parks and Recreation Department review.
 - Upper Dublin Township Environmental Protection Advisory Board review.
 - Upper Dublin Township Planning Commission review.
 - Upper Dublin Township Planning Consultant Review.
 - Upper Dublin Township Shade Tree Commission review and approval.
 - Upper Dublin Township Traffic Engineer review – Orth Rodgers.
 - Upper Dublin Township Fire Marshal review.
 - Montgomery County Planning Commission review.
 - Montgomery County Conservation District review.
 - Erosion and Sediment Control Plan Approval.
 - NPDES Permit for earth disturbance.
 - PADEP
 - Planning Modules.
 - Sanitary Sewer Extension Permit.
 - General Permits.
 - PennDOT:
 - Highway Occupancy Permit for widening, drainage and roadway improvements.
 - Driveway Permit.
 - Utility Permit.
 - Traffic Signal Permits.
 - PA Turnpike Commission
 - Emergency Ramp Connection.
 - Drainage review.
 - Delaware River Basin Commission
- Other:

APPENDIX F

UPPER DUBLIN TOWNSHIP AS-BUILT PLAN REQUIREMENTS

The following is a listing of the minimum physical features, utility lines, service connections and public facilities required to be 'As-Built' for purposes of establishing a permanent public record of improvements made in conjunction with development. As-Built Surveys must be performed after the completion of all improvements associated with a project, including following placement of final wearing courses and final grading of stabilized topsoil on basins, open space and vegetative rights-of-way. Plans shall be a maximum size of 24" x 36".

All As-Built Plans must be prepared, signed and sealed by a PA Registered Professional Engineer or Registered Professional Land Surveyor. As-Built Plans must be submitted for review prior to any project entering into the 18-month maintenance period as prescribed by the PA MPC. Acceptance of As-Built Plans, certification of all monumentation (including lot corners) is required prior to dedication of facilities. Upon acceptance and approval of the As-Built Plans, an AutoCAD (.dwg) file is also required.

1. **Sanitary Sewer** – Manhole locations, manhole numbers, rim elevations, invert elevations, pipe size, lateral location and grade between manholes and direction of flow.
2. **Storm Sewer** – Manhole and grate elevations, structure numbers per approved plans, inverts, sizes, grades between structures, headwall locations including types, wall and invert elevations, extent of installed outfall protections (i.e. rip-rap or channel liners) and direction of flow.
3. **Detention Basin** – Grading, As-Built volume (before and after topsoil placement), emergency spillway, top of berm and low flow channel widths and elevations, outlet structure location, orifice sizes, top of structure and invert elevations.
4. **Electric, Telephone, Cable TV** – Underground lines, above ground lines w/poles, transformers and junction boxes, depth.
5. **Water** – Main sizes, locations, valves, junctions, tees, fire hydrants, corporation stops and depth.
6. **Gas** – Underground line locations, depths, valves and cathodic protection.
7. **Sidewalk** – Offsets from face of curb and width at even 100-foot stations or where sidewalk may deviate from standard cross section.
8. **Walking Paths** – Location and widths at approximately 100-foot stations and/or where walkway width varies due to field adjustments.
9. **Cartway** - Width (curb to r/w centerline to curb) and centerline elevations at even 100-foot stations.
10. **Buildings** – Building corners with measured offsets to property lines, finished floor elevations (as required by Township).

APPENDIX G

PRE-CONSTRUCTION MEETING CHECKLIST

1. Requirements Included
 - A. Contractor participation in Pre-Construction conferences.
2. Related Requirements
 - A. Instruction to bidders; Pre-Bid Conference.
 - B. Section 01000 – Summary of work and method of payment.
3. Pre-Construction Meeting
 - A. Owner will schedule meeting one (1) week prior to Notice to Proceed.
 - B. Attendance; Owner, Engineer and Contractor.
 - C. Agenda.
 - 1) Discuss questions on Bonds and Insurance Certificates (if any).
 - 2) Execution of Owner-Contractor Agreement.
 - 3) Distribution of Contract Documents.
 - 4) Submittal of List of Sub-Contractors and Progress Schedule.
 - 5) Designation of Responsible Personnel.
 - 6) Procedures and processing of Field Decisions, Submittals, Substitutions, Applications for Payment, Proposal Requests, Change Orders and Contract Closeout Procedures.
 - 7) Review Grant Chart as prepared by Contractor.
 - 8) General Township Requirements.

PRE-CONSTRUCTION MEETING AGENDA

1. Introductions
2. General Discussion of the Project
3. Tentative Work Schedule
4. Tentative Inspection Schedule
5. Developer/Contractor Responsibilities
6. Defective Work and Quality Control Procedures
7. Escrow Disbursement Request Procedures
8. As-Built Requirements



UPPER DUBLIN CONSTRUCTION DETAILS

10-2013

NAME	PAVING DETAILS
RD100	TYPICAL CROSS SECTION OF RESIDENTIAL STREETS
RD101	TYPICAL CROSS SECTION OF SECONDARY STREETS
RD102	TYPICAL CROSS SECTION OF PRIMARY STREETS
RD103	TYPICAL CROSS SECTION OF ARTERIAL STREETS
RD104	WIDENING OF RESIDENTIAL ROADS
RD105	WIDENING OF SECONDARY ROADS
RD106	WIDENING OF PRIMARY ROADS
RD107	WIDENING OF ARTERIAL ROADS
RD108	TEMPORARY ROAD RESTORATION WITHIN TOWNSHIP ROADS
RD109	PERMANENT ROAD RESTORATION WITHIN TOWNSHIP ROADS
RD110	STATE HIGHWAY PERMANENT RESTORATION DETAILS
RD111	SINGLE FAMILY BITUMINOUS DRIVEWAY
RD112	MULTI FAMILY RESIDENTIAL AND NON-RESIDENTIAL BITUMINOUS DRIVEWAY
RD113	EMERGENCY ACCESS DETAIL
RD114	WALKING PATH DETAIL
RD115	PARKING SPACE DETAIL
RD116	HANDICAPPED PARKING SPACE DETAIL
RD117	WHEEL STOP DETAIL
RD118	OVERLAY TRANSITION WITH PAVING NOTCH
RD119	PERMANENT DRIVEWAY AND PARKING LOT RESTORATION
RD120	TIMBER GUIDE RAIL
RD121	TYPICAL DRIVEWAY DETAIL
CC200	PROPOSED SIDEWALK
CC201	CURB RAMPS
CC202	CONCRETE DRIVEWAY RAMP
CC203	CONCRETE DRIVEWAY RAMP W/ CURBED RADIUS RETURNS
CC204	CONCRETE CURB (ISOMETRIC)
CC205	CONCRETE LOW FLOW CHANNEL
CC206	BELGIAN BLOCK CURB AND PAVING DETAIL

NAME	DRAINAGE DETAILS
DR322	PERMANENT TRASH RACK
DR323	REINFORCED PRECAST CONCRETE ANTI-SEEP COLLAR
DR324	TYPICAL TRENCH DETAIL CIRCULAR STORM SEWER
DR325	TYPICAL TRENCH DETAIL CIRCULAR H.D.P.E. STORM SEWER
DR326	COMBINATION STORM SEWER AND UNDERDRAIN REINFORCED CONC. PIPE
DR327	COMBINATION STORM SEWER AND UNDERDRAIN HDPE PIPE
DR328	PERFORATED UNDER-DRAIN
DR329	PERFORATED UNDER-DRAIN SWALE AND OUTSIDE OF ROADWAY
DR330	BASIN
DR331	BASIN SPILLWAYS
DR332	GABIONS
DR333	GABIONS
DR334	COVER ADJUSTMENT SLAB STANDARD INLET & MANHOLE OPENING
DR335	COVER ADJUSTMENT SLAB FOR 4' AND 6' SPECIAL OPENING
DR336	4'X4' INLET BOX
DR337	5'X5' INLET BOX
DR338	6'X6' INLET BOX
DR339	CONVERTING PA INLET BOX TO STORM MANHOLE
DR340	CONVERTING 4' SPECIAL INLET BOX TO STORM MANHOLE
DR341	SAFETY GRATE DETAIL
DR342	CONCRETE ENCASMENT DETAIL
DR343	DOWNSPOUT SEEPAGE BED
DR343-2	ALTERNATE DOWNSPOUT SEEPAGE BED
DR344	PRECAST OUTLET STRUCTURE
DR345	TROUT LOGO PLATE (TYPE 'C', 4' AND 6' SPECIAL INLETS)
DR346	TROUT LOGO PLATE (TYPE 'M' INLETS)
DR347	MINIMUM PIPE LENGTH FOR STORM TIE IN TO STRUCTURES
DR348	SEALING OF PENETRATION/OPENINGS AROUND PIPES
DR349	INLET CHANNELS
DR350	DOWNSPOUT DETAIL

NAME	DRAINAGE DETAILS
DR300	4 AND 6 FOOT SPECIAL INLETS
DR301	HOOD DETAIL
DR302	4 & 6 FOOT SPECIAL GRADE ADJUSTMENT RINGS
DR303	INLET FRAMES
DR304	STRUCTURAL STEEL GRATE, BICYCLE SAFE
DR305	STRUCTURAL STEEL GRATE
DR306	TYPE M INLET
DR307	TYPE C INLET
DR308	INLET BOXES/INLET BOX TYPES
DR309	TYPE M & C GRADE ADJUSTMENT RINGS
DR310	PRECAST CONCRETE STORM MANHOLE
DR311	CAST IRON STORM SEWER MANHOLE FRAME AND COVER
DR312	DROP FRONT MANHOLE STEP (COPOLYMER POLYPROPYLENE)
DR313	DROP FRONT ALUMINUM MANHOLE STEP
DR314	TYPE D ENDWALL
DR315	TYPE D ENDWALL 3:1 SLOPE
DR316	TYPE D ENDWALL 4:1 SLOPE
DR317	TYPE D ENDWALL 5:1 SLOPE
DR318	TYPE D-W ENDWALL W/CUTOFF WALL, 3:1 SLOPE FOR UPSTREAM HEADWALLS
DR319	TYPE D-W ENDWALL W/CUTOFF WALL, 4:1 SLOPE FOR UPSTREAM HEADWALLS
DR320	TYPE D-W ENDWALL W/CUTOFF WALL, 5:1 SLOPE FOR UPSTREAM HEADWALLS
DR321	ORIFICE PLATE FOR DRAINAGE CONTROL

NAME	EROSION CONTROL DETAILS
ES400	FILTER FABRIC FENCE 18"
ES401	FILTER FABRIC FENCE 30"
ES402	SUPER SILT FENCE
ES403	ROCK FILTER OUTLETS
ES404	TREE PROTECTION FENCE
ES405	ROCK CONSTRUCTION ENTRANCE
ES406	CROSS SECTION RIP RAP LOW FLOW CHANNEL
ES407	SEDIMENT BASIN
ES408	SEDIMENT BASIN WITH TEMPORARY RISER & PERMANENT STRUCTURE
ES409	SEDIMENT BASIN PERMANENT STORM WATER STRUCTURES
ES410	SEDIMENT BASIN TEMPORARY RISERS
ES411	PLYWOOD BOXES AND TRASH RACKS FOR PERMANENT STRUCTURES
ES412	TEMPORARY SEDIMENT BASIN EMERGENCY SPILLWAYS
ES413	RIP RAP APRON & CHART
ES414	FILTREXX SOXX SEDIMENT CONTROL

NAME	LANDSCAPE DETAILS
LS500	TREE PLANTING AND STAKING DETAIL
LS501	SHRUB PLANTING
LS502	RESIDENTIAL STREET LIGHT STANDARD (FIXTURE)
LS503	RESIDENTIAL STREET LIGHT STANDARD (POLE, FOOTING)

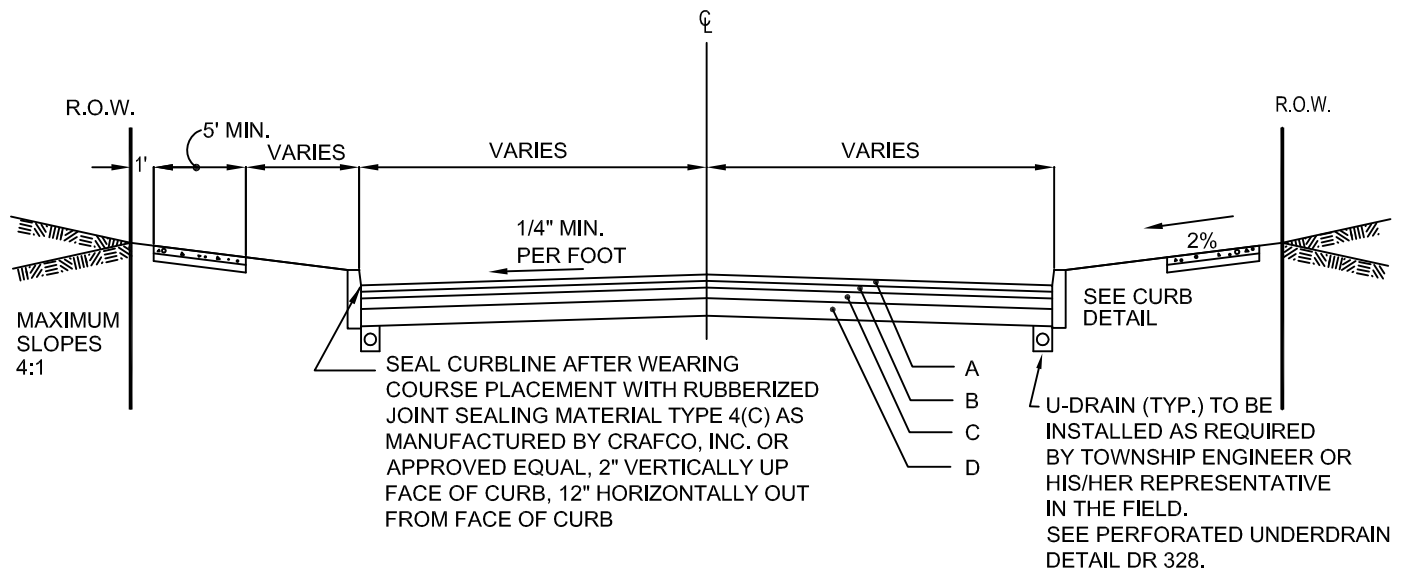

- A. 1 1/2" DEPTH SUPERPAVE ASPHALT MIXTURE DESIGN, HMA WEARING COURSE, PG 64-22, 0.0 TO 0.3 MILLION ESALs, 9.5mm MIX, SRL H
- B. 2" DEPTH SUPERPAVE ASPHALT MIXTURE DESIGN, HMA BINDER COURSE, PG 64-22, 0.0 TO 0.3 MILLION ESALs, 19.0mm MIX.
- C. 3" DEPTH SUPERPAVE ASPHALT MIXTURE DESIGN, HMA BASE COURSE, PG 64-22, 0.0 TO 0.3 MILLION ESALs, 25.0mm MIX.
- D. 6" 2A STONE

NOTES:

1. PROVIDE MATERIALS AND CONSTRUCTION IN ACCORDANCE WITH THE REQUIREMENTS OF PENNDOT PUBLICATION 408, CURRENT EDITION, INCLUDING BUT NOT LIMITED TO SECTION 210-SUBGRADE, SECTION 350-SUBBASE AND SECTION 409-SUPERPAVE MIXTURE DESIGN, STANDARD AND RPS CONSTRUCTION OF PLANT-MIXED HMA COURSES, AND AS MODIFIED HEREIN.
2. PRIOR TO APPLICATION OF ANY BITUMINOUS PAVING COURSES, PAINT ALL VERTICAL SURFACES OF CURBS, INLETS, MANHOLES, GUTTERS AND OTHER STRUCTURES TO COME IN CONTACT WITH BITUMINOUS MIXTURES WITH A UNIFORM COATING OF BITUMINOUS MATERIAL PER PENNDOT PUBLICATION 408 SECTION 401.3(g) CURRENT EDITION.

SUBGRADE STABILITY VERIFICATION

After contractor has prepared subgrade in accordance with PennDot Publication 408, Section 210 (subgrade) a subgrade stability verification is required prior to placement of sub-base material. A triaxle fully loaded maximum load (quarry slip of loaded weight will be required in the field) is required to run over entire roadway subgrade (including curb lines), over all trenches and anywhere directed by Township Engineer or his/her representatives in the field. Areas displaying pronounced elasticity, pumping, movement or deformation under the loaded triaxle will be noted and marked in the field. The areas noted and/or marked showing unstable subgrade must be corrected and reverified for required stability prior to starting subbase construction. All areas that are to be filled, stoned, paved and/or curbed are required to be proofrolled by this method. A subgrade stability re-verification is required after any/all rain events, snow events (once cleared and/or melted), introduction of moisture to the subgrade or sub-base, or as determined by the Township Engineer's representative in the field.

**UPPER DUBLIN TOWNSHIP STANDARD DETAIL
TYPICAL CROSS SECTION
OF RESIDENTIAL STREETS**



DATE 10-2013

NOT TO SCALE

RD100

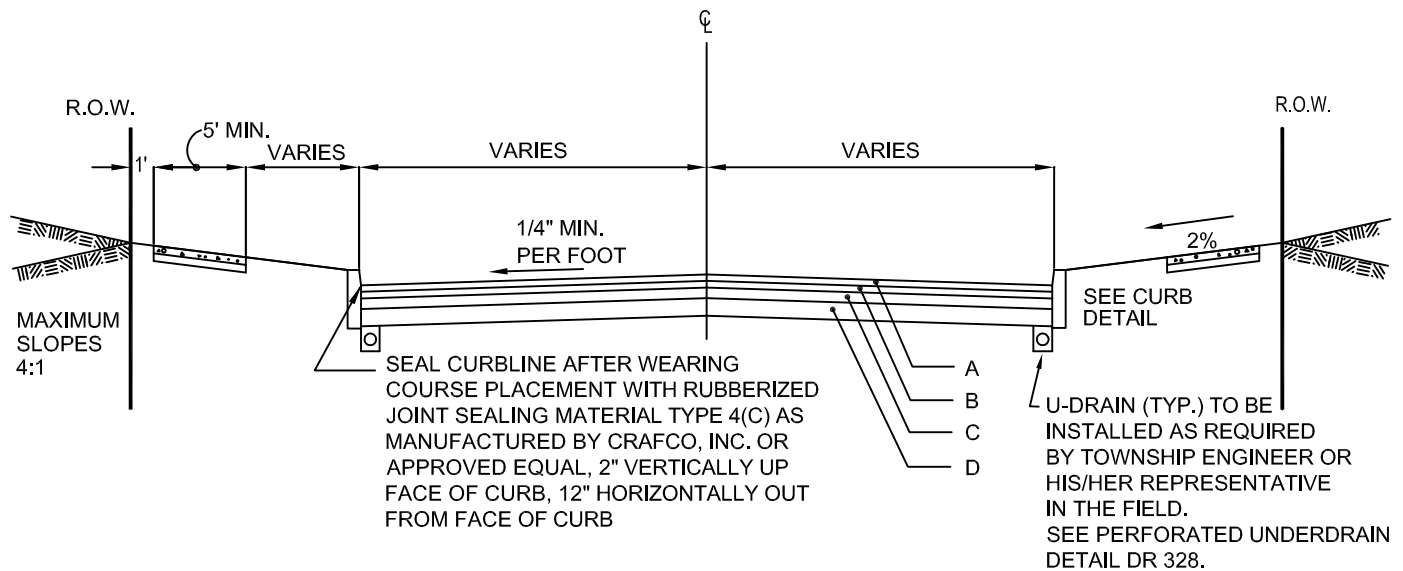

- A. 1 1/2" DEPTH SUPERPAVE ASPHALT MIXTURE DESIGN, HMA WEARING COURSE, PG 64-22, 0.3 TO 3.0 MILLION ESALs, 9.5mm MIX, SRL H
- B. 2" DEPTH SUPERPAVE ASPHALT MIXTURE DESIGN, HMA BINDER COURSE, PG 64-22, 0.3 TO 3.0 MILLION ESALs, 19.0mm MIX.
- C. 4" DEPTH SUPERPAVE ASPHALT MIXTURE DESIGN, HMA BASE COURSE, PG 64-22, 0.3 TO 3.0 MILLION ESALs, 25.0mm MIX.
- D. 6" 2A STONE

NOTES:

1. PROVIDE MATERIALS AND CONSTRUCTION IN ACCORDANCE WITH THE REQUIREMENTS OF PENNDOT PUBLICATION 408, CURRENT EDITION, INCLUDING BUT NOT LIMITED TO SECTION 210-SUBGRADE, SECTION 350-SUBBASE AND SECTION 409-SUPERPAVE MIXTURE DESIGN, STANDARD AND RPS CONSTRUCTION OF PLANT-MIXED HMA COURSES, AND AS MODIFIED HEREIN.
2. PRIOR TO APPLICATION OF ANY BITUMINOUS PAVING COURSES, PAINT ALL VERTICAL SURFACES OF CURBS, INLETS, MANHOLES, GUTTERS AND OTHER STRUCTURES TO COME IN CONTACT WITH BITUMINOUS MIXTURES WITH A UNIFORM COATING OF BITUMINOUS MATERIAL PER PENNDOT PUBLICATION 408 SECTION 401.3(g) CURRENT EDITION.

SUBGRADE STABILITY VERIFICATION

After contractor has prepared subgrade in accordance with PennDot Publication 408, Section 210 (subgrade) a subgrade stability verification is required prior to placement of sub-base material. A triaxle fully loaded maximum load (quarry slip of loaded weight will be required in the field) is required to run over entire roadway subgrade (including curb lines), over all trenches and anywhere directed by Township Engineer or his/her representatives in the field. Areas displaying pronounced elasticity, pumping, movement or deformation under the loaded triaxle will be noted and marked in the field. The areas noted and/or marked showing unstable subgrade must be corrected and reverified for required stability prior to starting subbase construction. All areas that are to be filled, stoned, paved and/or curbed are required to be proofrolled by this method. A subgrade stability re-verification is required after any/all rain events, snow events (once cleared and/or melted), introduction of moisture to the subgrade or sub-base, or as determined by the Township Engineer's representative in the field.

**UPPER DUBLIN TOWNSHIP STANDARD DETAIL
TYPICAL CROSS SECTION
OF SECONDARY STREETS**



DATE 10-2013

NOT TO SCALE

RD101

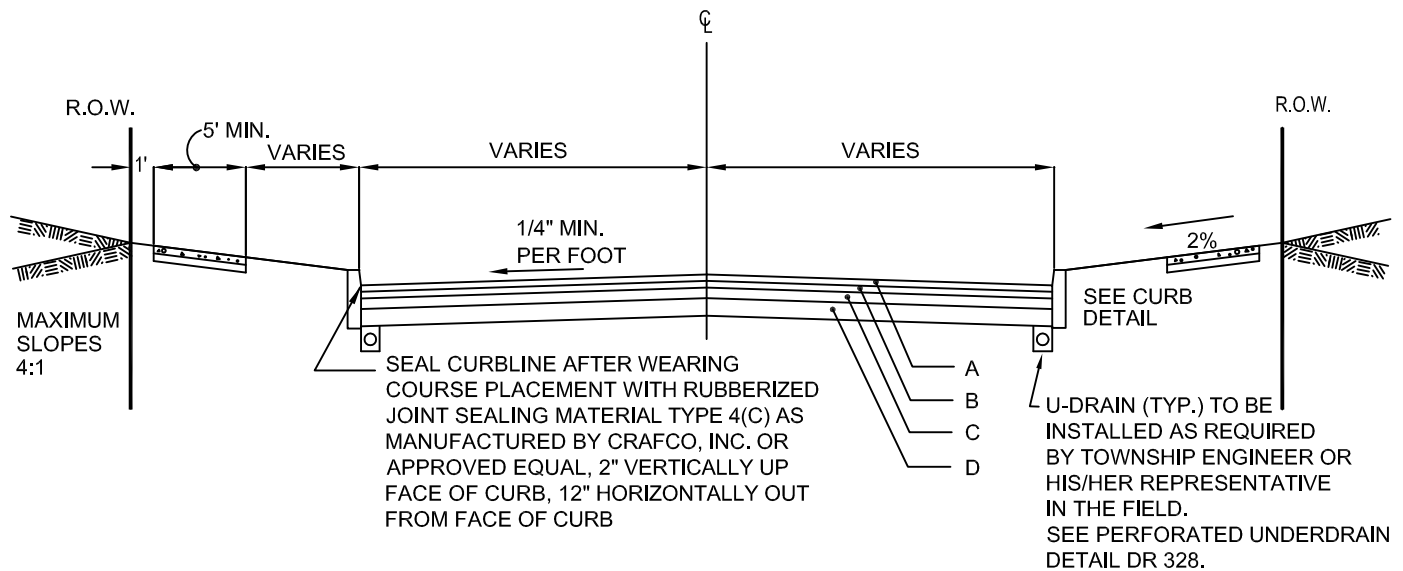

- A. 1 1/2" DEPTH SUPERPAVE ASPHALT MIXTURE DESIGN, HMA WEARING COURSE, PG 64-22, 0.3 TO 3.0 MILLION ESALs, 9.5mm MIX, SRL H
- B. 2" DEPTH SUPERPAVE ASPHALT MIXTURE DESIGN, HMA BINDER COURSE, PG 64-22, 0.3 TO 3.0 MILLION ESALs, 19.0mm MIX.
- C. 6" DEPTH SUPERPAVE ASPHALT MIXTURE DESIGN, HMA BASE COURSE, PG 64-22, 0.3 TO 3.0 MILLION ESALs, 25.0mm MIX.
- D. 6" 2A STONE

NOTES:

1. PROVIDE MATERIALS AND CONSTRUCTION IN ACCORDANCE WITH THE REQUIREMENTS OF PENNDOT PUBLICATION 408, CURRENT EDITION, INCLUDING BUT NOT LIMITED TO SECTION 210-SUBGRADE, SECTION 350-SUBBASE AND SECTION 409-SUPERPAVE MIXTURE DESIGN, STANDARD AND RPS CONSTRUCTION OF PLANT-MIXED HMA COURSES, AND AS MODIFIED HEREIN.
2. PRIOR TO APPLICATION OF ANY BITUMINOUS PAVING COURSES, PAINT ALL VERTICAL SURFACES OF CURBS, INLETS, MANHOLES, GUTTERS AND OTHER STRUCTURES TO COME IN CONTACT WITH BITUMINOUS MIXTURES WITH A UNIFORM COATING OF BITUMINOUS MATERIAL PER PENNDOT PUBLICATION 408 SECTION 401.3(g) CURRENT EDITION.

SUBGRADE STABILITY VERIFICATION

After contractor has prepared subgrade in accordance with PennDot Publication 408, Section 210 (subgrade) a subgrade stability verification is required prior to placement of sub-base material. A triaxle fully loaded maximum load (quarry slip of loaded weight will be required in the field) is required to run over entire roadway subgrade (including curb lines), over all trenches and anywhere directed by Township Engineer or his/her representatives in the field. Areas displaying pronounced elasticity, pumping, movement or deformation under the loaded triaxle will be noted and marked in the field. The areas noted and/or marked showing unstable subgrade must be corrected and reverified for required stability prior to starting subbase construction. All areas that are to be filled, stoned, paved and/or curbed are required to be proofrolled by this method. A subgrade stability re-verification is required after any/all rain events, snow events (once cleared and/or melted), introduction of moisture to the subgrade or sub-base, or as determined by the Township Engineer's representative in the field.

**UPPER DUBLIN TOWNSHIP STANDARD DETAIL
TYPICAL CROSS SECTION
OF PRIMARY STREETS**



DATE 10-2013

NOT TO SCALE

RD102

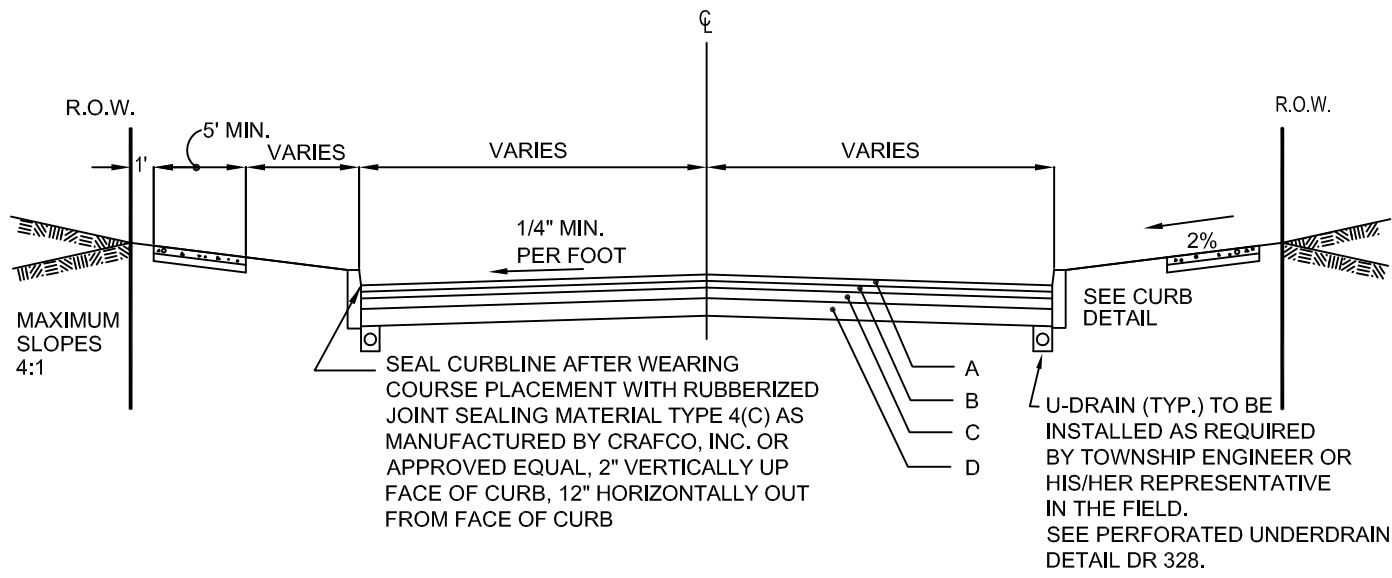

- A. 1 1/2" DEPTH SUPERPAVE ASPHALT MIXTURE DESIGN, HMA WEARING COURSE, PG 64-22, 3.0 TO 30.0 MILLION ESALs, 9.5mm MIX, SRL H
- B. 2" DEPTH SUPERPAVE ASPHALT MIXTURE DESIGN, HMA BINDER COURSE, PG 64-22, 3.0 TO 30.0 MILLION ESALs, 19.0mm MIX.
- C. 8" DEPTH SUPERPAVE ASPHALT MIXTURE DESIGN, HMA BASE COURSE, PG 64-22, 3.0 TO 30.0 MILLION ESALs, 25.0mm MIX.
- D. 6" 2A STONE

NOTES:

1. PROVIDE MATERIALS AND CONSTRUCTION IN ACCORDANCE WITH THE REQUIREMENTS OF PENNDOT PUBLICATION 408, CURRENT EDITION, INCLUDING BUT NOT LIMITED TO SECTION 210-SUBGRADE, SECTION 350-SUBBASE AND SECTION 409-SUPERPAVE MIXTURE DESIGN, STANDARD AND RPS CONSTRUCTION OF PLANT-MIXED HMA COURSES, AND AS MODIFIED HEREIN.
2. PRIOR TO APPLICATION OF ANY BITUMINOUS PAVING COURSES, PAINT ALL VERTICAL SURFACES OF CURBS, INLETS, MANHOLES, GUTTERS AND OTHER STRUCTURES TO COME IN CONTACT WITH BITUMINOUS MIXTURES WITH A UNIFORM COATING OF BITUMINOUS MATERIAL PER PENNDOT PUBLICATION 408 SECTION 401.3(g) CURRENT EDITION.

SUBGRADE STABILITY VERIFICATION

After contractor has prepared subgrade in accordance with PennDot Publication 408, Section 210 (subgrade) a subgrade stability verification is required prior to placement of sub-base material. A triaxle fully loaded maximum load (quarry slip of loaded weight will be required in the field) is required to run over entire roadway subgrade (including curb lines), over all trenches and anywhere directed by Township Engineer or his/her representatives in the field. Areas displaying pronounced elasticity, pumping, movement or deformation under the loaded triaxle will be noted and marked in the field. The areas noted and/or marked showing unstable subgrade must be corrected and reverified for required stability prior to starting subbase construction. All areas that are to be filled, stoned, paved and/or curbed are required to be proofrolled by this method. A subgrade stability re-verification is required after any/all rain events, snow events (once cleared and/or melted), introduction of moisture to the subgrade or sub-base, or as determined by the Township Engineer's representative in the field.

**UPPER DUBLIN TOWNSHIP STANDARD DETAIL
TYPICAL CROSS SECTION
OF ARTERIAL STREETS**

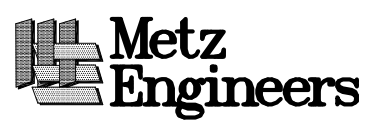

DATE	10-2013	NOT TO SCALE	RD103
------	---------	--------------	-------

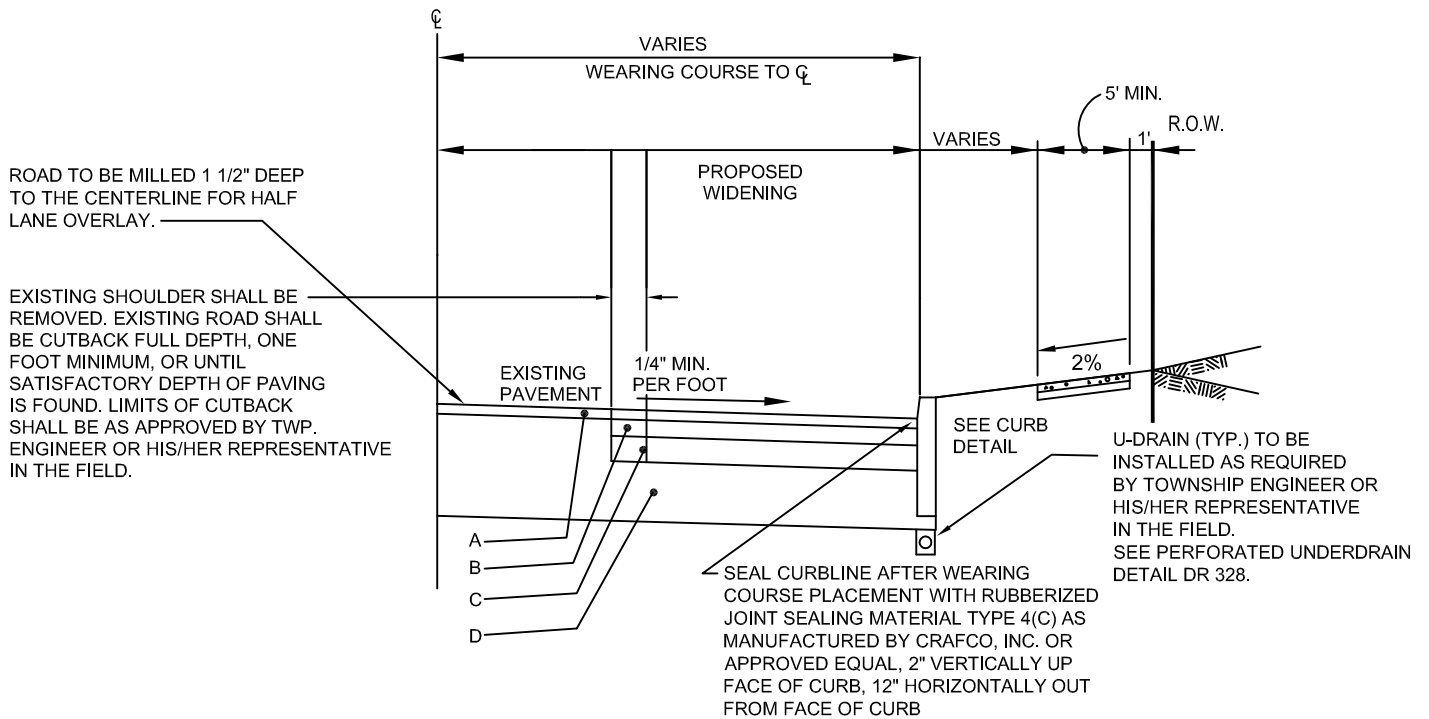

- A. 1 1/2" DEPTH SUPERPAVE ASPHALT MIXTURE DESIGN, HMA WEARING COURSE, PG 64-22, 0.0 TO 0.3 MILLION ESALs, 9.5mm MIX, SRL H
- B. 2" DEPTH SUPERPAVE ASPHALT MIXTURE DESIGN, HMA BINDER COURSE, PG 64-22, 0.0 TO 0.3 MILLION ESALs, 19.0mm MIX.
- C. 3" MIN. DEPTH (OR MATCH EXISTING BASE COURSE DEPTH, WHICHEVER IS GREATER) SUPERPAVE ASPHALT MIXTURE DESIGN, HMA BASE COURSE, PG 64-22, 0.0 TO 0.3 MILLION ESALs, 25.0mm MIX.
- D. 6" 2A STONE

NOTES:

1. PROVIDE MATERIALS AND CONSTRUCTION IN ACCORDANCE WITH THE REQUIREMENTS OF PENNDOT PUBLICATION 408, CURRENT EDITION, INCLUDING BUT NOT LIMITED TO SECTION 210-SUBGRADE, SECTION 350-SUBBASE AND SECTION 409-SUPERPAVE MIXTURE DESIGN, STANDARD AND RPS CONSTRUCTION OF PLANT-MIXED HMA COURSES, AND AS MODIFIED HEREIN.
2. PRIOR TO APPLICATION OF ANY BITUMINOUS PAVING COURSES, PAINT ALL VERTICAL SURFACES OF CURBS, INLETS, MANHOLES, GUTTERS AND OTHER STRUCTURES TO COME IN CONTACT WITH BITUMINOUS MIXTURES WITH A UNIFORM COATING OF BITUMINOUS MATERIAL PER PENNDOT PUBLICATION 408 SECTION 401.3(g) CURRENT EDITION.
3. SEAL ALL PAVING JOINTS AFTER WEARING COURSE PLACEMENT WITH RUBBERIZED JOINT SEALING MATERIAL TYPE 4 (c) AS MANUFACTURED BY CRAFCO, INC. OR APPROVED EQUAL. MINIMUM JOINT SEAL WIDTH = 12" ALONG CURBLINE AND 3" FOR PAVING JOINTS.

SUBGRADE STABILITY VERIFICATION

After contractor has prepared subgrade in accordance with PennDot Publication 408, Section 210 (subgrade) a subgrade stability verification is required prior to placement of sub-base material. A triaxle fully loaded maximum load (quarry slip of loaded weight will be required in the field) is required to run over entire roadway subgrade (including curb lines), over all trenches and anywhere directed by Township Engineer or his/her representatives in the field. Areas displaying pronounced elasticity, pumping, movement or deformation under the loaded triaxle will be noted and marked in the field. The areas noted and/or marked showing unstable subgrade must be corrected and reverified for required stability prior to starting subbase construction. All areas that are to be filled, stoned, paved and/or curbed are required to be proofrolled by this method. A subgrade stability re-verification is required after any/all rain events, snow events (once cleared and/or melted), introduction of moisture to the subgrade or sub-base, or as determined by the Township Engineer's representative in the field.

**UPPER DUBLIN TOWNSHIP STANDARD DETAIL
WIDENING OF RESIDENTIAL ROADS**



DATE 10-2013

NOT TO SCALE

RD104

ROAD TO BE MILLED 1 1/2" DEEP TO THE CENTERLINE FOR HALF LANE OVERLAY.

EXISTING SHOULDER SHALL BE REMOVED. EXISTING ROAD SHALL BE CUTBACK FULL DEPTH, ONE FOOT MINIMUM, OR UNTIL SATISFACTORY DEPTH OF PAVING IS FOUND. LIMITS OF CUTBACK SHALL BE AS APPROVED BY TWP. ENGINEER OR HIS/HER REPRESENTATIVE IN THE FIELD.

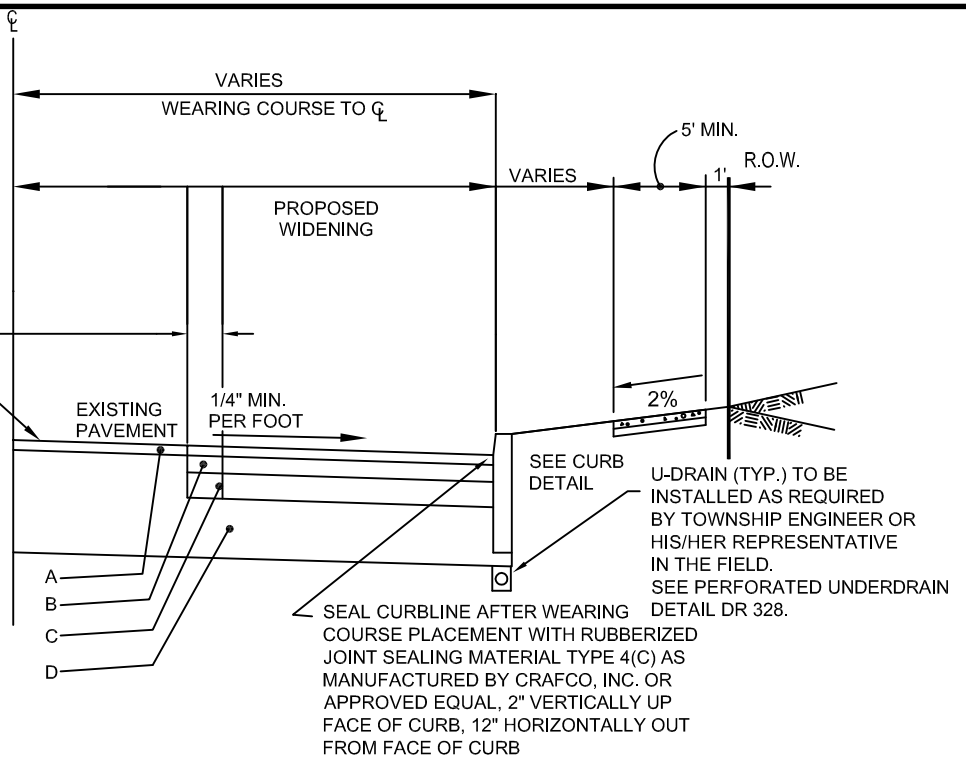

- A. 1 1/2" DEPTH SUPERPAVE ASPHALT MIXTURE DESIGN, HMA WEARING COURSE, PG 64-22, 0.3 TO 3.0 MILLION ESALs, 9.5mm MIX, SRL H
- B. 2" DEPTH SUPERPAVE ASPHALT MIXTURE DESIGN, HMA BINDER COURSE, PG 64-22, 0.3 TO 3.0 MILLION ESALs, 19.0mm MIX.
- C. 4" MIN. DEPTH (OR MATCH EXISTING BASE COURSE DEPTH, WHICHEVER IS GREATER) SUPERPAVE ASPHALT MIXTURE DESIGN, HMA BASE COURSE, PG 64-22, 0.3 TO 3.0 MILLION ESALs, 25.0mm MIX.
- D. 6" 2A STONE

NOTES:

1. PROVIDE MATERIALS AND CONSTRUCTION IN ACCORDANCE WITH THE REQUIREMENTS OF PENNDOT PUBLICATION 408, CURRENT EDITION, INCLUDING BUT NOT LIMITED TO SECTION 210-SUBGRADE, SECTION 350-SUBBASE AND SECTION 409-SUPERPAVE MIXTURE DESIGN, STANDARD AND RPS CONSTRUCTION OF PLANT-MIXED HMA COURSES, AND AS MODIFIED HEREIN.
2. PRIOR TO APPLICATION OF ANY BITUMINOUS PAVING COURSES, PAINT ALL VERTICAL SURFACES OF CURBS, INLETS, MANHOLES, GUTTERS AND OTHER STRUCTURES TO COME IN CONTACT WITH BITUMINOUS MIXTURES WITH A UNIFORM COATING OF BITUMINOUS MATERIAL PER PENNDOT PUBLICATION 408 SECTION 401.3(g) CURRENT EDITION.
3. SEAL ALL PAVING JOINTS AFTER WEARING COURSE PLACEMENT WITH RUBBERIZED JOINT SEALING MATERIAL TYPE 4 (c) AS MANUFACTURED BY CRAFCO, INC. OR APPROVED EQUAL. MINIMUM JOINT SEAL WIDTH = 12" ALONG CURBLINE AND 3" FOR PAVING JOINTS.

SUBGRADE STABILITY VERIFICATION

After contractor has prepared subgrade in accordance with PennDot Publication 408, Section 210 (subgrade) a subgrade stability verification is required prior to placement of sub-base material. A triaxle fully loaded maximum load (quarry slip of loaded weight will be required in the field) is required to run over entire roadway subgrade (including curb lines), over all trenches and anywhere directed by Township Engineer or his/her representatives in the field. Areas displaying pronounced elasticity, pumping, movement or deformation under the loaded triaxle will be noted and marked in the field. The areas noted and/or marked showing unstable subgrade must be corrected and reverified for required stability prior to starting subbase construction. All areas that are to be filled, stoned, paved and/or curbed are required to be proofrolled by this method. A subgrade stability re-verification is required after any/all rain events, snow events (once cleared and/or melted), introduction of moisture to the subgrade or sub-base, or as determined by the Township Engineer's representative in the field.

**UPPER DUBLIN TOWNSHIP STANDARD DETAIL
WIDENING OF SECONDARY ROADS**



DATE 10-2013

NOT TO SCALE

RD105

ROAD TO BE MILLED 1 1/2" DEEP TO THE CENTERLINE FOR HALF LANE OVERLAY.

EXISTING SHOULDER SHALL BE REMOVED. EXISTING ROAD SHALL BE CUTBACK FULL DEPTH, ONE FOOT MINIMUM, OR UNTIL SATISFACTORY DEPTH OF PAVING IS FOUND. LIMITS OF CUTBACK SHALL BE AS APPROVED BY TWP. ENGINEER OR HIS/HER REPRESENTATIVE IN THE FIELD.

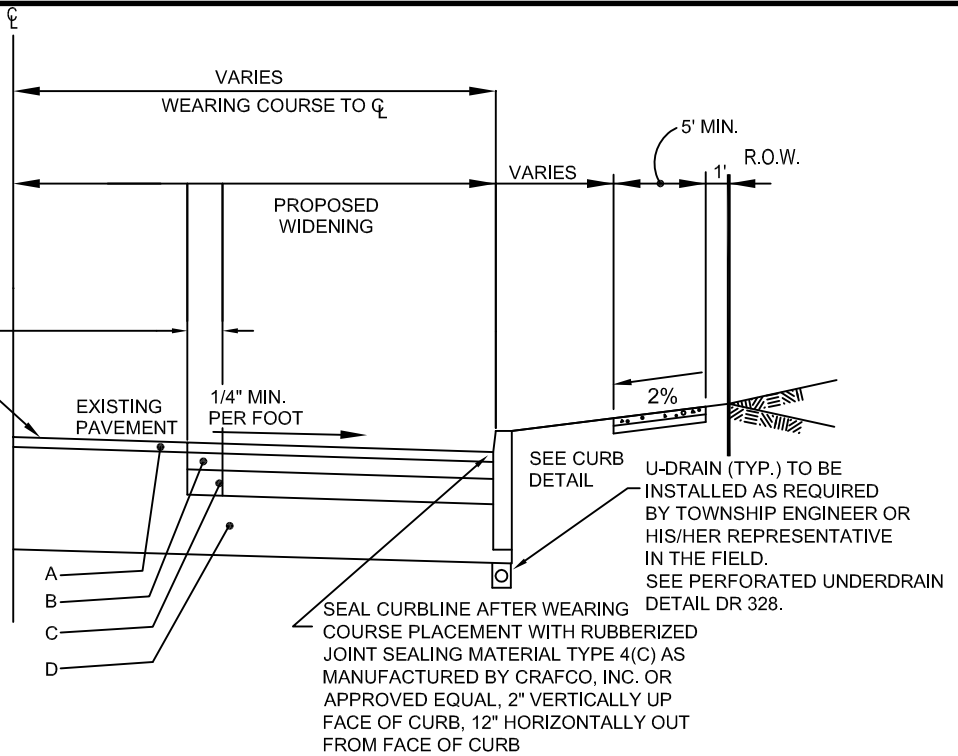

- A. 1 1/2" DEPTH SUPERPAVE ASPHALT MIXTURE DESIGN, HMA WEARING COURSE, PG 64-22, 0.3 TO 3.0 MILLION ESALs, 9.5mm MIX, SRL H
- B. 2" DEPTH SUPERPAVE ASPHALT MIXTURE DESIGN, HMA BINDER COURSE, PG 64-22, 0.3 TO 3.0 MILLION ESALs, 19.0mm MIX.
- C. 6" MIN. DEPTH (OR MATCH EXISTING BASE COURSE DEPTH, WHICHEVER IS GREATER) SUPERPAVE ASPHALT MIXTURE DESIGN, HMA BASE COURSE, PG 64-22, 0.3 TO 3.0 MILLION ESALs, 25.0mm MIX.
- D. 6" 2A STONE

NOTES:

1. PROVIDE MATERIALS AND CONSTRUCTION IN ACCORDANCE WITH THE REQUIREMENTS OF PENNDOT PUBLICATION 408, CURRENT EDITION, INCLUDING BUT NOT LIMITED TO SECTION 210-SUBGRADE, SECTION 350-SUBBASE AND SECTION 409-SUPERPAVE MIXTURE DESIGN, STANDARD AND RPS CONSTRUCTION OF PLANT-MIXED HMA COURSES, AND AS MODIFIED HEREIN.
2. PRIOR TO APPLICATION OF ANY BITUMINOUS PAVING COURSES, PAINT ALL VERTICAL SURFACES OF CURBS, INLETS, MANHOLES, GUTTERS AND OTHER STRUCTURES TO COME IN CONTACT WITH BITUMINOUS MIXTURES WITH A UNIFORM COATING OF BITUMINOUS MATERIAL PER PENNDOT PUBLICATION 408 SECTION 401.3(g) CURRENT EDITION.
3. SEAL ALL PAVING JOINTS AFTER WEARING COURSE PLACEMENT WITH RUBBERIZED JOINT SEALING MATERIAL TYPE 4 (c) AS MANUFACTURED BY CRAFCO, INC. OR APPROVED EQUAL. MINIMUM JOINT SEAL WIDTH = 12" ALONG CURBLINE AND 3" FOR PAVING JOINTS.

SUBGRADE STABILITY VERIFICATION

After contractor has prepared subgrade in accordance with PennDot Publication 408, Section 210 (subgrade) a subgrade stability verification is required prior to placement of sub-base material. A triaxle fully loaded maximum load (quarry slip of loaded weight will be required in the field) is required to run over entire roadway subgrade (including curb lines), over all trenches and anywhere directed by Township Engineer or his/her representatives in the field. Areas displaying pronounced elasticity, pumping, movement or deformation under the loaded triaxle will be noted and marked in the field. The areas noted and/or marked showing unstable subgrade must be corrected and reverified for required stability prior to starting subbase construction. All areas that are to be filled, stoned, paved and/or curbed are required to be proofrolled by this method. A subgrade stability re-verification is required after any/all rain events, snow events (once cleared and/or melted), introduction of moisture to the subgrade or sub-base, or as determined by the Township Engineer's representative in the field.

**UPPER DUBLIN TOWNSHIP STANDARD DETAIL
WIDENING OF PRIMARY ROADS**



DATE 10-2013

NOT TO SCALE

RD106

ROAD TO BE MILLED 1 1/2" DEEP TO THE CENTERLINE FOR HALF LANE OVERLAY.

EXISTING SHOULDER SHALL BE REMOVED. EXISTING ROAD SHALL BE CUTBACK FULL DEPTH, ONE FOOT MINIMUM, OR UNTIL SATISFACTORY DEPTH OF PAVING IS FOUND. LIMITS OF CUTBACK SHALL BE AS APPROVED BY TWP. ENGINEER OR HIS/HER REPRESENTATIVE IN THE FIELD.

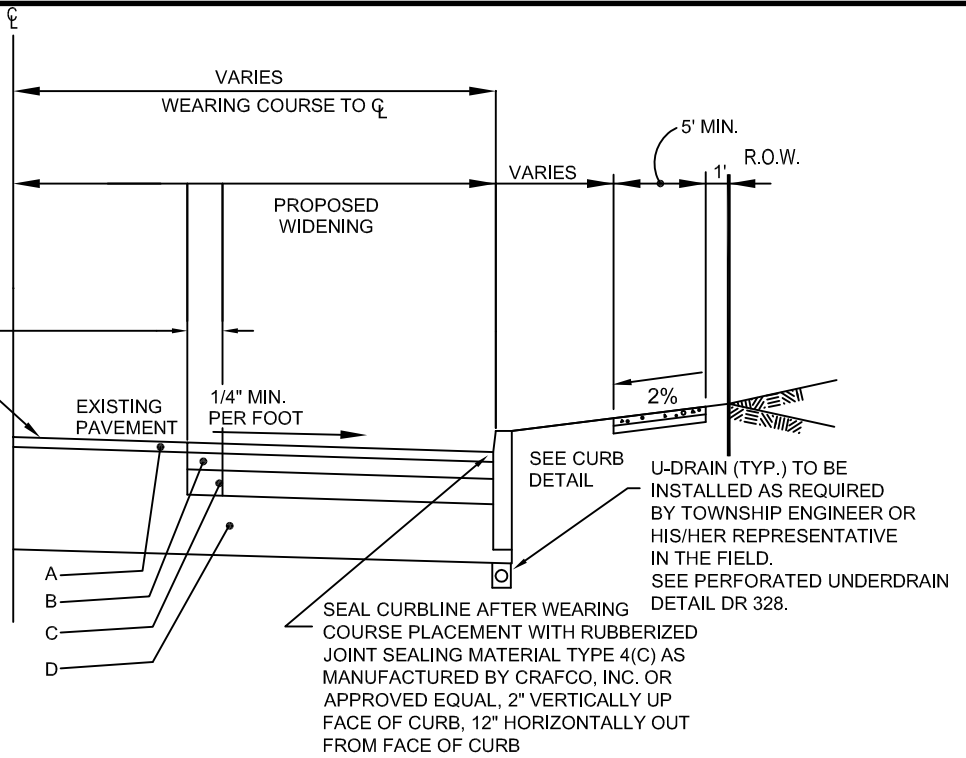

- A. 1 1/2" DEPTH SUPERPAVE ASPHALT MIXTURE DESIGN, HMA WEARING COURSE, PG 64-22, 3.0 TO 30.0 MILLION ESALs, 9.5mm MIX, SRL H
- B. 2" DEPTH SUPERPAVE ASPHALT MIXTURE DESIGN, HMA BINDER COURSE, PG 64-22, 3.0 TO 30.0 MILLION ESALs, 19.0mm MIX.
- C. 8" MIN. DEPTH (OR MATCH EXISTING BASE COURSE DEPTH, WHICHEVER IS GREATER) SUPERPAVE ASPHALT MIXTURE DESIGN, HMA BASE COURSE, PG 64-22, 3.0 TO 30.0 MILLION ESALs, 25.0mm MIX.
- D. 6" 2A STONE

NOTES:

1. PROVIDE MATERIALS AND CONSTRUCTION IN ACCORDANCE WITH THE REQUIREMENTS OF PENNDOT PUBLICATION 408, CURRENT EDITION, INCLUDING BUT NOT LIMITED TO SECTION 210-SUBGRADE, SECTION 350-SUBBASE AND SECTION 409-SUPERPAVE MIXTURE DESIGN, STANDARD AND RPS CONSTRUCTION OF PLANT-MIXED HMA COURSES, AND AS MODIFIED HEREIN.
2. PRIOR TO APPLICATION OF ANY BITUMINOUS PAVING COURSES, PAINT ALL VERTICAL SURFACES OF CURBS, INLETS, MANHOLES, GUTTERS AND OTHER STRUCTURES TO COME IN CONTACT WITH BITUMINOUS MIXTURES WITH A UNIFORM COATING OF BITUMINOUS MATERIAL PER PENNDOT PUBLICATION 408 SECTION 401.3(g) CURRENT EDITION.
3. SEAL ALL PAVING JOINTS AFTER WEARING COURSE PLACEMENT WITH RUBBERIZED JOINT SEALING MATERIAL TYPE 4 (c) AS MANUFACTURED BY CRAFCO, INC. OR APPROVED EQUAL. MINIMUM JOINT SEAL WIDTH = 12" ALONG CURBLINE AND 3" FOR PAVING JOINTS.

SUBGRADE STABILITY VERIFICATION

After contractor has prepared subgrade in accordance with PennDot Publication 408, Section 210 (subgrade) a subgrade stability verification is required prior to placement of sub-base material. A triaxle fully loaded maximum load (quarry slip of loaded weight will be required in the field) is required to run over entire roadway subgrade (including curb lines), over all trenches and anywhere directed by Township Engineer or his/her representatives in the field. Areas displaying pronounced elasticity, pumping, movement or deformation under the loaded triaxle will be noted and marked in the field. The areas noted and/or marked showing unstable subgrade must be corrected and reverified for required stability prior to starting subbase construction. All areas that are to be filled, stoned, paved and/or curbed are required to be proofrolled by this method. A subgrade stability re-verification is required after any/all rain events, snow events (once cleared and/or melted), introduction of moisture to the subgrade or sub-base, or as determined by the Township Engineer's representative in the field.

**UPPER DUBLIN TOWNSHIP STANDARD DETAIL
WIDENING OF ARTERIAL ROADS**



DATE 10-2013

NOT TO SCALE

RD107

(A) 2" DEPTH SUPERPAVE ASPHALT MIXTURE DESIGN,
HMA BINDER COURSE, PG 64-22, 0.0 TO 0.3 MILLION
ESALs, 19 mm MIX. (COMPACTED PER PENNDOT 408
CURRENT EDITION, SECT. 409)

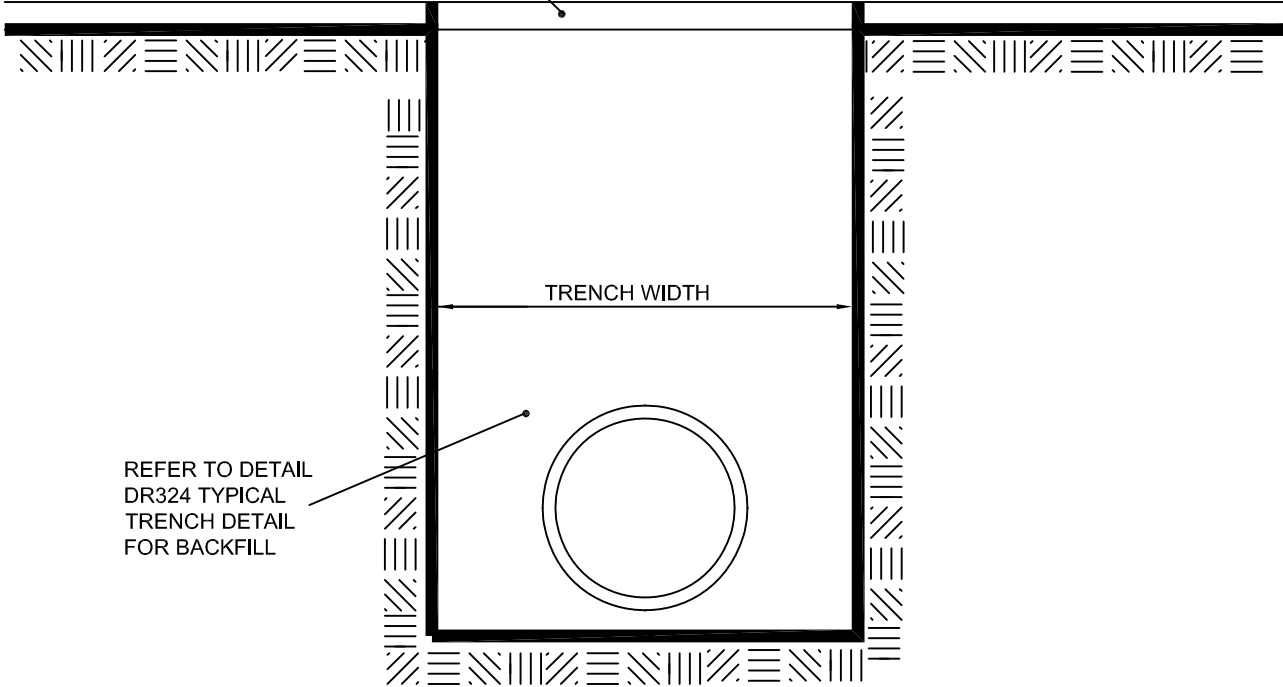

REFER TO DETAIL
DR324 TYPICAL
TRENCH DETAIL
FOR BACKFILL

TRENCH WIDTH

UPPER DUBLIN TOWNSHIP STANDARD DETAIL
TEMPORARY ROAD RESTORATION WITHIN TOWNSHIP ROADS

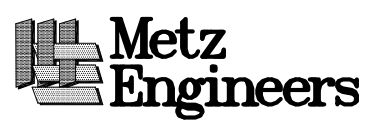

DATE

10-2013

NOT TO SCALE

RD108

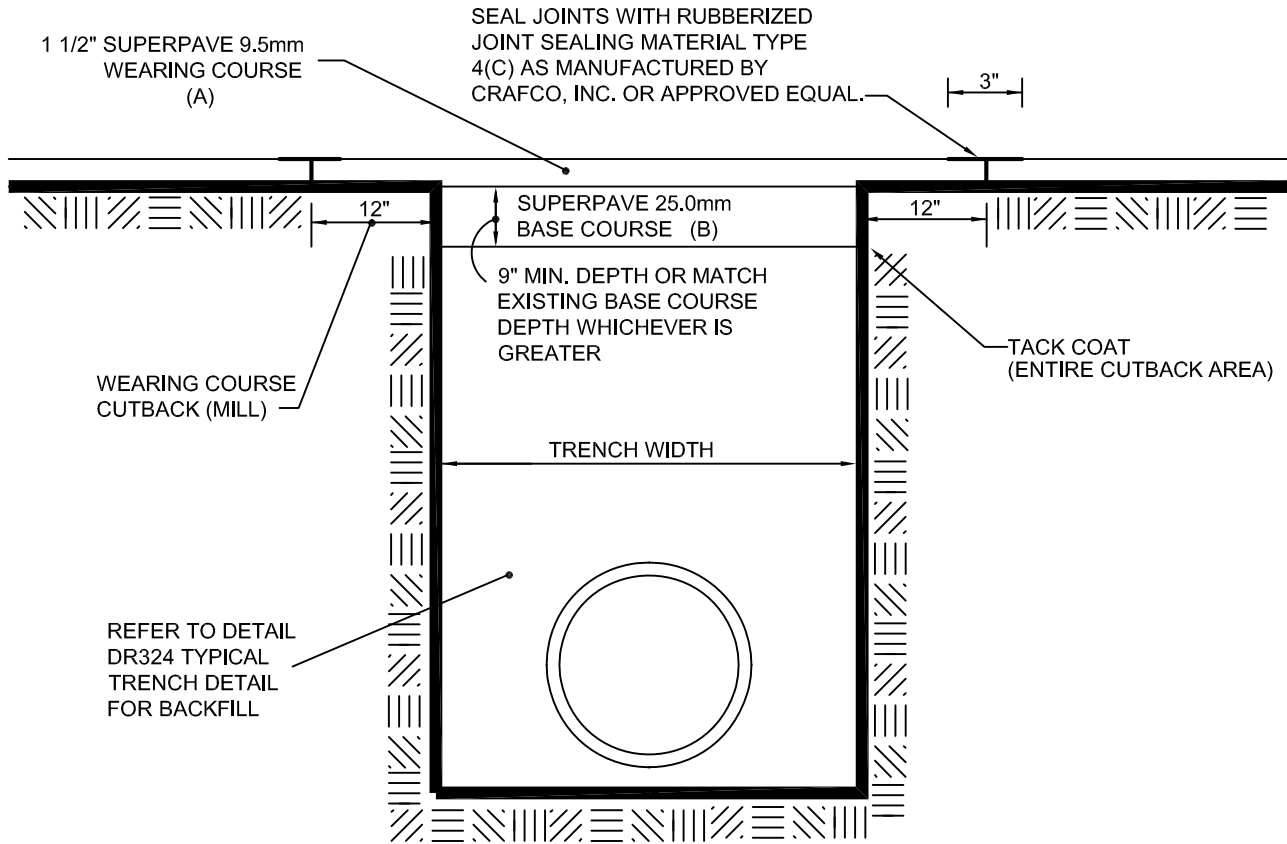

NOTES:

1. PROVIDE MATERIALS AND CONSTRUCTION IN ACCORDANCE WITH THE REQUIREMENTS OF PENNDOT PUBLICATION 408, CURRENT EDITION, INCLUDING BUT NOT LIMITED TO SECTION 210-SUBGRADE, SECTION 350-SUBBASE AND SECTION 409-SUPERPAVE MIXTURE DESIGN, STANDARD AND RPS CONSTRUCTION OF PLANT-MIXED HMA COURSES, AND AS MODIFIED HEREIN.

- (A) 1 1/2" DEPTH SUPERPAVE ASPHALT MIXTURE DESIGN, HMA WEARING COURSE, PG 64-22, 0.0 TO 0.3 MILLION ESALs, 9.5mm MIX, SRL H
- (B) 9" MINIMUM DEPTH (OR MATCH EXISTING BASE COURSE, WHICHEVER IS GREATER) SUPERPAVE ASPHALT MIXTURE DESIGN, HMA BASE COURSE, PG 64-22, 0.0 TO 0.3 ESALs, 25.0mm MIX.

UPPER DUBLIN TOWNSHIP STANDARD DETAIL
PERMANENT ROAD RESTORATION WITHIN TOWNSHIP ROADS



DATE 10-2013

NOT TO SCALE

RD109

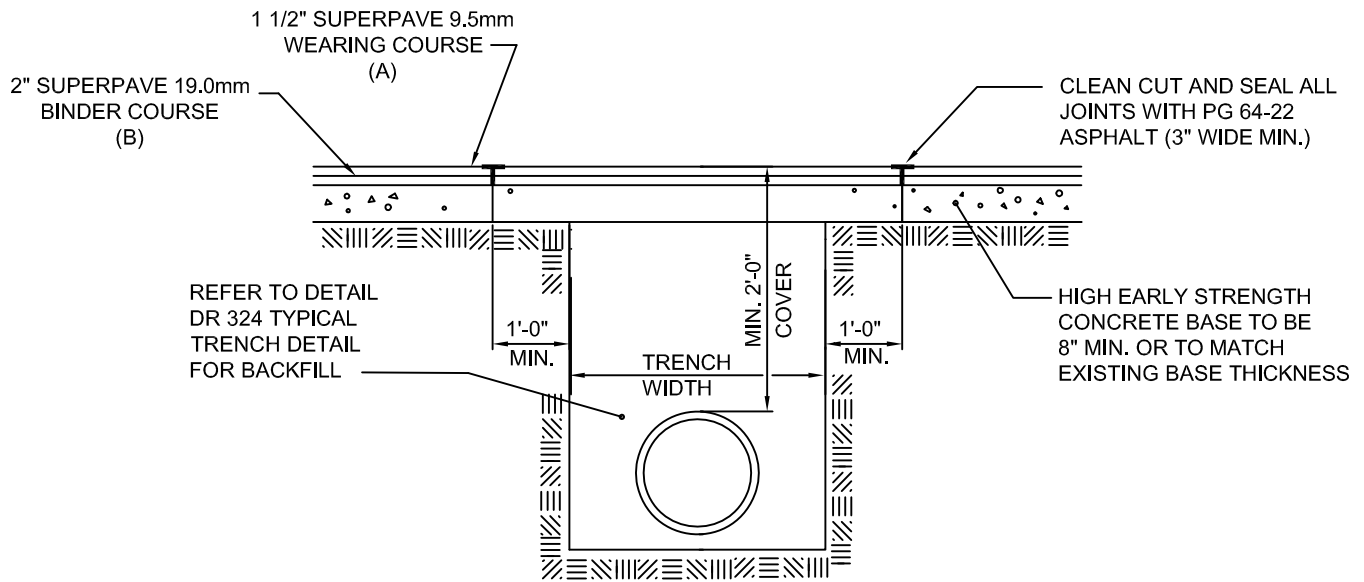

CONCRETE BASE COURSE

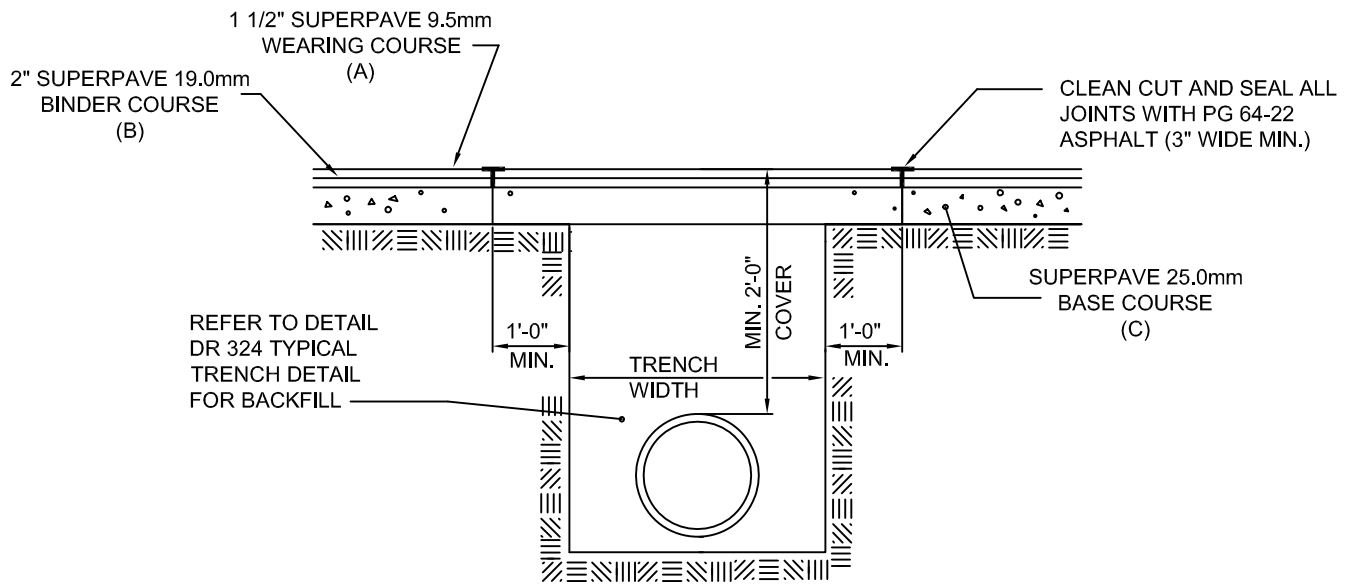

SUPERPAVE BASE COURSE

NOTES:

1. PROVIDE MATERIALS AND CONSTRUCTION IN ACCORDANCE WITH THE REQUIREMENTS OF PENNDOT PUBLICATION 408, CURRENT EDITION, INCLUDING BUT NOT LIMITED TO SECTION 409-SUPERPAVE MIXTURE DESIGN, STANDARD AND RPS CONSTRUCTION OF PLANT-MIXED HMA COURSES, AND AS MODIFIED HEREIN.
2. IF THE ADT IS NOT KNOWN CONTACT THE PENNDOT MAINTENANCE MANAGER FOR THE ROAD RATING.
3. TACK COAT ALL CUTBACK EDGES OR MILLED AREAS PRIOR TO INSTALLING PAVING COURSES.

- (A) 1 1/2" DEPTH SUPERPAVE ASPHALT MIXTURE DESIGN, HMA WEARING COURSE, PG 64-22, 3.0 TO 30.0 MILLION ESALs, 9.5mm MIX, SRL H
- (B) 2" DEPTH SUPERPAVE ASPHALT MIXTURE DESIGN, HMA BINDER COURSE, PG 64-22, 3.0 TO 30.0 MILLION ESALs, 19.0mm MIX.
- (C) 7" MINIMUM DEPTH (OR MATCH EXISTING BASE COURSE DEPTH WHICHEVER IS GREATER) SUPERPAVE ASPHALT MIXTURE DESIGN, HMA BASE COURSE, PG 64-22, 3.0 TO 30.0 MILLION ESALs, 25.0mm MIX.

UPPER DUBLIN TOWNSHIP STANDARD DETAIL
STATE HIGHWAY PERMANENT
RESTORATION DETAILS



DATE 10-2013

NOT TO SCALE

RD110

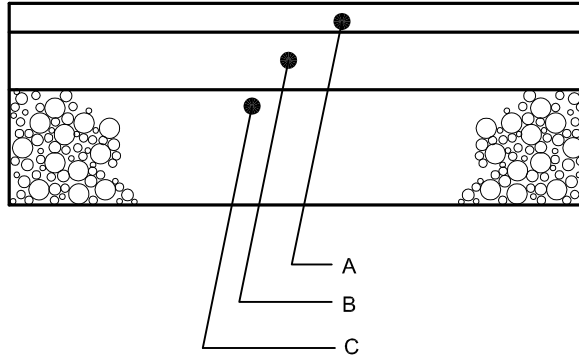

SINGLE FAMILY RESIDENTIAL:

- A. 1 1/2" DEPTH SUPERPAVE ASPHALT MIXTURE DESIGN, HMA WEARING COURSE, PG 64-22, 0.0 TO 0.3 MILLION ESALs, 9.5mm MIX, SRL H
- B. 2" DEPTH SUPERPAVE ASPHALT MIXTURE DESIGN, HMA BINDER COURSE, PG 64-22, 0.0 TO 0.3 MILLION ESALs, 19.0mm MIX.
- C. 8" 2A STONE

NOTES:

1. PROVIDE MATERIALS AND CONSTRUCTION IN ACCORDANCE WITH THE REQUIREMENTS OF PENNDOT PUBLICATION 408, CURRENT EDITION, INCLUDING BUT NOT LIMITED TO SECTION 210-SUBGRADE, SECTION 350-SUBBASE AND SECTION 409-SUPERPAVE MIXTURE DESIGN, STANDARD AND RPS CONSTRUCTION OF PLANT-MIXED HMA COURSES, AND AS MODIFIED HEREIN.

SUBGRADE STABILITY VERIFICATION

After contractor has prepared subgrade in accordance with PennDot Publication 408, Section 210 (subgrade) a subgrade stability verification is required prior to placement of sub-base material. A triaxle fully loaded maximum load (quarry slip of loaded weight will be required in the field) is required to run over entire roadway subgrade (including curb lines), over all trenches and anywhere directed by Township Engineer or his/her representatives in the field. Areas displaying pronounced elasticity, pumping, movement or deformation under the loaded triaxle will be noted and marked in the field. The areas noted and/or marked showing unstable subgrade must be corrected and reverified for required stability prior to starting subbase construction. All areas that are to be filled, stoned, paved and/or curbed are required to be proofrolled by this method. A subgrade stability re-verification is required after any/all rain events, snow events (once cleared and/or melted), introduction of moisture to the subgrade or sub-base, or as determined by the Township Engineer's representative in the field.

UPPER DUBLIN TOWNSHIP STANDARD DETAIL
SINGLE FAMILY RESIDENTIAL BITUMINOUS DRIVEWAY



DATE 10-2013

NOT TO SCALE

RD111

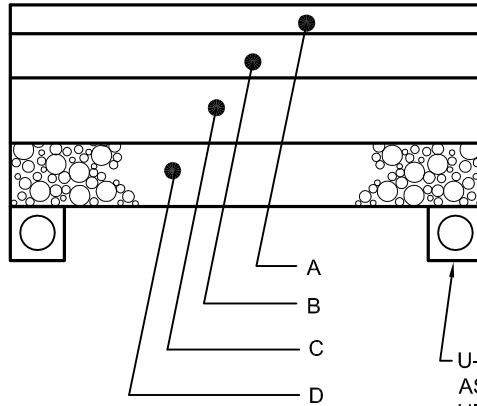

U-DRAIN (TYP.) TO BE INSTALLED AS REQUIRED BY TOWNSHIP OR HIS/HER REPRESENTATIVE IN THE FIELD. SEE PERFORATED UNDERDRAIN DETAIL DR 328.

STANDARD:

- A. 1 1/2" DEPTH SUPERPAVE ASPHALT MIXTURE DESIGN, HMA WEARING COURSE, PG 64-22, 0.0 TO 0.3 MILLION ESALs, 9.5mm MIX, SRL H
- B. 2" DEPTH SUPERPAVE ASPHALT MIXTURE DESIGN, HMA BINDER COURSE, PG 64-22, 0.0 TO 0.3 MILLION ESALs, 19.0mm MIX.
- C. 3" DEPTH SUPERPAVE ASPHALT MIXTURE DESIGN, HMA BASE COURSE, PG 64-22, 0.0 TO 0.3 MILLION ESALs, 25.0mm MIX.
- D. 6" 2A STONE

NOTES:

1. PROVIDE MATERIALS AND CONSTRUCTION IN ACCORDANCE WITH THE REQUIREMENTS OF PENNDOT PUBLICATION 408, CURRENT EDITION, INCLUDING BUT NOT LIMITED TO SECTION 210-SUBGRADE, SECTION 350-SUBBASE AND SECTION 409-SUPERPAVE MIXTURE DESIGN, STANDARD AND RPS CONSTRUCTION OF PLANT-MIXED HMA COURSES, AND AS MODIFIED HEREIN.

SUBGRADE STABILITY VERIFICATION

After contractor has prepared subgrade in accordance with PennDot Publication 408, Section 210 (subgrade) a subgrade stability verification is required prior to placement of sub-base material. A triaxle fully loaded maximum load (quarry slip of loaded weight will be required in the field) is required to run over entire roadway subgrade (including curb lines), over all trenches and anywhere directed by Township Engineer or his/her representatives in the field. Areas displaying pronounced elasticity, pumping, movement or deformation under the loaded triaxle will be noted and marked in the field. The areas noted and/or marked showing unstable subgrade must be corrected and reverified for required stability prior to starting subbase construction. All areas that are to be filled, stoned, paved and/or curbed are required to be proofrolled by this method. A subgrade stability re-verification is required after any/all rain events, snow events (once cleared and/or melted), introduction of moisture to the subgrade or sub-base, or as determined by the Township Engineer's representative in the field.

UPPER DUBLIN TOWNSHIP STANDARD DETAIL
MULTI-FAMILY RESIDENTIAL AND
NON-RESIDENTIAL BITUMINOUS DRIVEWAY & PARKING



DATE 10-2013

NOT TO SCALE

RD112

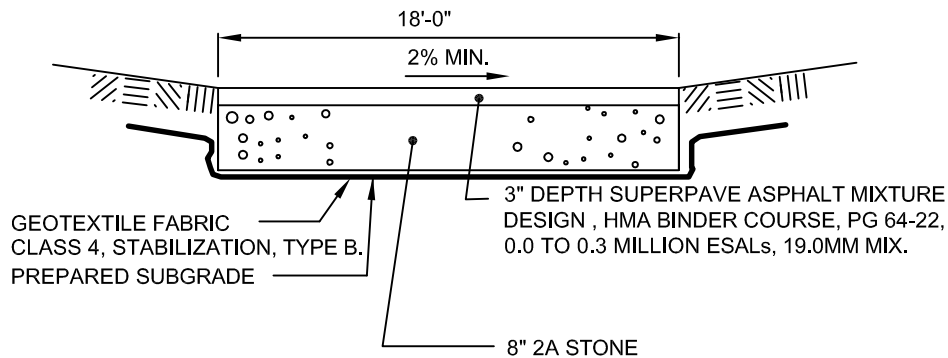

NOTES:

1. IN AREAS WITH CONCRETE CURB, PROVIDE A 20' (MIN.) WIDE DEPRESSION.
2. PROVIDE ADEQUATE SIGNAGE FOR EMERGENCY VEHICLE RECOGNITION.
3. PROVIDE MATERIALS AND CONSTRUCTION IN ACCORDANCE WITH THE REQUIREMENTS OF PENNDOT PUBLICATION 408, CURRENT EDITION, INCLUDING BUT NOT LIMITED TO SECTION 210-SUBGRADE, SECTION 350-SUBBASE AND SECTION 409-SUPERPAVE MIXTURE DESIGN, STANDARD AND RPS CONSTRUCTION OF PLANT-MIXED HMA COURSES, AND AS MODIFIED HEREIN.

SUBGRADE STABILITY VERIFICATION

After contractor has prepared subgrade in accordance with PennDot Publication 408, Section 210 (subgrade) a subgrade stability verification is required prior to placement of sub-base material. A triaxle fully loaded maximum load (quarry slip of loaded weight will be required in the field) is required to run over entire roadway subgrade (including curb lines), over all trenches and anywhere directed by Township Engineer or his/her representatives in the field. Areas displaying pronounced elasticity, pumping, movement or deformation under the loaded triaxle will be noted and marked in the field. The areas noted and/or marked showing unstable subgrade must be corrected and reverified for required stability prior to starting subbase construction. All areas that are to be filled, stoned, paved and/or curbed are required to be proofrolled by this method. A subgrade stability re-verification is required after any/all rain events, snow events (once cleared and/or melted), introduction of moisture to the subgrade or sub-base, or as determined by the Township Engineer's representative in the field.

**UPPER DUBLIN TOWNSHIP STANDARD DETAIL
EMERGENCY ACCESS DETAIL**



DATE 10-2013

NOT TO SCALE

RD113

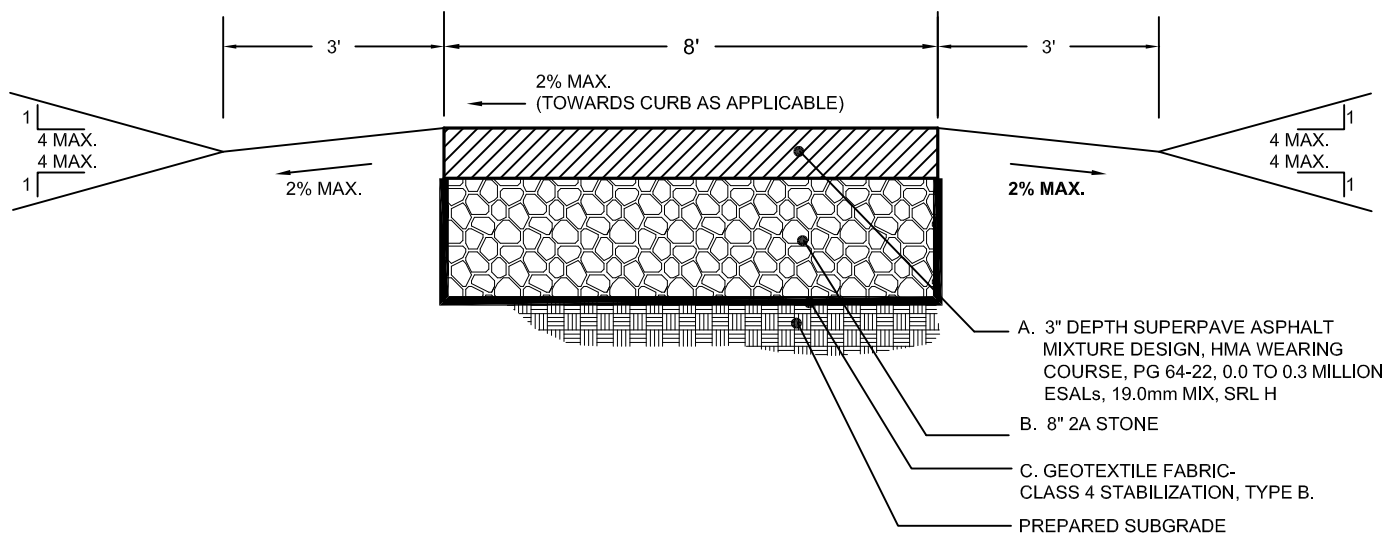

NOTES:

1. PROVIDE MATERIALS AND CONSTRUCTION IN ACCORDANCE WITH THE REQUIREMENTS OF PENNDOT PUBLICATION 408, CURRENT EDITION, INCLUDING BUT NOT LIMITED TO SECTION 210-SUBGRADE, SECTION 350-SUBBASE AND SECTION 409-SUPERPAVE MIXTURE DESIGN, STANDARD AND RPS CONSTRUCTION OF PLANT-MIXED HMA COURSES, AND AS MODIFIED HEREIN.

SUBGRADE STABILITY VERIFICATION

After contractor has prepared subgrade in accordance with PennDot Publication 408, Section 210 (subgrade) a subgrade stability verification is required prior to placement of sub-base material. A triaxle fully loaded maximum load (quarry slip of loaded weight will be required in the field) is required to run over entire roadway subgrade (including curb lines), over all trenches and anywhere directed by Township Engineer or his/her representatives in the field. Areas displaying pronounced elasticity, pumping, movement or deformation under the loaded triaxle will be noted and marked in the field. The areas noted and/or marked showing unstable subgrade must be corrected and reverified for required stability prior to starting subbase construction. All areas that are to be filled, stoned, paved and/or curbed are required to be proofrolled by this method. A subgrade stability re-verification is required after any/all rain events, snow events (once cleared and/or melted), introduction of moisture to the subgrade or sub-base, or as determined by the Township Engineer's representative in the field.

**UPPER DUBLIN TOWNSHIP STANDARD DETAIL
WALKING PATH DETAIL**



DATE 10-2013

NOT TO SCALE

RD114

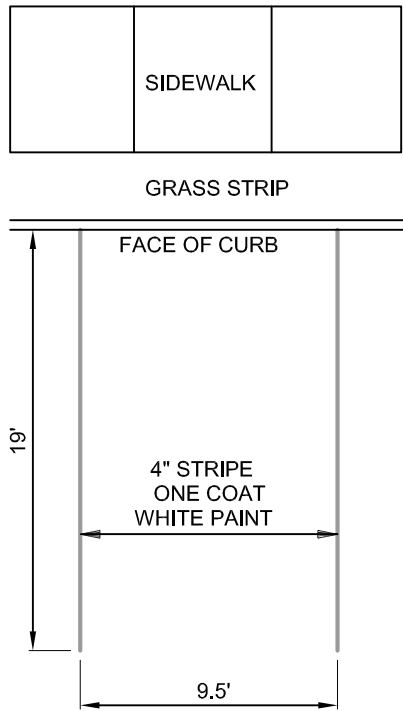

PARKING STALL WITH CURB WITH GRASS STRIP BETWEEN CURB AND SIDEWALK

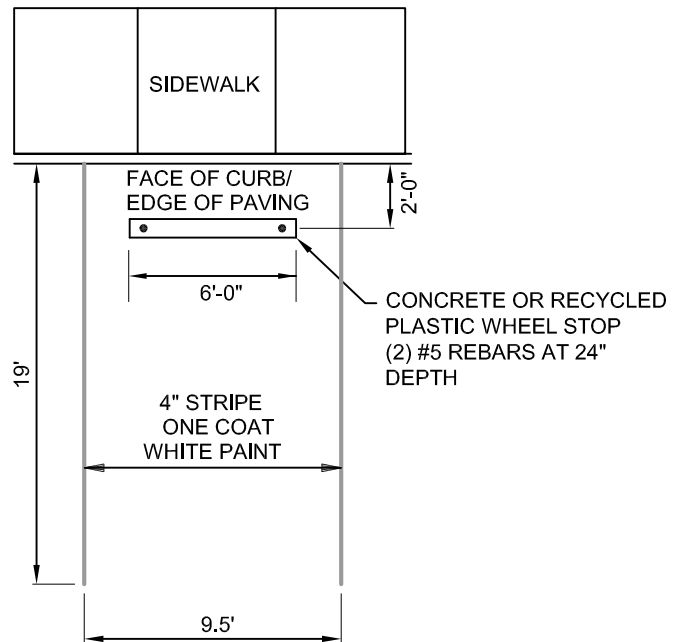

PARKING STALL WITH NO CURB OR WITH CURB AND SIDEWALK WITHOUT A GRASS STRIP

TOTAL PARKING IN LOT	REQUIRED MINIMUM NUMBER OF ACCESSIBLE SPACES
1 TO 25	1
26 TO 50	2
51 TO 75	3
76 TO 100	4
101 TO 150	5
151 TO 200	6
201 TO 300	7
301 TO 400	8
401 TO 500	9
501 TO 1000	2 PERCENT OF TOTAL
1000 AND OVER	20 PLUS 1 FOR EACH 100 OVER 1000

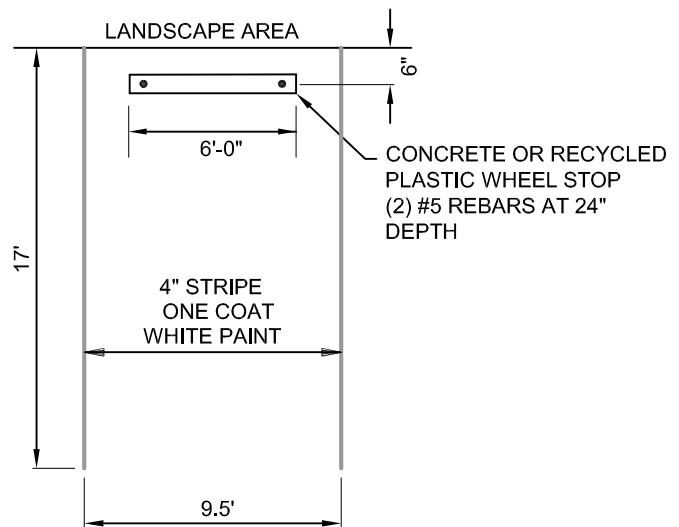

PARKING STALL WITH LANDSCAPE AREA

**UPPER DUBLIN TOWNSHIP STANDARD DETAIL
PARKING SPACE DETAIL**



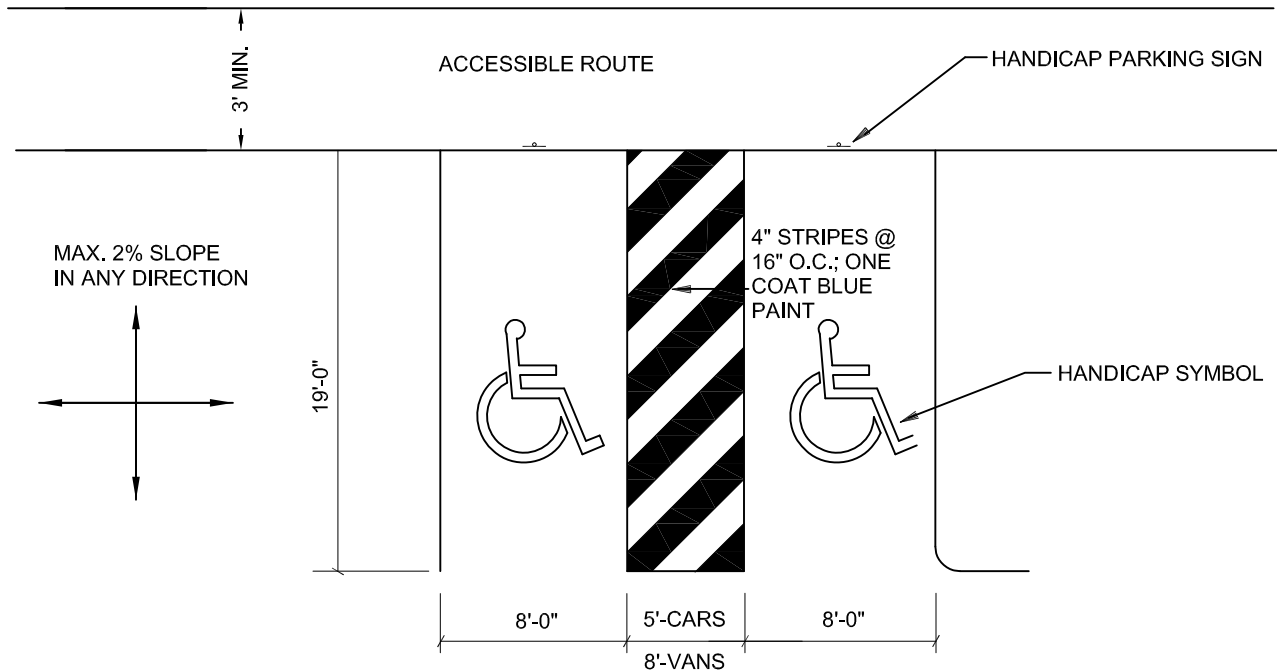

NOTE: HANDICAPPED SPACES SHALL BE PAINTED & SIGNED ACCORDING TO ADA REQUIREMENTS.

TOTAL PARKING IN LOT	REQUIRED MINIMUM NUMBER OF ACCESSIBLE SPACES
1 TO 25	1
26 TO 50	2
51 TO 75	3
76 TO 100	4
101 TO 150	5
151 TO 200	6
201 TO 300	7
301 TO 400	8
401 TO 500	9
501 TO 1000	2 PERCENT OF TOTAL
1000 AND OVER	20 PLUS 1 FOR EACH 100 OVER 1000

UPPER DUBLIN TOWNSHIP STANDARD DETAIL
HANDICAPPED PARKING SPACE DETAIL



DATE 10-2013

NOT TO SCALE

RD116

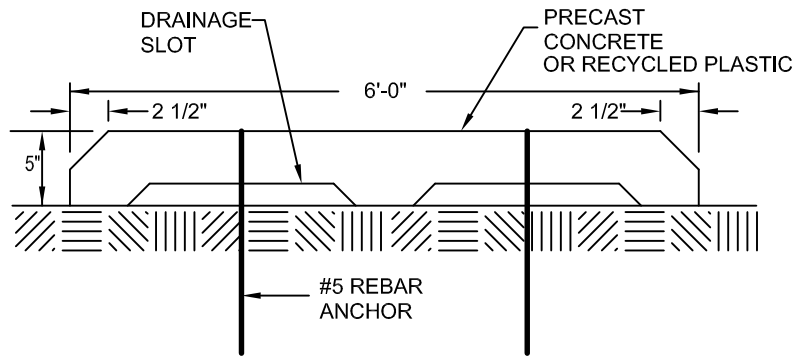
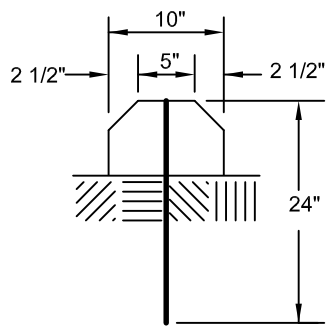

UPPER DUBLIN TOWNSHIP STANDARD DETAIL
WHEEL STOP DETAIL



DATE

10-2013

NOT TO SCALE

RD117

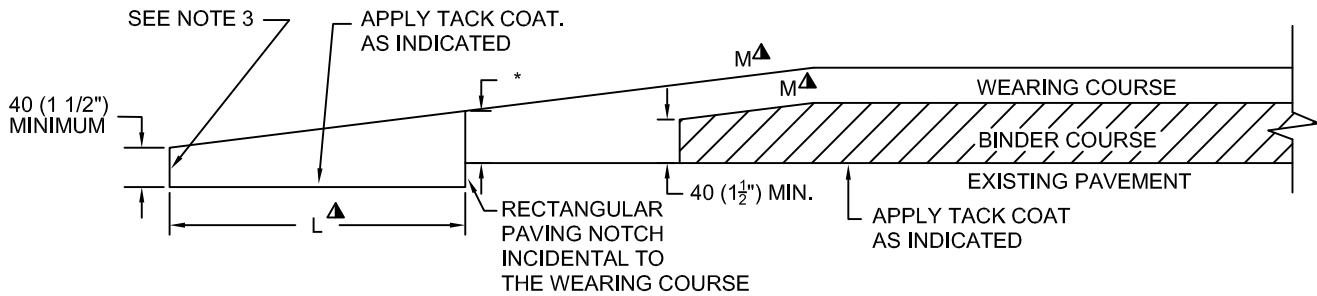

**OVERLAY TRANSITION WITH PAVING NOTCH
ON BITUMINOUS PAVEMENTS**

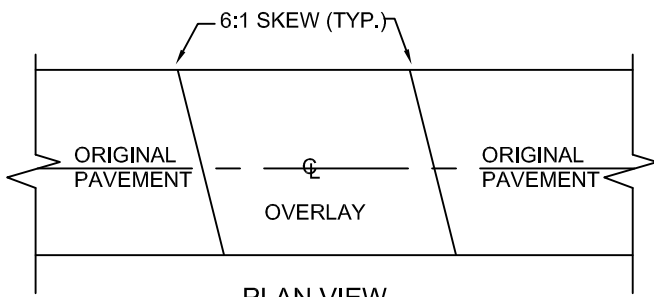

**TANGENT SECTION
TWO-LANE DIRECTIONAL**

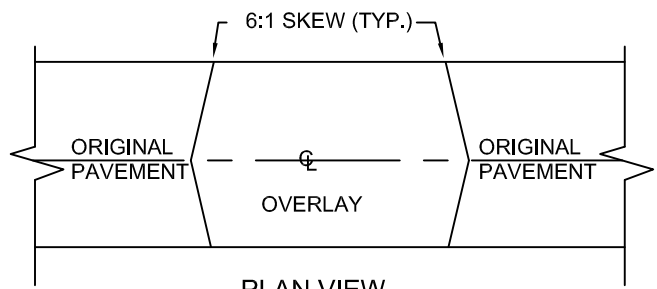

**TANGENT SECTION
TWO-LANE, TWO-WAY TRAFFIC**

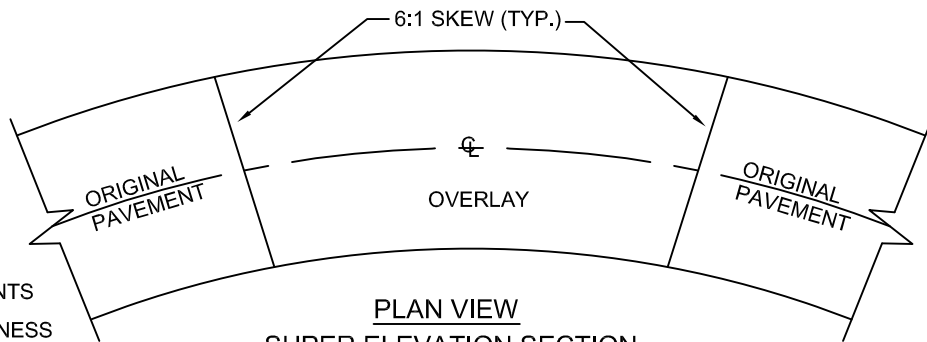

**PLAN VIEW
SUPER ELEVATION SECTION**

▲ SEE TABLE A FOR DIMENSIONAL REQUIREMENTS

* SHOULD EQUAL THE THICKNESS OF THE WEARING COURSE

TABLE A

FUNCTIONAL CLASSIFICATION	SLOPE M (MAXIMUM)	PAVING NOTCH L (MINIMUM)
ARTERIALS > 45 MPH SEE NOTE 2.	0.28% (1" IN 30')	30'
ARTERIALS < 45 MPH SEE NOTE 2.	0.83% (1" IN 10')	10'
COLLECTORS AND LOCAL ROADS	0.83% (1" IN 10')	10'
CROSS STREETS SEE NOTE 1	8.33% (1" IN 12")	1'
DRIVEWAYS	8.33% (1" IN 12")	1'

NOTES:

1. USE HIGHER APPROPRIATE CRITERIA IF A CROSS STREET HAS A FUNCTIONAL CLASSIFICATION OF COLLECTORS AND LOCAL ROADS OR HIGHER.
2. USE 85TH PERCENTILE SPEED, IF AVAILABLE. OTHERWISE, USE THE POSTED SPEED.
3. PLACE EDGE FLUSH WITH EXISTING PAVEMENT AND SEAL AS SPECIFIED IN PUB. 408, CURRENT EDITION SEC. 401.3(j)3.
4. ALL DIMENSIONS ARE IN MILLIMETERS UNLESS OTHERWISE NOTED. U.S. CUSTOMARY UNITS IN () PARENTHESIS.
5. SEAL ALL PAVING JOINTS AFTER WEARING COURSE PLACEMENT WITH RUBBERIZED JOINT SEALING MATERIAL TYPE 4(C) AS MANUFACTURED BY CRAFCO, INC. OR APPROVED EQUAL. MINIMUM JOINT SEAL WIDTH = 12" ALONG CURBLINE AND 3" FOR PAVING JOINTS.

**UPPER DUBLIN TOWNSHIP STANDARD DETAIL
OVERLAY TRANSITION WITH PAVING NOTCH**



DATE 10-2013

NOT TO SCALE

RD118

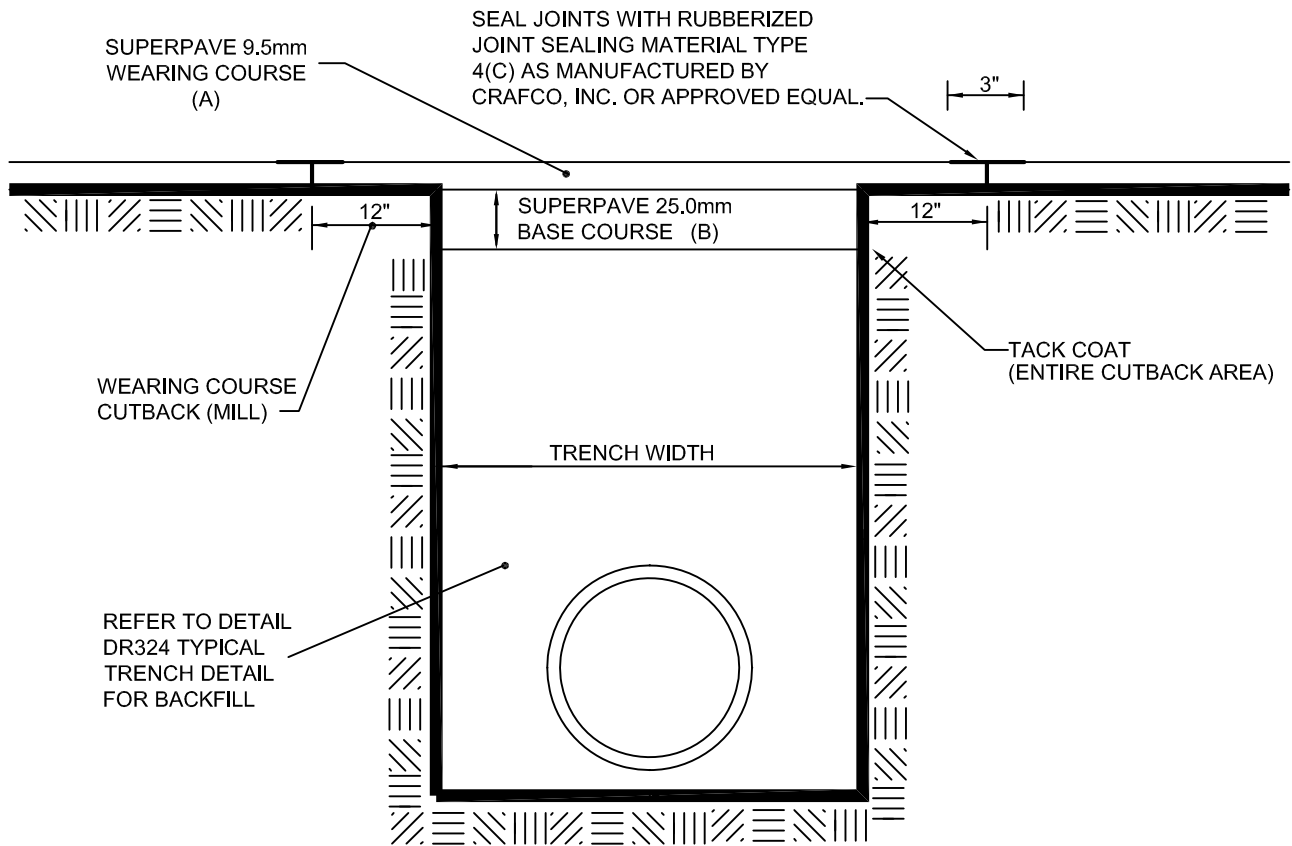

NOTES:

1. PROVIDE MATERIALS AND CONSTRUCTION IN ACCORDANCE WITH THE REQUIREMENTS OF PENNDOT PUBLICATION 408, CURRENT EDITION, INCLUDING BUT NOT LIMITED TO SECTION 210-SUBGRADE, SECTION 350-SUBBASE AND SECTION 409-SUPERPAVE MIXTURE DESIGN, STANDARD AND RPS CONSTRUCTION OF PLANT-MIXED HMA COURSES, AND AS MODIFIED HEREIN.

SINGLE FAMILY RESIDENTIAL

- (A) 1 1/2" DEPTH SUPERPAVE ASPHALT MIXTURE DESIGN, HMA WEARING COURSE, PG 64-22, 0.0 TO 0.3 MILLION ESALs, 9.5mm MIX, SRL H
- (B) 4" MINIMUM DEPTH (OR MATCH EXISTING BASE COURSE, WHICHEVER IS GREATER) SUPERPAVE ASPHALT MIXTURE DESIGN, HMA BASE COURSE, PG 64-22, 0.0 TO 0.3 ESALs, 25.0mm MIX.

MULTI-FAMILY RESIDENTIAL AND NON-RESIDENTIAL

- (A) 1 1/2" DEPTH SUPERPAVE ASPHALT MIXTURE DESIGN, HMA WEARING COURSE, PG 64-22, 0.0 TO 0.3 MILLION ESALs, 9.5mm MIX, SRL H
- (B) 7" MINIMUM DEPTH (OR MATCH EXISTING BASE COURSE, WHICHEVER IS GREATER) SUPERPAVE ASPHALT MIXTURE DESIGN, HMA BASE COURSE, PG 64-22, 0.0 TO 0.3 ESALs, 25.0mm MIX.

UPPER DUBLIN TOWNSHIP STANDARD DETAIL
PERMANENT DRIVEWAY AND PARKING LOT RESTORATION



DATE 10-2013

NOT TO SCALE

RD119

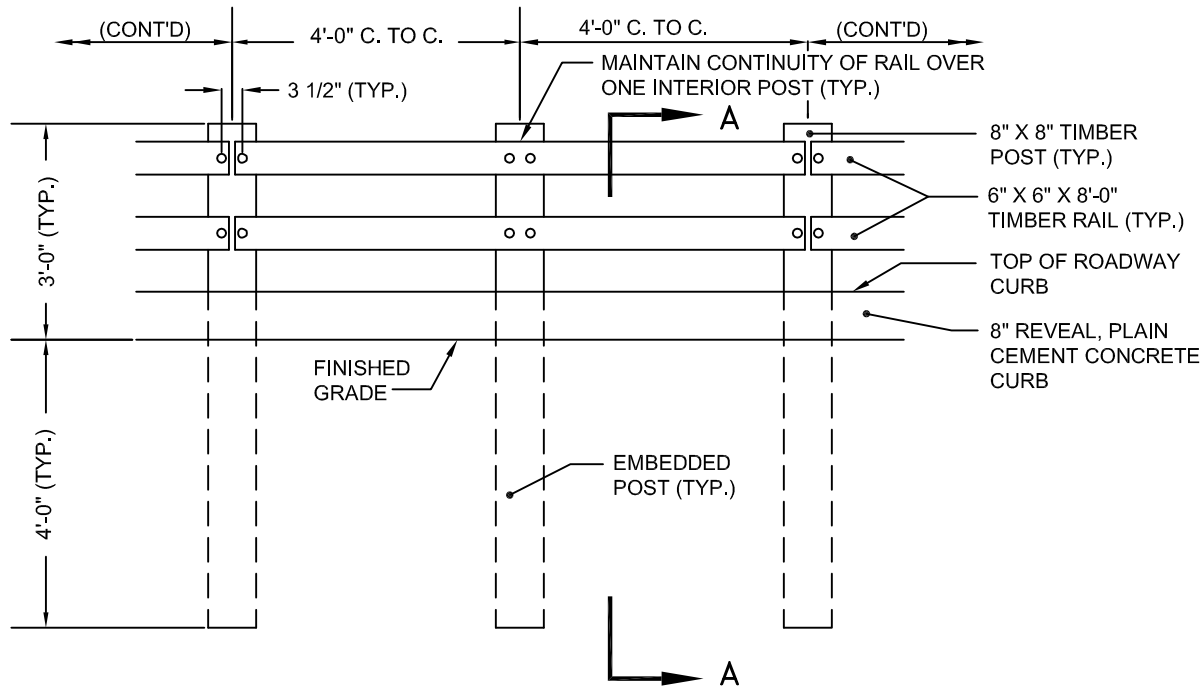

TYPICAL GUIDE RAIL ELEVATION

2 - 7/8" DIA. GRADE 5 GALV. STEEL CARRIAGE BOLTS, NUTS, AND WASHERS REQUIRED, AT EACH CONNECTION TO POST. (4 TOTAL PER POST)(TYP.) BOLTS TO BE 12" LONG.

6" X 6" TIMBER RAILS CONTINUOUS OVER ONE INTERIOR POST (TYP.) SEE TYPICAL GUIDE RAIL ELEVATION FOR BOLT LOCATIONS

PROVIDE A RECTANGULAR GROOVE CUT (DADO), IN ALL POSTS, 1 1/2" DEEP BY THE WIDTH OF THE RAIL TO ATTACH RAILS TO POSTS.

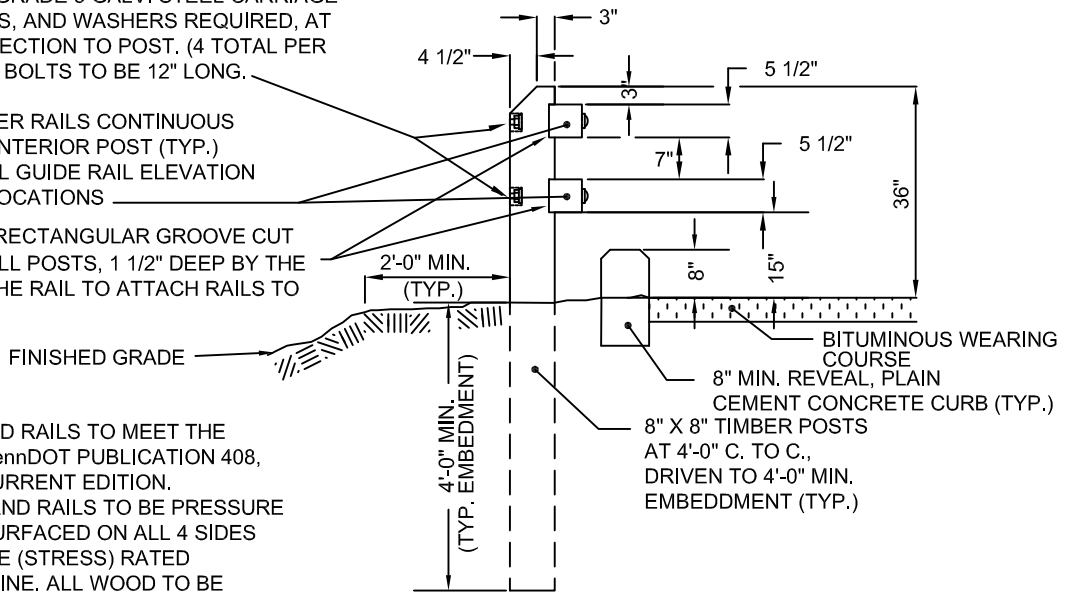

SECTION A-A

NOTES:

1. WOODEN POSTS AND RAILS TO MEET THE REQUIREMENTS OF PennDOT PUBLICATION 408, SECTION 1109.03(c) CURRENT EDITION.
2. ALL WOOD POSTS AND RAILS TO BE PRESSURE TREATED, SMOOTH SURFACED ON ALL 4 SIDES (S4S) AND NO. 1 DENSE (STRESS) RATED SOUTHERN YELLOW PINE. ALL WOOD TO BE CLEARLY IDENTIFIED (STAMPED) WITH THEIR RATING.
3. ALL FASTENERS (CARRIAGE BOLTS) TO BE THROUGH BOLTED AND COUNTER SUNK 1 1/2" DEEP ON BACK SIDE. END OF BOLTS TO BE CUT FLUSH AND GROUND SMOOTH.
4. IF POSTS ARE TO BE MECHANICALLY DRIVEN INTO SOIL, ALL MEASURES MUST BE TAKEN TO PREVENT ANY DAMAGE DONE TO POSTS. IF POSTS ARE TO BE SET IN CONCRETE, CONCRETE SHALL BE 3300 PSI MINIMUM COMPRESSIVE STRENGTH.

UPPER DUBLIN TOWNSHIP STANDARD DETAIL
TIMBER GUIDE RAIL



DATE 10-2013

NOT TO SCALE

RD120

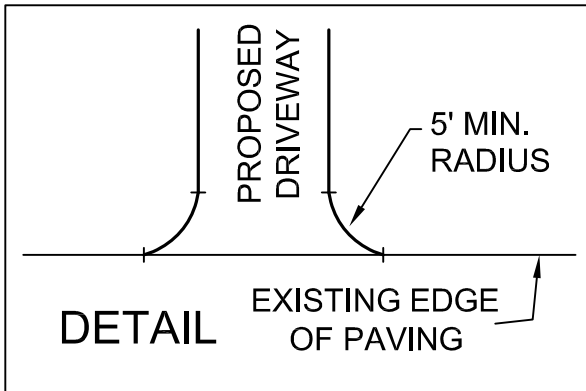
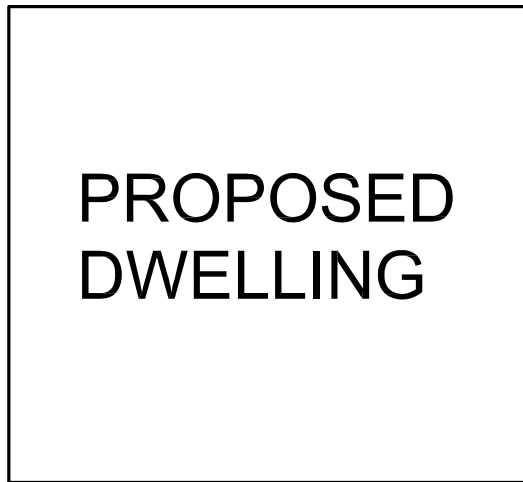

10' MIN. (SINGLE FAMILY)
12' MIN. (MULTI FAMILY)

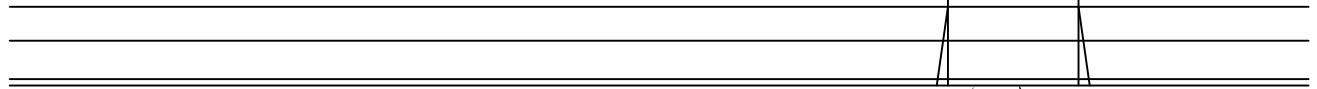

NOTES:

1. MULTI FAMILY DRIVEWAYS SERVE MORE THAN ONE RESIDENCE.
2. IN THE EVENT OF A SUBDIVISION OR ROAD IMPROVEMENT IN THE AREA OF AN EXISTING UNPAVED DRIVEWAY, THE DRIVEWAY MUST BE PAVED FOR A DISTANCE OF 20' BEHIND THE SIDEWALK (OR CURB IF SIDEWALK IS NOT EXISTING OR REQUIRED).

SEE DETAIL FOR UNCURBED ROAD

REFER TO UPPER DUBLIN TOWNSHIP STANDARD DETAIL CC204 CONCRETE CURB DETAIL FOR CURB AND CURB DEPRESSION REQUIREMENTS.

**UPPER DUBLIN TOWNSHIP STANDARD DETAIL
TYPICAL DRIVEWAY DETAIL**



DATE 10-2013

NOT TO SCALE

RD121

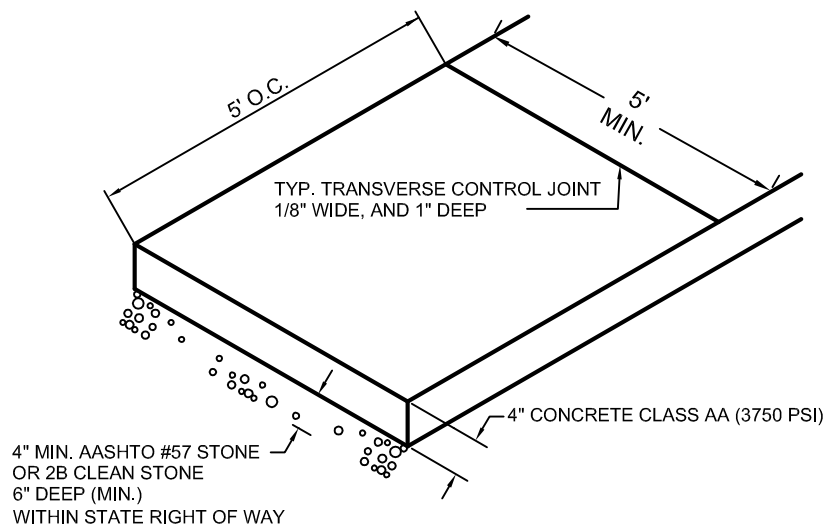
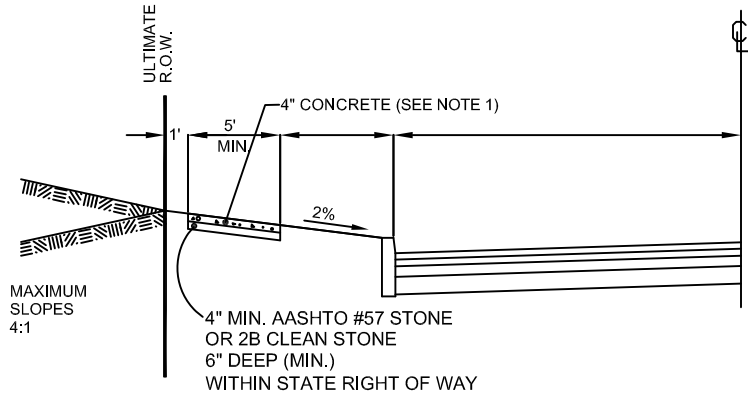

NOTES:

1. PROVIDE MATERIALS AND CONSTRUCTION IN ACCORDANCE WITH THE REQUIREMENTS OF PENNDOT PUBLICATION 408, CURRENT EDITION, AND AS MODIFIED HEREIN.
2. CONCRETE SHALL BE CLASS AA (3750 PSI), AIR ENTRAINED (6%) WITH A 4" SLUMP MAX.
3. TRANSVERSE CONTROL JOINTS 1/8" WIDE AND 1" DEEP TO BE FORMED EVERY 5 FEET.
4. EXPANSION JOINTS WITH 1/2" PRE-MOLDED MATERIAL SHALL BE PLACED EVERY 30 FEET TO FULL DEPTH.
5. ALL EDGES TO BE ROUNDED WITH A 1/4" TOOL.
6. LIGHT BROOM FINISH TO BE APPLIED.
7. WEATHER PROTECTION SHALL BE USED IN ACCORDANCE WITH PENNDOT PUBLICATION 408 CURRENT EDITION.
8. PENETRATING SEALER TO BE APPLIED IMMEDIATELY FOLLOWING FINISHING OPERATIONS. PENETRATING SEALER TO BE AQUARON CPT2000 OR APPROVED EQUAL.

UPPER DUBLIN TOWNSHIP STANDARD DETAIL
PROPOSED SIDEWALK



DATE 10-2013

NOT TO SCALE

CC200

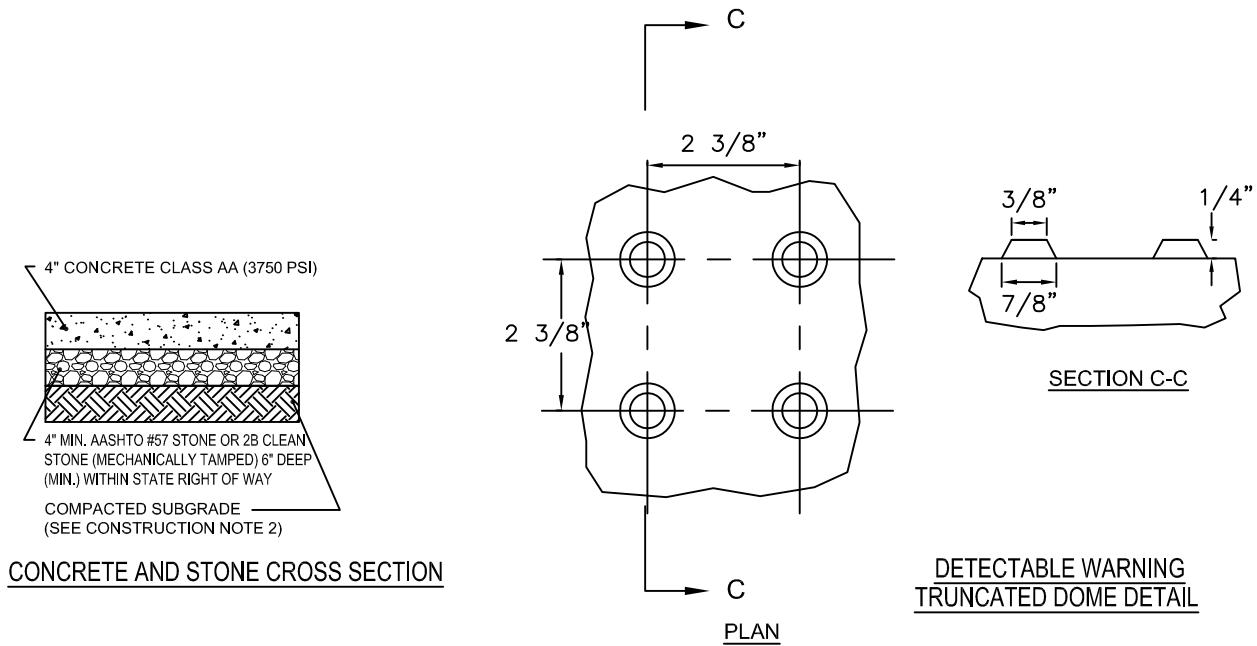

DESIGN NOTES

1. EACH CURB RAMP REQUIRES AN INDIVIDUAL DESIGN, BY THE DESIGN ENGINEER. EACH INDIVIDUAL RAMP MAY REQUIRE COMPLETED DISTRICT (D6) CS-4401 INSPECTION FORMS. DESIGN MUST SHOW ALL ELEVATIONS, SLOPES ETC. AND MUST COMPLY WITH PENNDOTS ADA REFERENCE GUIDE (DISTRICT 6) AND PENNDOT RC 67m CURRENT EDITION. REFER TO CONSTRUCTION NOTES FOR CONSTRUCTION REQUIREMENTS.
2. REFER TO PENNDOT RC 67m CURRENT EDITION FOR TYPES OF RAMPS.

CONSTRUCTION NOTES:

1. PROVIDE MATERIALS AND CONSTRUCTION IN ACCORDANCE WITH THE REQUIREMENTS OF PENNDOT PUBLICATION 408, CURRENT EDITION, AND AS MODIFIED HEREIN.
2. SUBGRADE MUST BE APPROVED BY THE TOWNSHIP ENGINEER OR THE TOWNSHIP ENGINEERS REPRESENTATIVE IN THE FIELD PRIOR TO INSTALLING STONE.
3. CONCRETE SHALL BE 4" THICK (MIN.) CLASS AA (3750 PSI), AIR ENTRAINED (6%) WITH A 4" SLUMP (MAX).
4. TRANSVERSE CONTROL JOINTS 1/8" WIDE AND 1" DEEP AT THE DISCRETION OF TOWNSHIP ENGINEER OR HIS/HER REPRESENTATIVE IN FIELD.
5. CONCRETE TO BE PLACED ON A 4"(MIN.) LAYER OF AASHTO #57 STONE OR 2B CLEAN STONE (6" MIN. LAYER WITHIN STATE R/W).
6. ALL EDGES TO BE ROUNDED WITH A 1/4" TOOL.
7. FINISH CEMENT CONCRETE RAMP WITH COARSE BROOMED TEXTURE TRANSVERSE TO THE SLOPE OF CURB RAMP.
8. WEATHER PROTECTION SHALL BE USED IN ACCORDANCE WITH PENNDOT PUBLICATION 408 CURRENT EDITION.
9. PENETRATING SEALER TO BE APPLIED IMMEDIATELY FOLLOWING FINISHING OPERATIONS. PENETRATING SEALER TO BE AQUORON CPT2000 OR APPROVED EQUAL.
10. ALIGN DETECTABLE WARNING DOMES ON A SQUARE GRID IN THE PREDOMINANT DIRECTION OF TRAVEL TO PERMIT WHEELS TO ROLL BETWEEN DOMES.
11. PROVIDE "CAST IN PLACE TRUNCATED DOME DETECTABLE WARNING SYSTEM " AS MANUFACTURED BY ADA SOLUTIONS, INC. OR APPROVED EQUAL. COLOR: BRICK RED.

**UPPER DUBLIN TOWNSHIP STANDARD DETAIL
CURB AND SIDEWALK RAMPS**



DATE 10-2013

NOT TO SCALE

CC201

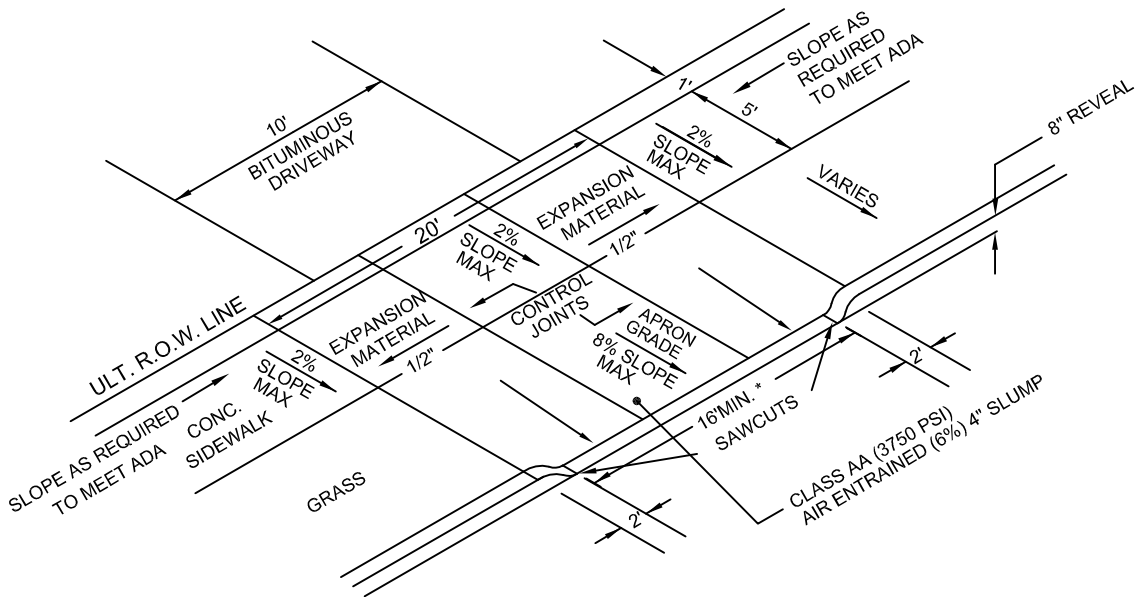

DESIGN NOTES

1. EACH APRON REQUIRES AN INDIVIDUAL DESIGN, BY THE DESIGN ENGINEER. EACH INDIVIDUAL APRON DESIGN MUST SHOW ALL ELEVATIONS, SLOPES ETC. AND MUST COMPLY WITH THE DRIVEWAY DETAILS SECTION OF PENNDOTS ADA REFERENCE GUIDE (DISTRICT 6) AND PENNDOT RC 67m CURRENT EDITION. REFER TO CONSTRUCTION NOTES FOR CONSTRUCTION REQUIREMENTS.
2. REFER TO PENNDOT RC 67m CURRENT EDITION FOR TYPES OF DRIVEWAY APRONS.

* 16' FOR 10' WIDE DRIVEWAYS.
FOR WIDER DRIVEWAYS ADD 6' TO DRIVE WIDTH.

NOTE: CONTROL JOINTS TO BE INSTALLED PER PENNDOT 408 CURRENT EDITION

CONTROL JOINT PLACEMENT TO BE AT THE DISCRETION OF THE TWP. ENGINEER OR THEIR REPRESENTATIVE IN THE FIELD.

CONSTRUCTION NOTES:

1. PROVIDE MATERIALS AND CONSTRUCTION IN ACCORDANCE WITH PENNDOT PUBLICATION 408, CURRENT EDITION AND AS MODIFIED HEREIN.
2. SUBGRADE MUST BE APPROVED BY THE TOWNSHIP ENGINEER OR THE TOWNSHIP ENGINEERS REPRESENTATIVE IN THE FIELD PRIOR TO INSTALLING STONE.
3. WEATHER PROTECTION SHALL BE USED IN ACCORDANCE WITH PENNDOT PUBLICATION 408, CURRENT EDITION.
4. PENETRATING SEALER TO BE APPLIED IMMEDIATELY FOLLOWING FINISHING OPERATIONS. PENETRATING SEALER TO BE AQUORON CPT2000 OR APPROVED EQUAL.

RESIDENTIAL

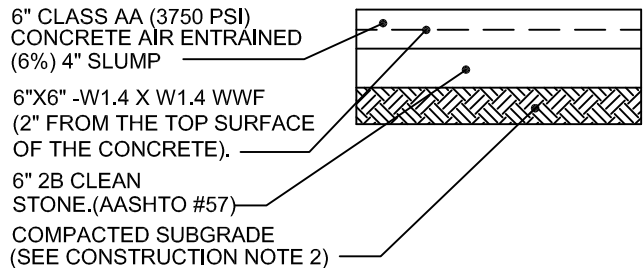

COMMERCIAL OR INDUSTRIAL

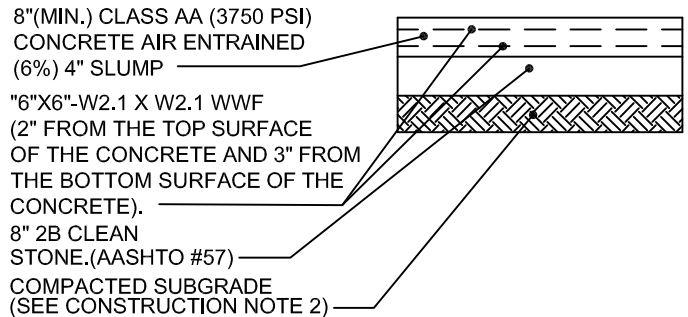

**UPPER DUBLIN TOWNSHIP STANDARD DETAIL
CONCRETE DRIVEWAY APRON**



DATE 10-2013

NOT TO SCALE

CC202

*CURB RAMP DESIGN NOTES

1. EACH CURB RAMP REQUIRES AN INDIVIDUAL DESIGN, BY THE DESIGN ENGINEER. EACH INDIVIDUAL RAMP MAY REQUIRE COMPLETED DISTRICT 6 (D6) CS-4401 INSPECTION FORMS. DESIGN MUST SHOW ALL ELEVATIONS, SLOPES ETC. AND MUST COMPLY WITH PENNDOTS ADA REFERENCE GUIDE (DISTRICT 6) AND PENNDOT RC 67m CURRENT EDITION. REFER TO CONSTRUCTION NOTES FOR CONSTRUCTION REQUIREMENTS.
2. REFER TO PENNDOT RC 67m CURRENT EDITION FOR TYPES OF RAMPS.

DRIVEWAY APRON DESIGN NOTES

1. EACH APRON REQUIRES AN INDIVIDUAL DESIGN, BY THE DESIGN ENGINEER. EACH INDIVIDUAL APRON DESIGN MUST SHOW ALL ELEVATIONS, SLOPES ETC. AND MUST COMPLY WITH THE DRIVEWAY DETAILS SECTION OF PENNDOTS ADA REFERENCE GUIDE (DISTRICT 6) AND PENNDOT RC 67m CURRENT EDITION. REFER TO CONSTRUCTION NOTES FOR CONSTRUCTION REQUIREMENTS.
2. REFER TO PENNDOT RC 67m CURRENT EDITION FOR TYPES OF DRIVEWAY APRONS.

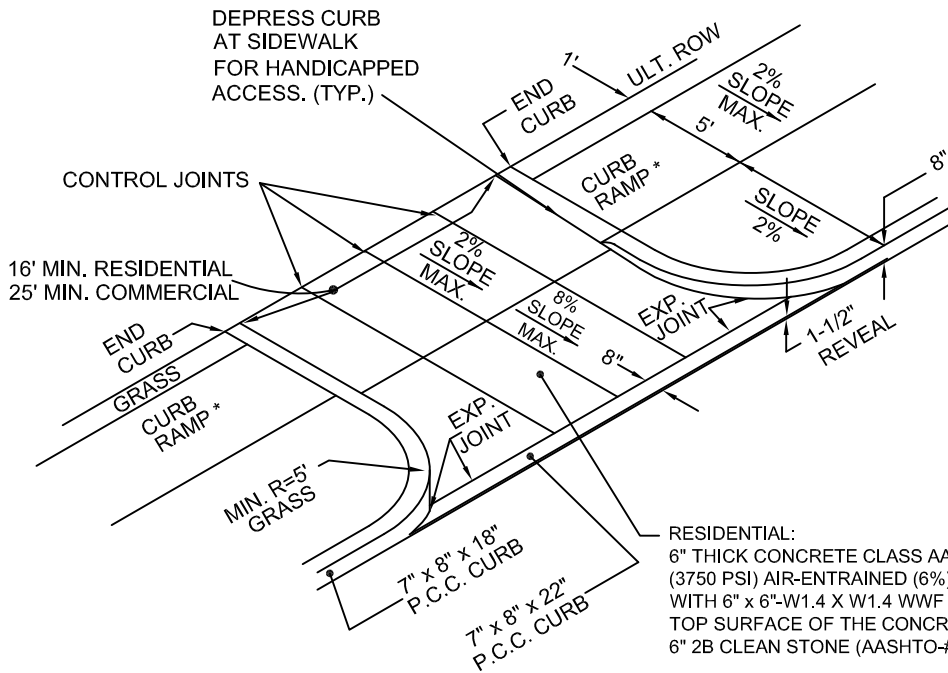

RESIDENTIAL:
 6" THICK CONCRETE CLASS AA
 (3750 PSI) AIR-ENTRAINED (6%), 4" SLUMP)
 WITH 6" x 6"-W1.4 X W1.4 WWF 2" FROM THE
 TOP SURFACE OF THE CONCRETE ON
 6" 2B CLEAN STONE (AASHTO-#57)

COMMERCIAL OR INDUSTRIAL:
 8"(MIN.) THICK CONCRETE CLASS AA (3750 PSI) AIR
 ENTRAINED (6%) 4" SLUMP WITH 6"x6"-W2.1 X W2.1
 WWF. 2" FROM THE TOP SURFACE OF THE CONCRETE
 AND 3" FROM THE BOTTOM SURFACE OF THE
 CONCRETE ON 8" 2B CLEAN STONE (AASHTO #57).

CONSTRUCTION NOTES:

1. PROVIDE MATERIALS AND CONSTRUCTION IN ACCORDANCE WITH THE REQUIREMENTS OF PENNDOT PUBLICATION 408, CURRENT EDITION, AND AS MODIFIED HEREIN.
2. SUBGRADE MUST BE APPROVED BY THE TOWNSHIP ENGINEER OR THE TOWNSHIP ENGINEERS REPRESENTATIVE IN THE FIELD PRIOR TO INSTALLING STONE.
3. WEATHER PROTECTION SHALL BE USED IN ACCORDANCE WITH PENNDOT PUBLICATION 408, CURRENT EDITION.
4. PENETRATING SEALER TO BE APPLIED IMMEDIATELY FOLLOWING FINISHING OPERATIONS. PENETRATING SEALER TO BE AQUORON CPT2000 OR APPROVED EQUAL.

**UPPER DUBLIN TOWNSHIP STANDARD DETAIL
 CONCRETE DRIVEWAY RAMP
 WITH CURBED RADIUS RETURNS**



DATE 10-2013

NOT TO SCALE

CC203

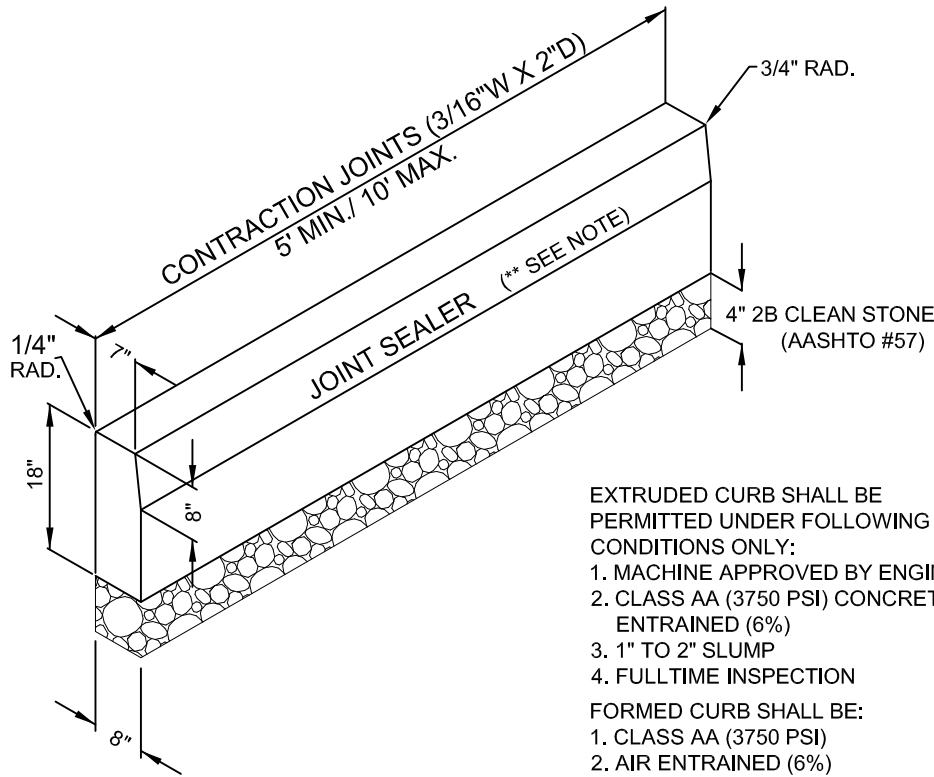

** SEAL CURBLINE AFTER WEARING COURSE PLACEMENT WITH RUBBERIZED JOINT SEALING MATERIAL TYPE 4(C) AS MANUFACTURED BY CRAFTCO, INC. OR APPROVED EQUAL. 2" VERTICALLY UP FACE OF CURB, 12" HORIZONTALLY OUT FROM FACE OF CURB.

EXTRUDED CURB SHALL BE PERMITTED UNDER FOLLOWING CONDITIONS ONLY:

1. MACHINE APPROVED BY ENGINEER
2. CLASS AA (3750 PSI) CONCRETE AIR ENTRAINED (6%)
3. 1" TO 2" SLUMP
4. FULLTIME INSPECTION

FORMED CURB SHALL BE:

1. CLASS AA (3750 PSI)
2. AIR ENTRAINED (6%)
3. 4" SLUMP

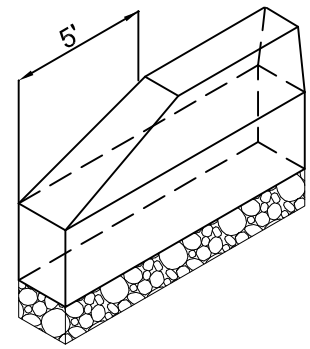
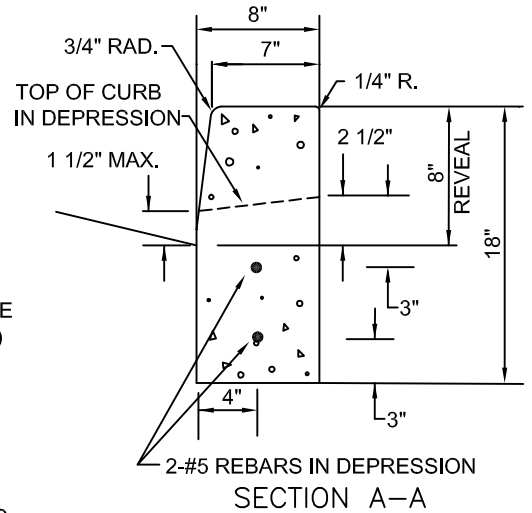

END OF CURB TAPER

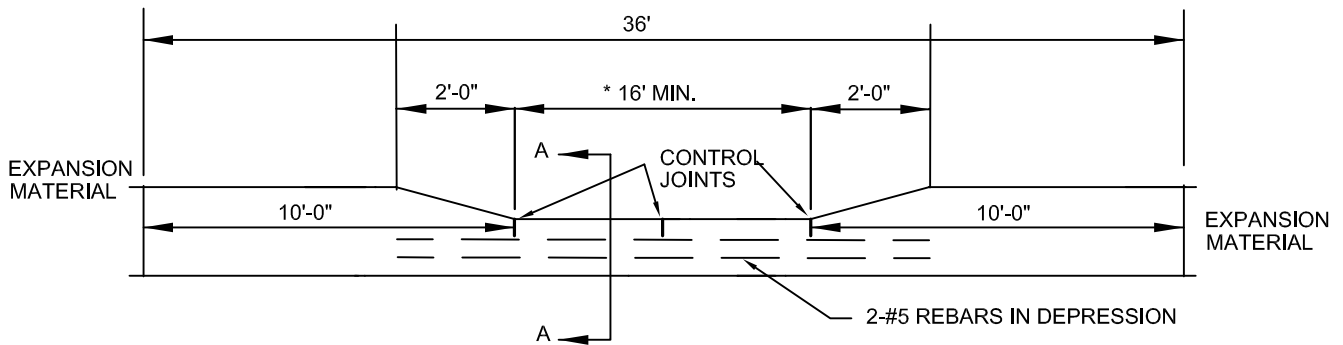

* 16' FOR 10' WIDE DRIVEWAY.
FOR WIDER DRIVEWAYS ADD 6'
TO THE DRIVE WIDTH.

NOTES:

1. PROVIDE MATERIALS AND CONSTRUCTION IN ACCORDANCE WITH THE REQUIREMENTS OF PENNDOT PUBLICATION 408, CURRENT EDITION, AND AS MODIFIED HEREIN.
2. 3/4" PREMOLDED EXPANSION JOINT MATERIAL SHALL BE PLACED AT 30 FOOT MAXIMUM SPACING TO FULL DEPTH OF CURB. (40 FOOT MAXIMUM FOR EXTRUDED CURB), AT STRUCTURES AND AT THE END OF A DAYS WORK.
3. CURB SHALL BE DOWEL PINNED INTO INLETS. 2-#8X1'-0" DOWEL BARS ON BOTH SIDES OF INLET.
4. 4" 2B CLEAN STONE UNDER CURB.
5. WEATHER PROTECTION SHALL BE USED IN ACCORDANCE WITH PENNDOT PUBLICATION 408, CURRENT EDITION.
6. PENETRATING SEALER TO BE APPLIED IMMEDIATELY FOLLOWING FINISHING OPERATIONS. PENETRATING SEALER TO BE AQUORON CPT2000 OR APPROVED EQUAL.

UPPER DUBLIN TOWNSHIP STANDARD DETAIL
CONCRETE CURB DETAIL



DATE 10-2013

NOT TO SCALE

CC204

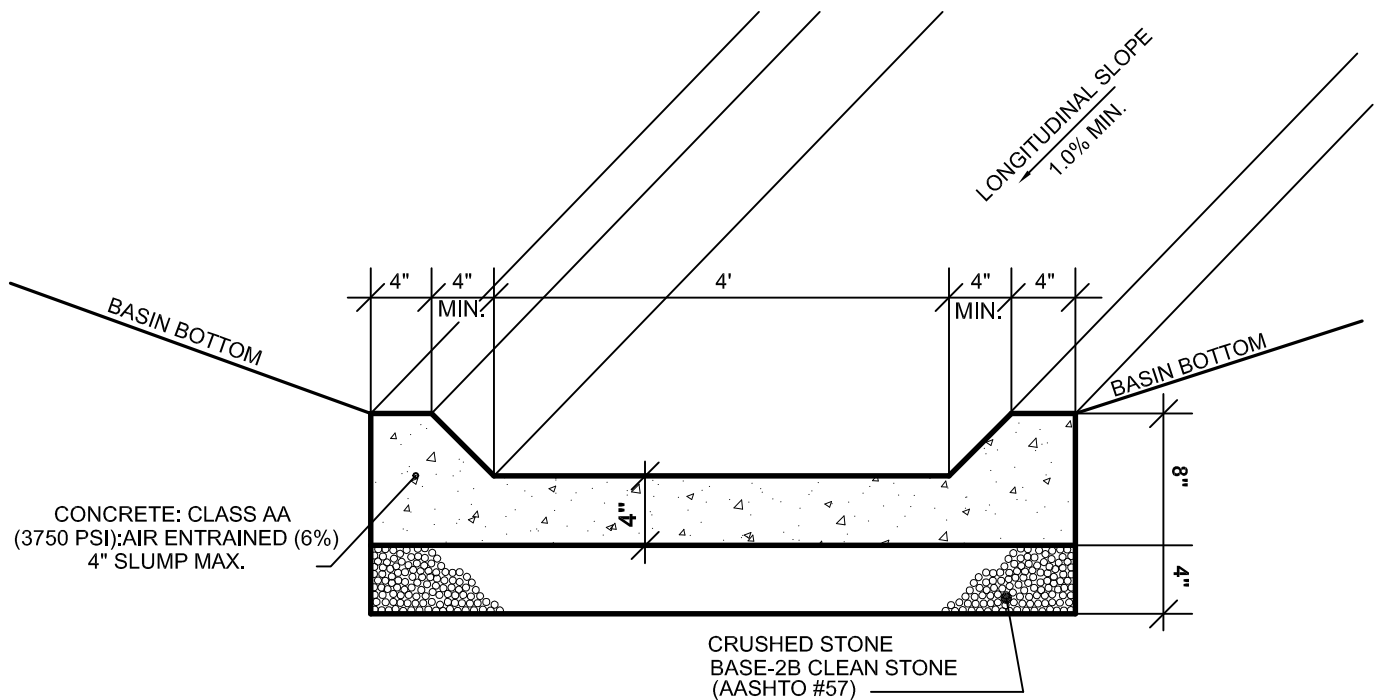

NOTES:

1. PROVIDE MATERIALS AND CONSTRUCTION IN ACCORDANCE WITH THE REQUIREMENTS OF PENNDOT PUBLICATION 408, CURRENT EDITION, AND AS MODIFIED HEREIN.
2. PROVIDE TRANSVERSE CONTROL JOINTS AT 5' INTERVALS 1/8" WIDE AND 1" DEEP.
3. PLACE 1/2" PREMOLDED, EXPANSION JOINT MATERIAL FOR THE FULL DEPTH OF LOW FLOW CHANNEL EVERY 30' AND AT STRUCTURES.
4. WEATHER PROTECTION SHALL BE USED IN ACCORDANCE WITH PENNDOT PUBLICATION 408, CURRENT EDITION.
5. PENETRATING SEALER TO BE APPLIED IMMEDIATELY FOLLOWING FINISHING OPERATIONS. PENETRATING SEALER TO BE AQURON CPT2000 OR APPROVED EQUAL.
6. ALL STRUCTURES NEED TO BE DOWEL PINNED PRIOR TO LOW-FLOW CHANNEL BEING POURED.
7. DOWEL PINS TO BE 5/8"Ø MIN., EPOXY COATED, AND SET 6" INTO STRUCTURE, GROUTED WITH A NON SHRINK GROUT AND EXTEND 6" FROM STRUCTURE.

UPPER DUBLIN TOWNSHIP STANDARD DETAIL
CONCRETE LOW FLOW CHANNEL

 Metz
Engineers

DATE 10-2013

NOT TO SCALE

CC205

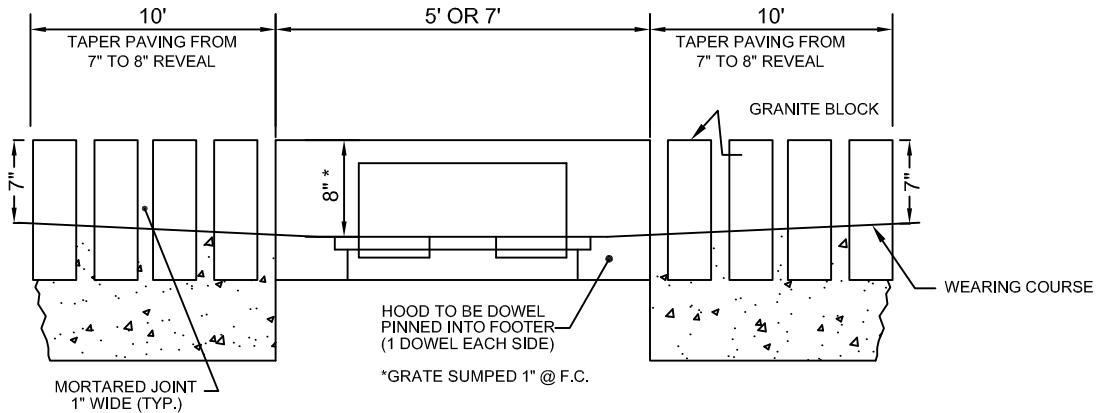

* SEAL CURBLINE AFTER WEARING COURSE PLACEMENT WITH RUBBERIZED JOINT SEALING MATERIAL TYPE 4(C) AS MANUFACTURED BY CRAFCO, INC. OR APPROVED EQUAL. 2" VERTICALLY UP FACE OF CURB, 12" HORIZONTALLY OUT FROM FACE OF CURB.

ELEVATION ADJACENT TO 4FT. OR 6FT. SPECIAL TOP FOR BELGIAN BLOCK CURB

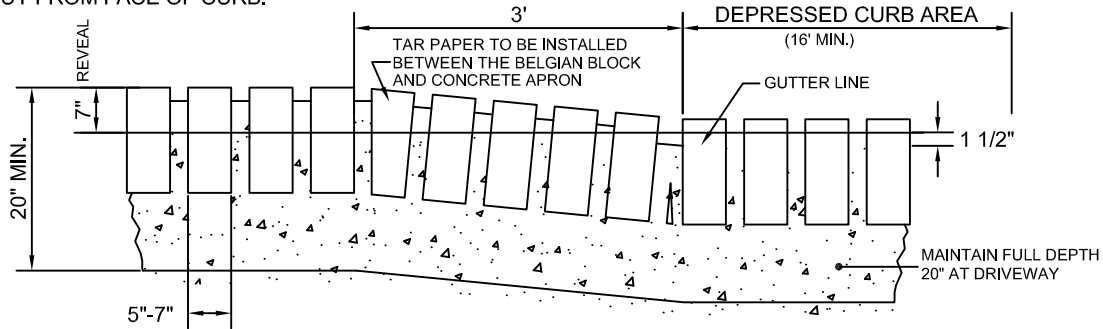

DEPRESSED BELGIAN BLOCK CURB AT DRIVEWAY

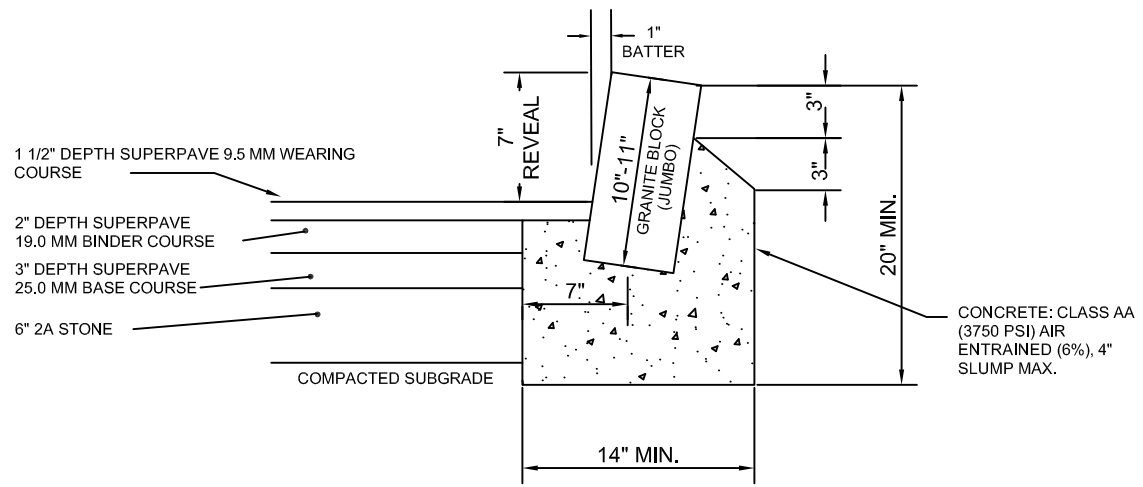

NOTE:
 1. WEATHER PROTECTION AND CURING COMPOUNDS SHALL BE USED IN ACCORDANCE WITH PENNDOT SPECIFICATIONS PUB. 408 CURRENT EDITION.
 2. CURING COMPOUND SHALL BE AASHTO M148 TYPE 1-D TO BE USED IN ACCORDANCE WITH PENNDOT PUB. 408, SEC. 711.2, CURRENT EDITION.

UPPER DUBLIN TOWNSHIP STANDARD DETAIL
BELGIAN BLOCK CURB AND PAVING DETAIL

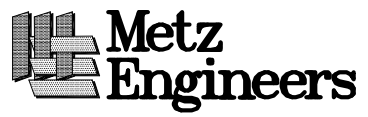

DATE	10-2013	NOT TO SCALE	CC206
------	---------	--------------	-------

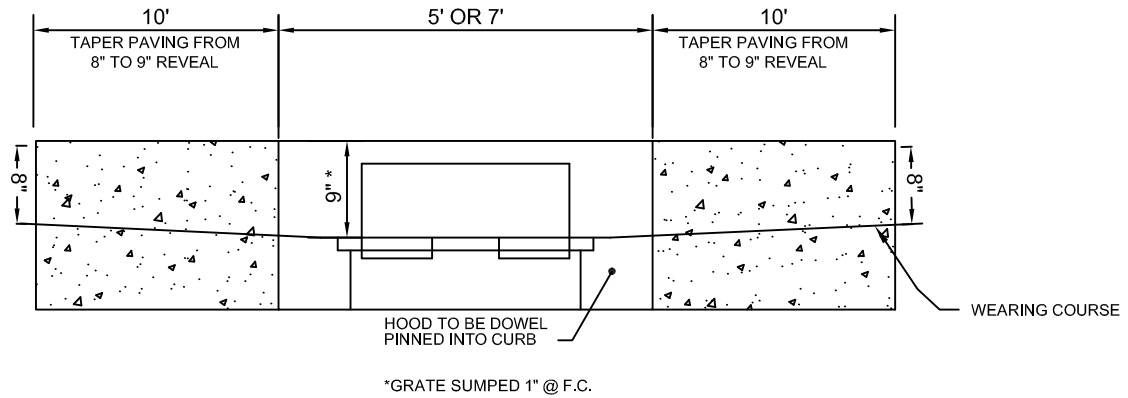

ELEVATION ADJACENT TO 4FT. OR 6FT. SPECIAL INLET

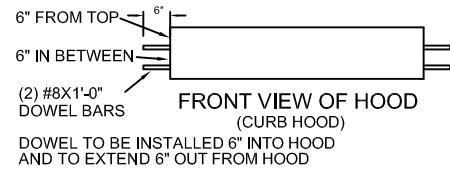
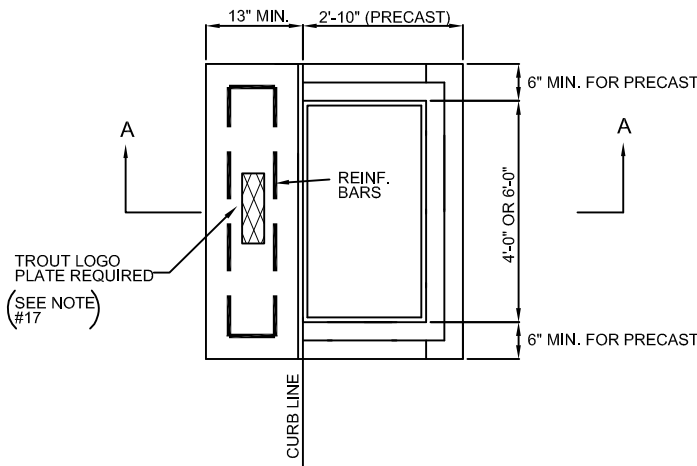

NOTES:

1. CONSTRUCT INLETS IN ACCORDANCE WITH PENNDOT 408 CURRENT EDITION, RC-STANDARDS CURRENT EDITION AND AS MODIFIED HEREIN.
2. CONSTRUCT INLETS THAT EXCEED 5 FEET IN HEIGHT WITH STEPS SIMILAR TO MANHOLES.
3. CONCRETE TO BE CLASS AA MODIFIED DESIGN COMPRESSIVE STRENGTH (4000 P.S.I.).
4. PROVIDE STEEL REINFORCEMENT IN ACCORDANCE WITH SEC.709 PROVIDE MINIMUM YIELD STRENGTH OF 60,000 P.S.I. REINFORCE PER PENNDOT RC STANDARDS RC 46M, CURRENT EDITION. PROVIDE REINFORCEMENT FOR TYPE 4 INLET BOX.
5. CLEAR COVER FOR STEEL:

WALLS:	CAST-IN-PLACE	2"
	PRECAST	1 1/2"
FOOTINGS:	CAST-IN-PLACE	2 1/2" (TOP BARS)
		3" (BOTTOM BARS)
		2" (SIDE COVER)
	PRECAST	2" (TOP BARS)
		1 1/2" (BOTTOM BARS)
		1 1/2" (SIDE COVER)
6. ONE PRECAST ADJUSTMENT RING AND NON SHRINK GROUT IS REQUIRED FOR UP TO 10" OF ADJUSTMENT. FOR ADJUSTMENT ABOVE 10" A PRECAST CONCRETE RISER OR RISERS ARE REQUIRED. BRICK OR BRICK AND MORTAR ARE NOT ALLOWED FOR GRADE ADJUSTMENTS.
7. ALL INLETS REQUIRE CONSTRUCTION JOINTS OR KEYS FOR RISER SECTIONS AND PRECAST COVER ADJUSTMENT SLABS.
8. MASTIC IS REQUIRED AT ALL CONSTRUCTION JOINTS OR KEYS UNDER STEEL FRAMES AND AS REQUIRED BY THE TOWNSHIP ENGINEER OR HIS/HER REPRESENTATIVE IN THE FIELD.
9. PROVIDE WEEP HOLES FOR DRAINAGE. AT THE DIRECTION OF TOWNSHIP ENGINEER OR HIS/HER REPRESENTATIVE IN THE FIELD.
10. DOWEL PIN ALL HOODS INTO CURB. (2) #8X1'-0" DOWELS BARS EACH SIDE OF HOOD.
11. FRAMES & GRATES SHALL BE PADOT TYPE C STRUCTURAL STEEL.
12. GRATES SHALL BE PADOT "BICYCLE SAFE".
13. PIPE OPENINGS ARE PERMITTED TO BE IN EACH WALL WHEN CORNER PENETRATIONS ARE NOT REQUIRED.
14. IF CORNER PENETRATION IS REQUIRED, PIPE OPENINGS ARE PERMITTED IN ONE (1) CORNER AND IN THE TWO (2) OTHER WALLS NOT AFFECTED BY THE CORNER PENETRATION.
15. ALL PENETRATIONS/OPENINGS AROUND THE PIPES(S) MUST BE FORMED AND FILLED WITH CLASS AA (3750 PSI MINIMUM COMPRESSIVE STRENGTH) CEMENT CONCRETE. REFER TO UPPER DUBLIN TOWNSHIP DETAIL DR348.
16. FORM BOTTOM OF INLET USING CLASS AA CEMENT CONCRETE. TO CHANNEL THE FLOW TOWARD THE OUTLET PIPE. REFER TO UD TWP DETAIL DR349.
17. PROVIDE TROUT LOGO PLATE, PRODUCT NO. 00700160, AS MANUFACTURED BY EAST JORDAN IRON WORKS OR APPROVED EQUAL. PLATE TO BE CAST INTO TOP OF HOOD. SEE UPPER DUBLIN TOWNSHIP DETAIL # DR345.

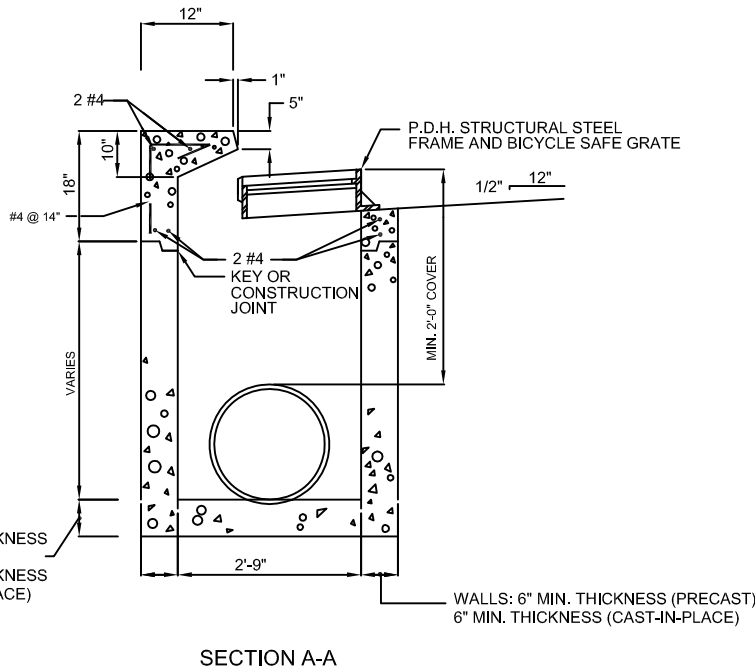

UPPER DUBLIN TOWNSHIP STANDARD DETAIL
4 FOOT AND 6 FOOT SPECIAL
INLETS



DATE 10-2013

NOT TO SCALE

DR300

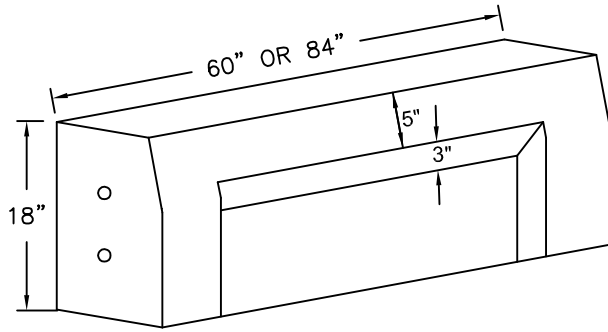

FRONT VIEW

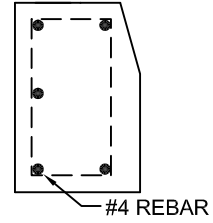

REINFORCEMENT

TROUT LOGO
PLATE REQUIRED
(SEE NOTE)
#6

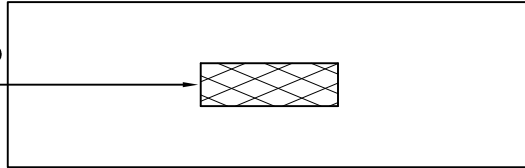

TOP VIEW

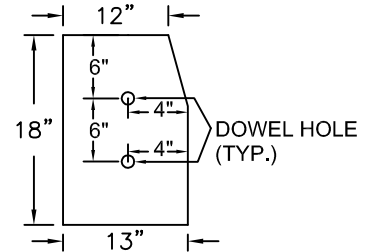

SIDE VIEW

NOTES

1. CONSTRUCT IN ACCORDANCE WITH PENNDOT PUB. 408, CURRENT EDITION, SECTION 714 AND MODIFIED HEREIN:
2. ALL CONCRETE SHALL BE CLASS AA MODIFIED DESIGN COMPRESSIVE STRENGTH (4000 PSI) AND SHALL COMPLY WITH THE REQUIREMENTS OF PENNDOT SPECIFICATIONS PUB. 408 CURRENT EDITION, SEC. 704. FOR CEMENT CONCRETE.
3. HOOD TO BE REINFORCED PER PENNDOT SPECIFICATIONS PUB. 408 CURRENT EDITION.
4. ALL REINFORCEMENT SHALL COMPLY WITH PENNDOT SPECIFICATION PUB. 408 CURRENT EDITION SEC. 709. AND GUIDELINES OF PENNDOT RC STANDARDS CURRENT EDITION.
5. APPLY PENETRATING SEALER BEFORE SHIPMENT. PENETRATING SEALER TO BE AQURON CPT 2000 OR APPROVED EQUAL.
6. PROVIDE TROUT LOGO PLATE, PRODUCT NO. 00700160, AS MANUFACTURED BY EAST JORDAN IRON WORKS OR APPROVED EQUAL. PLATE TO BE CAST INTO TOP OF HOOD. SEE UPPER DUBLIN TOWNSHIP DETAIL #DR345.

UPPER DUBLIN TOWNSHIP STANDARD DETAIL
HOOD DETAIL



DATE 10-2013

NOT TO SCALE

DR301

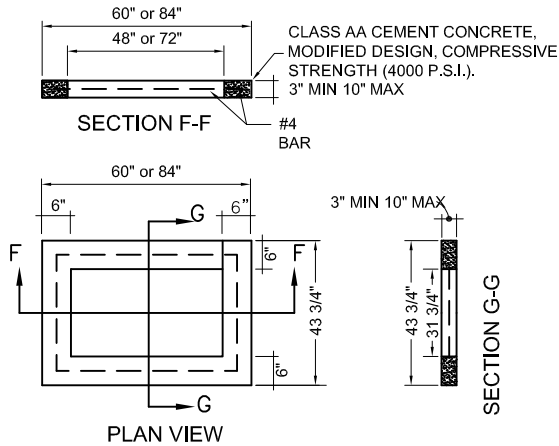

NOTES:

1. PROVIDE MATERIALS AND CONSTRUCTION IN ACCORDANCE WITH THE REQUIREMENTS OF PENNDOT PUBLICATION 408, CURRENT EDITION, SECTIONS 605, 606 AND 714 AND PENNDOT RC STANDARDS, CURRENT EDITION. ONLY GRATES AND GRADE ADJUSTMENT SYSTEMS SUPPLIED BY A MANUFACTURER LISTED IN BULLETIN 15 SHALL BE PERMITTED. FOR A BULLETIN 15 LISTING, SUBMIT A 24"X36" REPRODUCIBLE SHOP DRAWING TO THE MATERIALS AND TESTING DIVISION, BUREAU OF CONSTRUCTION AND MATERIALS FOR REVIEW AND APPROVAL.
2. PRECAST CONCRETE GRADE ADJUSTMENT RINGS TO BE SET ON NON SHRINK GROUT AND/OR MASTIC PAD TO PROVIDE FULL BEARING ON THE SUPPORTING SURFACE.
3. ONLY ONE GRADE ADJUSTMENT RING IS PERMITTED.

**UPPER DUBLIN TOWNSHIP STANDARD DETAIL
4 FOOT & 6 FOOT SPECIAL INLET
GRADE ADJUSTMENT RINGS**



DATE 10-2013

NOT TO SCALE

DR302

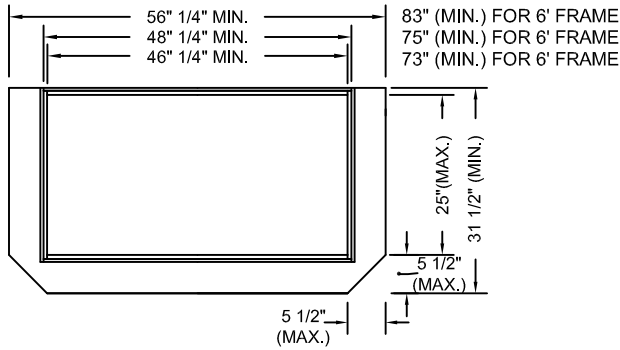

STRUCTURAL STEEL FABRICATION

TYPE C FRAME

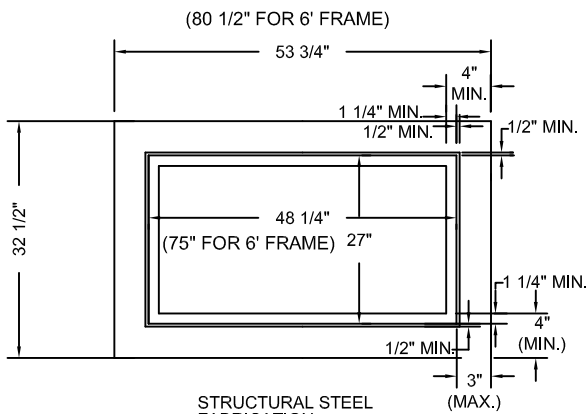

STRUCTURAL STEEL FABRICATION

TYPE M FRAME

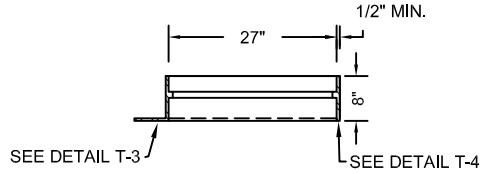

SECTION D-D

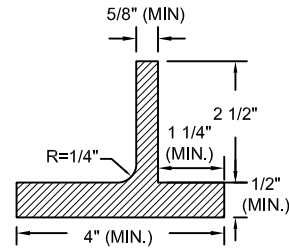

SECTION A-A

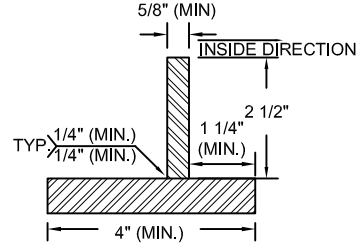

SECTION B-B

NOTES

1. THIS SHEET DEPICTS THE DIMENSIONS REQUIRED FOR UNIFORMITY AND INTERCHANGEABILITY. IT DOES NOT INCLUDE DETAILS REQUIRED FOR FABRICATION OR MANUFACTURING. ONLY FRAMES SUPPLIED BY A MANUFACTURER LISTED IN BULLETIN 15 SHALL BE PERMITTED.
2. PROVIDE STRUCTURAL STEEL FRAMES, SUPPLIED BY A MANUFACTURER LISTED IN BULLETIN 15.
3. PROVIDE MATERIALS AND WORKMANSHIP IN ACCORDANCE WITH PENNDOT PUB. 408 CURRENT EDITION AND PENNDOT RC STANDARD, RC 45M, CURRENT EDITION.
4. WELD STRUCTURAL STEEL GRATES IN ACCORDANCE WITH THE REQUIREMENTS OF PUBLICATION 408, SECTION 1105, CURRENT EDITION.
5. DESIGN FRAMES TO MEET HS 25 LIVE LOADING.
6. COAT STRUCTURAL STEEL FRAMES WITH AN APPROVED BITUMINOUS PAINT. AS AN ALTERNATE TO BITUMINOUS PAINT, GALVANIZE STRUCTURAL STEEL GRATES AND FRAMES IN ACCORDANCE WITH SECTION 1105.02(S).

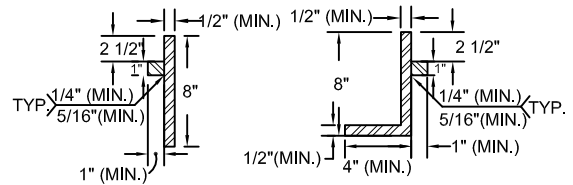

DETAIL T-1

DETAIL T-2

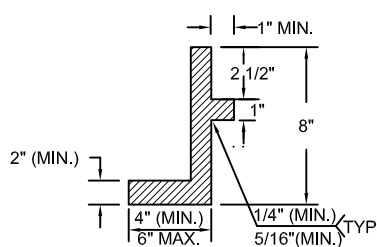

DETAIL T-3

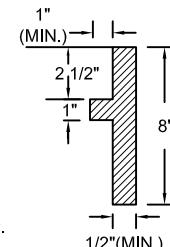

DETAIL T-4

**UPPER DUBLIN TOWNSHIP STANDARD DETAIL
STRUCTURAL STEEL INLET FRAMES**



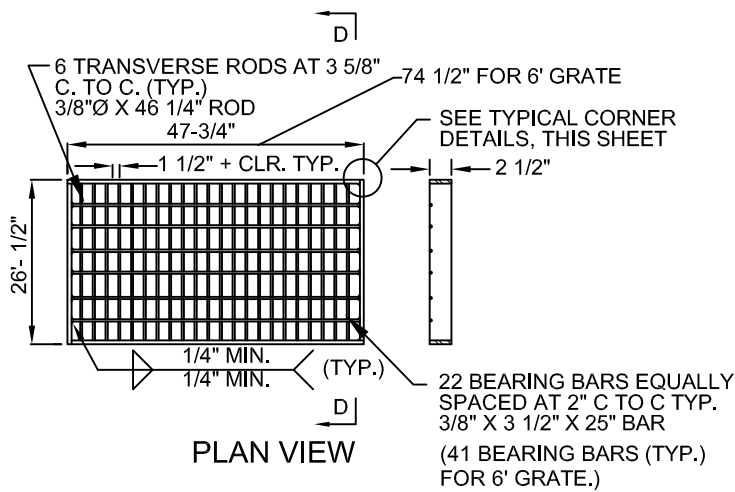

PLAN VIEW

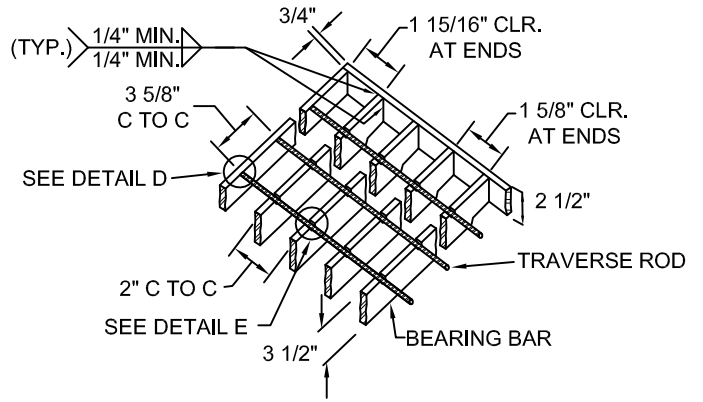

BAR AND ROD SPACING DETAIL

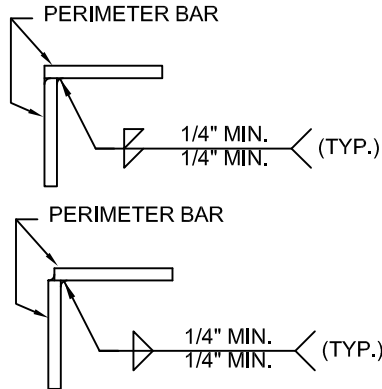

TYPICAL CORNER DETAILS

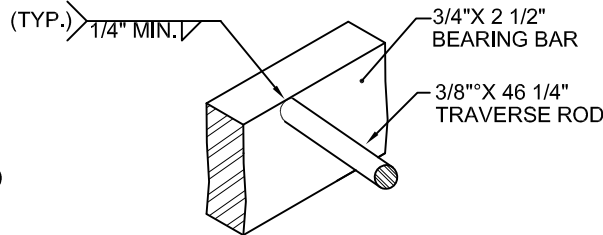

DETAIL D

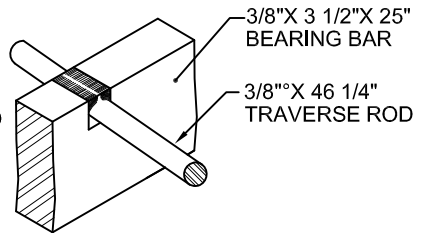

DETAIL E

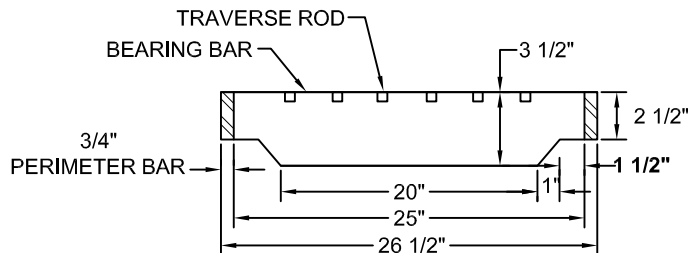

SECTION D-D

NOTES:

1. THIS SHEET DEPICTS THE DIMENSIONS REQUIRED FOR UNIFORMITY AND INTERCHANGEABILITY. IT DOES NOT INCLUDE DETAILS REQUIRED FOR FABRICATION OR MANUFACTURING. ONLY GRATES SUPPLIED BY A MANUFACTURER LISTED IN BULLETIN 15 SHALL BE PERMITTED.
2. PROVIDE MATERIALS AND WORKMANSHIP IN ACCORDANCE WITH PENNDOT PUB. 408 CURRENT EDITION AND PENNDOT RC STANDARDS, RC45M, CURRENT EDITION.
3. WELD STRUCTURAL STEEL GRATES IN ACCORDANCE WITH THE REQUIREMENTS OF PUBLICATION 408, SECTION 1105.
4. PROVIDE TRANSVERSE BARS, MEETING THE REQUIREMENTS OF PUB. 408. PROVIDE GRADE 50 STRUCTURAL STEEL FOR ALL PERIMETER AND BEARING BARS.
5. DESIGN GRATES TO MEET HS 25 LIVE LOADING.
6. FABRICATE SLOTS BY BURNING, DRILLING, SHEARING OR PUNCHING. HAVE THE BOTTOM OF ALL BURNED OR DRILLED SLOTS CONFORM TO THE SHAPE OF THE ROD.
7. PROVIDE STRUCTURAL STEEL GRATES WITH THE GRATE SPACERS LOCATED FLUSH ALONG THE TOP SURFACE OF THE GRATE.
8. PROVIDE A 1" WIDE YELLOW PAINT STRIP LENGTHWISE ALONG THE TOP OF THE INLET GRATE AS A FIELD IDENTIFIER OF CONFORMANCE TO THESE DETAILS. FOR PERMANENT IDENTIFICATION PLACE TWO RAISED WELD BEADS, EACH TWO INCHES LONG, ON THE CENTER TOP OF ONE LONGITUDINAL PERIMETER BAR.
9. DO NOT USE CAST IRON GRATES.
10. COAT STRUCTURAL STEEL GRATES WITH AN APPROVED BITUMINOUS PAINT. AS AN ALTERNATE TO BITUMINOUS PAINT, GALVANIZE STRUCTURAL STEEL GRATES IN ACCORDANCE WITH SECTION 1105.02(S).

UPPER DUBLIN TOWNSHIP STANDARD DETAIL
 STRUCTURAL STEEL GRATE
 BICYCLE SAFE



DATE 10-2013

NOT TO SCALE

DR304

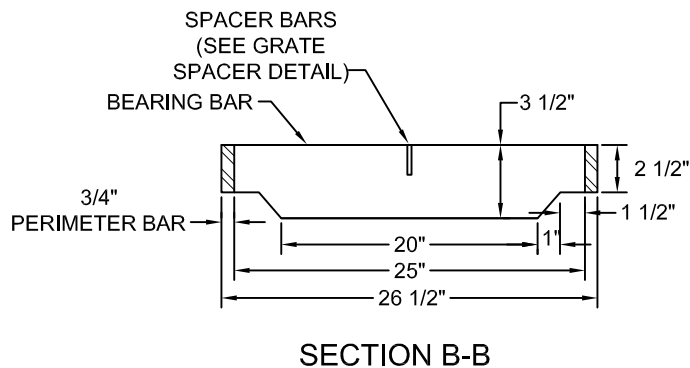
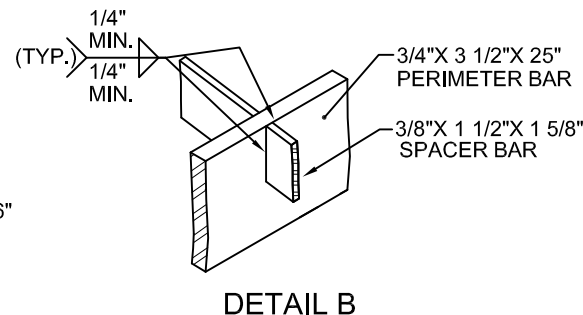
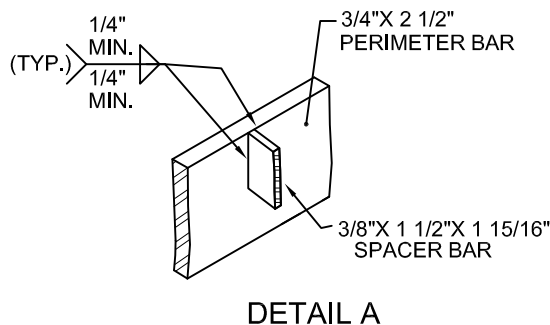
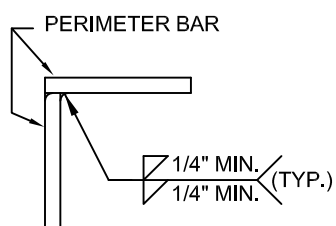
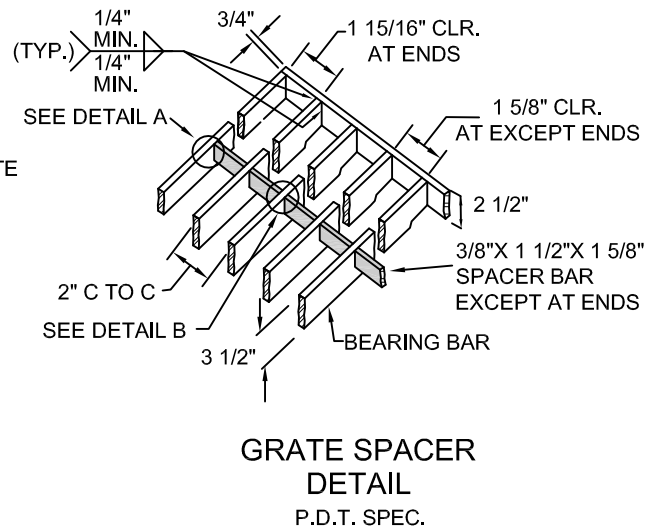
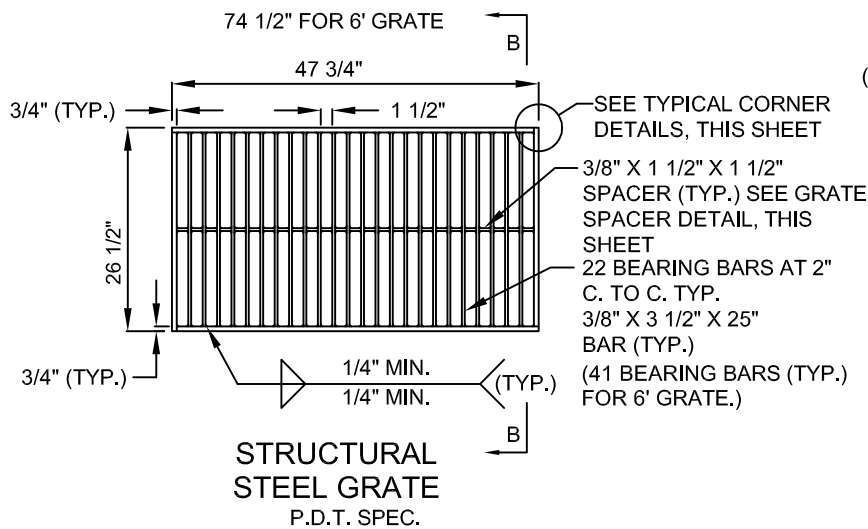

NOTES:

1. THIS SHEET DEPICTS THE DIMENSIONS REQUIRED FOR UNIFORMITY AND INTERCHANGEABILITY. IT DOES NOT INCLUDE DETAILS REQUIRED FOR FABRICATION OR MANUFACTURING. ONLY GRATES SUPPLIED BY A MANUFACTURER LISTED IN BULLETIN 15 SHALL BE PERMITTED.
2. PROVIDE MATERIALS AND WORKMANSHIP IN ACCORDANCE WITH PENNDOT PUB. 408 CURRENT EDITION AND PENNDOT RC STANDARDS, RC45M, CURRENT EDITION.
3. WELD STRUCTURAL STEEL GRATES IN ACCORDANCE WITH THE REQUIREMENTS OF PENNDOT PUBLICATION 408, SECTION 1105.03(R).
4. PROVIDE TRANSVERSE BARS, MEETING THE REQUIREMENTS OF PENNDOT PUBLICATION 408.
5. FABRICATE SLOTS BY BURNING, DRILLING, SHEARING OR PUNCHING. HAVE THE BOTTOM OF ALL BURNED OR DRILLED SLOTS CONFORM TO THE SHAPE OF THE ROD.
6. PROVIDE STRUCTURAL STEEL GRATES WITH THE GRATE SPACERS LOCATED FLUSH ALONG THE TOP SURFACE OF THE GRATE.
7. DO NOT USE CAST IRON GRATES.
8. COAT STRUCTURAL STEEL GRATES WITH BITUMINOUS PAINT. AS AN ALTERNATE TO BITUMINOUS PAINT, GALVANIZE STRUCTURAL STEEL GRATES IN ACCORDANCE WITH SECTION 1105.02(S).

UPPER DUBLIN TOWNSHIP STANDARD DETAIL
STRUCTURAL STEEL GRATE



DATE 10-2013

NOT TO SCALE

DR305

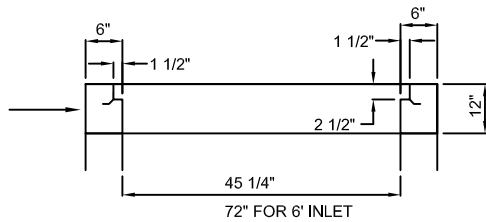
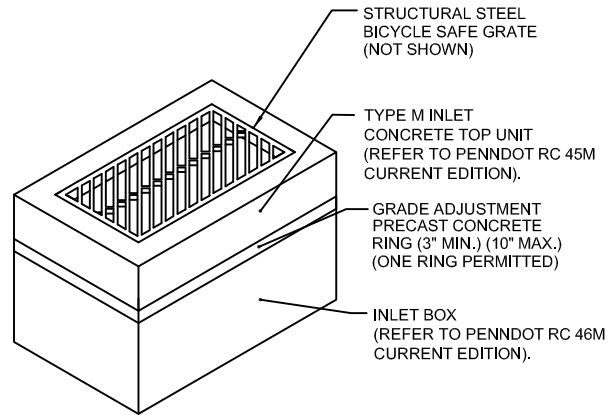
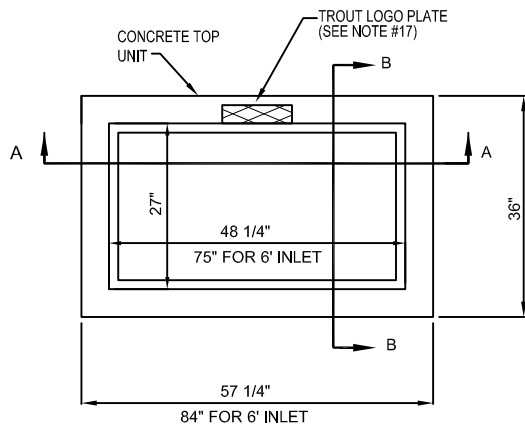

SECTION A-A

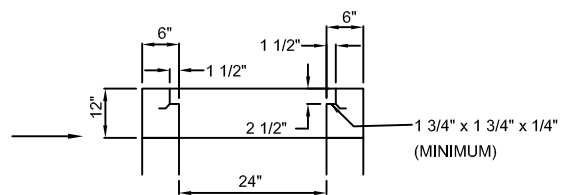

SECTION B-B

NOTES

1. CONSTRUCTION REQUIREMENTS

- A. CONSTRUCT IN ACCORDANCE WITH: PENNDOT 408, CURRENT EDITION, SECTIONS 605, 606, 714; PENNDOT RC STANDARDS, INCLUDING BUT NOT LIMITED TO RC 45M, RC 46M, CURRENT EDITION AND AS MODIFIED HEREIN.
 - B. MINIMUM CONCRETE COMPRESSIVE STRENGTH:
 CAST-IN-PLACE CLASS AA MODIFIED DESIGN COMPRESSIVE STRENGTH (4000 PSI)
 PRECAST CLASS AA MODIFIED DESIGN COMPRESSIVE STRENGTH (4000 PSI)
 - C. PROVIDE STEEL REINFORCEMENT IN ACCORDANCE WITH SEC. 709. PROVIDE MINIMUM YIELD STRENGTH OF 60,000 P.S.I.
 - D. CLEAR COVER FOR STEEL:
 WALLS: CAST-IN-PLACE 2"
 PRECAST 1 1/2"
 FOOTINGS: CAST-IN-PLACE 2 1/2" (TOP BARS)
 3" (BOTTOM BARS)
 2" (SIDE COVER)
 PRECAST 2" (TOP BARS)
 1 1/2" (BOTTOM BARS)
 1 1/2" (SIDE COVER)
 SLABS CAST-IN-PLACE 2" (TOP AND BOTTOM BARS)
2. THIS SHEET DEPICTS THE VARIOUS COMPONENTS REQUIRED FOR COMPLETE INLET ASSEMBLIES FOR INDIVIDUAL COMPONENTS AND OTHER SPECIAL DETAILS. FOR ADDITIONAL INFORMATION REFER TO PENNDOT RC STANDARDS, CURRENT EDITION.
3. THIS TYPE OF INLET SHOWN IS SUITED FOR A PARTICULAR SITUATION AS FOLLOWS:
 * TYPE M INLET IS DESIGNATED FOR INSTALLATION IN MEDIAN AREAS AND MOUNTABLE CURBS.

- 4. THE SELECTION OF COMPONENTS TO ACHIEVE A SPECIFIED INLET ASSEMBLY IS THE CONTRACTORS RESPONSIBILITY
- 5. FOR BASE SECTION REINFORCEMENT: PROVIDE REINFORCEMENT PER PENNDOT RC STANDARDS, RC 46M, CURRENT EDITION.
- 6. FOR RISER SECTION REINFORCEMENT: PROVIDE REINFORCEMENT PER PENNDOT RC STANDARDS, RC 46M, CURRENT EDITION.
- 7. FRAMES AND GRATES SHALL BE PADOT TYPE C STRUCTURAL STEEL.
- 8. PROVIDE WEEP HOLES FOR DRAINAGE AT THE DIRECTION OF THE TOWNSHIP ENGINEER OR HIS/HER REPRESENTATIVE IN THE FIELD.
- 9. GRATES SHALL BE PADOT "BICYCLE SAFE".
- 10. CONSTRUCT INLETS THAT EXCEED 5 FEET IN HEIGHT WITH STEPS SIMILAR TO MANHOLES.
- 11. ONE PRECAST CONCRETE ADJUSTMENT RING AND NON SHRINK GROUT REQUIRED FOR UP TO 10" OF ADJUSTMENT. A PRECAST CONCRETE RISER OR RISERS IS REQUIRED FOR ADJUSTMENT ABOVE 10". BRICK OR BRICK AND MORTAR ARE NOT ALLOWED FOR GRADE ADJUSTMENTS.
- 12. ALL INLETS REQUIRE CONSTRUCTION JOINTS OR KEYS FOR RISER SECTIONS AND PRECAST COVER ADJUSTMENT SLABS.
- 13. MASTIC REQUIRED AT ALL CONSTRUCTION JOINTS OR KEYS. UNDER STEEL FRAMES AND AS REQUIRED BY THE TOWNSHIP ENGINEER OR HIS/HER REPRESENTATIVE IN THE FIELD.
- 14. FORM BOTTOM OF INLET USING CLASS AA CEMENT CONCRETE. TO CHANNEL THE FLOW TOWARD THE OUTLET PIPE. REFER TO UD TWP DETAIL DR349.
- 15. PIPE OPENINGS ARE PERMITTED TO BE IN EACH WALL WHEN CORNER PENETRATIONS ARE NOT REQUIRED.
- 16. IF CORNER PENETRATION IS REQUIRED, PIPE OPENINGS ARE PERMITTED IN ONE (1) CORNER AND IN THE TWO (2) OTHER WALLS NOT AFFECTED BY THE CORNER PENETRATION.
- 17. PROVIDE TROUT LOGO PLATE, PRODUCT NO. 00700360, AS MANUFACTURED BY EAST JORDAN IRON WORKS OR APPROVED EQUAL. PLATE TO BE CAST INTO TOP OF HOOD. SEE UPPER DUBLIN TOWNSHIP DETAIL #346.
- 18. ALL PENETRATIONS/OPENINGS AROUND THE PIPES(S) MUST BE FORMED AND FILLED WITH CLASS AA (3750 PSI MINIMUM COMPRESSIVE STRENGTH) CEMENT CONCRETE. REFER TO UPPER DUBLIN TOWNSHIP DETAIL DR348.
- 19. APPLY PENETRATING SEALER TO ALL INLET TOPS BEFORE SHIPMENT. PENETRATING SEALER TO BE AQURON CPT 2000 OR APPROVED EQUAL.

UPPER DUBLIN TOWNSHIP STANDARD DETAIL
TYPE "M" INLET- (4' & 6')



DATE 10-2013

NOT TO SCALE

DR306

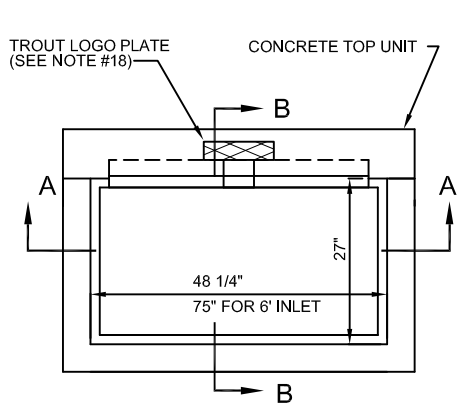

TOP VIEW

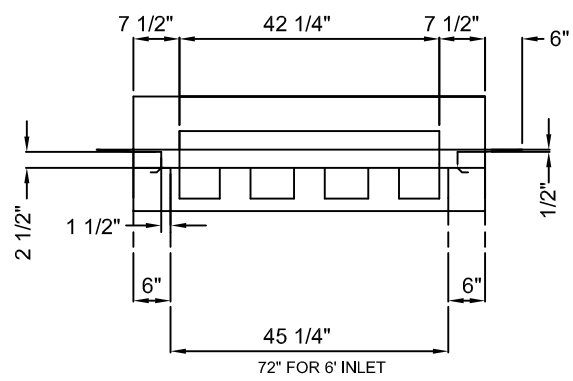
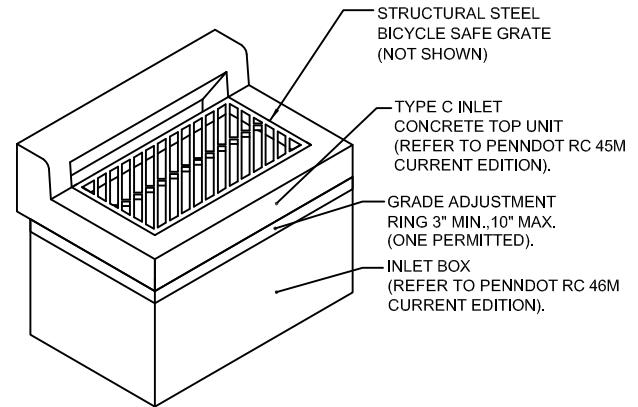

SECTION A-A

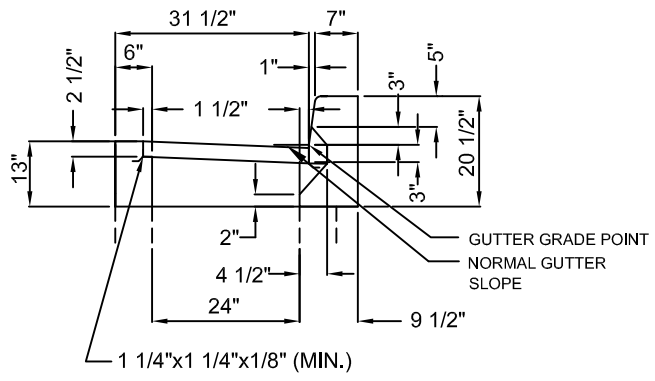

SECTION B-B

NOTES

1. CONSTRUCTION REQUIREMENTS
 - A. CONSTRUCT IN ACCORDANCE WITH: PENNDOT 408, CURRENT EDITION, SECTIONS 605, 606, 714, PENNDOT RC STANDARDS, INCLUDING BUT NOT LIMITED TO RC 45M, RC 46M, CURRENT EDITION AND AS MODIFIED HEREIN.
 - B. MINIMUM CONCRETE COMPRESSIVE STRENGTH:

CAST-IN-PLACE	CLASS AA MODIFIED DESIGN COMPRESSIVE STRENGTH (4000 PSI)
PRECAST	CLASS AA MODIFIED DESIGN COMPRESSIVE STRENGTH (4000 PSI)
 - C. PROVIDE STEEL REINFORCEMENT IN ACCORDANCE WITH SEC. 709. PROVIDE MINIMUM YIELD STRENGTH OF 60,000 P.S.I.
 - D. CLEAR COVER FOR STEEL:

WALLS:	CAST-IN-PLACE 2"
	PRECAST 1 1/2"
FOOTINGS:	CAST-IN-PLACE 2 1/2" (TOP BARS)
	3" (BOTTOM BARS)
	2" (SIDE COVER)
	PRECAST 2" (TOP BARS)
	1 1/2" (BOTTOM BARS)
	1 1/2" (SIDE COVER)
SLABS	CAST-IN-PLACE 2" (TOP AND BOTTOM BARS)
2. THIS SHEET DEPICTS THE VARIOUS COMPONENTS REQUIRED FOR COMPLETE INLET ASSEMBLIES FOR INDIVIDUAL COMPONENTS AND OTHER SPECIAL DETAILS. FOR ADDITIONAL INFORMATION REFER TO PENNDOT RC STANDARDS, CURRENT EDITION.
3. THIS INLET SHOWN IS SUITED FOR A PARTICULAR SITUATION AS FOLLOWS:
 - * TYPE C INLET IS DESIGNATED FOR INSTALLATION WITH NON-MOUNTABLE CURBS.
4. THE SELECTION OF COMPONENTS TO ACHIEVE A SPECIFIED INLET ASSEMBLY IS THE CONTRACTORS RESPONSIBILITY
5. FOR BASE SECTION REINFORCEMENT, PROVIDE REINFORCEMENT PER PENNDOT RC STANDARDS, RC 46M, CURRENT EDITION.
6. FOR RISER SECTION REINFORCEMENT: PROVIDE REINFORCEMENT PER PENNDOT RC STANDARDS, RC 46M, CURRENT EDITION.
7. FRAMES AND GRATES SHALL BE PADOT TYPE C STRUCTURAL STEEL.
8. PROVIDE WEEP HOLES FOR DRAINAGE AT THE DIRECTION OF THE TOWNSHIP ENGINEER OR HIS/HER REPRESENTATIVE IN THE FIELD.
9. GRATES SHALL BE PADOT "BICYCLE SAFE".
10. DOWEL PIN ALL HOODS INTO CURB W/(2) #8X1'-0" DOWEL BARS.
11. CONSTRUCT INLETS THAT EXCEED 5 FEET IN HEIGHT WITH STEPS SIMILAR TO MANHOLES.
12. ONE PRECAST CONCRETE ADJUSTMENT RING AND NON SHRINK GROUT REQUIRED FOR UP TO 10" OF ADJUSTMENT. A PRECAST CONCRETE RISER OR RISERS IS REQUIRED FOR ADJUSTMENT ABOVE 10". BRICK OR BRICK AND MORTAR ARE NOT ALLOWED FOR GRADE ADJUSTMENTS.
13. ALL INLETS REQUIRE CONSTRUCTION JOINTS OR KEYS FOR RISER SECTIONS AND PRECAST COVER ADJUSTMENT SLABS.
14. FORM BOTTOM OF INLET USING CLASS AA CEMENT CONCRETE. TO CHANNEL THE FLOW TOWARD THE OUTLET PIPE. REFER TO UD TWP DETAIL DR349.
15. MASTIC REQUIRED AT ALL CONSTRUCTION JOINTS OR KEYS. UNDER STEEL FRAMES AND AS REQUIRED BY THE TOWNSHIP ENGINEER OR HIS/HER REPRESENTATIVE IN THE FIELD.
16. PIPE OPENINGS ARE PERMITTED TO BE IN EACH WALL WHEN CORNER PENETRATIONS ARE NOT REQUIRED.
17. IF CORNER PENETRATION IS REQUIRED, PIPE OPENINGS ARE PERMITTED IN ONE (1) CORNER AND IN THE TWO (2) OTHER WALLS NOT AFFECTED BY THE CORNER PENETRATION.
18. PROVIDE TROUT LOGO PLATE, PRODUCT NO. 00700160, AS MANUFACTURED BY EAST JORDAN IRON WORKS OR APPROVED EQUAL. PLATE TO BE CAST INTO TOP OF HOOD. SEE UPPER DUBLIN TOWNSHIP DETAIL #345.
19. ALL PENETRATIONS/OPENINGS AROUND THE PIPES(S) MUST BE FORMED AND FILLED WITH CLASS AA (3750 PSI MINIMUM COMPRESSIVE STRENGTH) CEMENT CONCRETE. REFER TO UPPER DUBLIN TOWNSHIP DETAIL DR348.
20. APPLY PENETRATING SEALER TO ALL INLET TOPS BEFORE SHIPMENT. PENETRATING SEALER TO BE AQUORON CPT 2000 OR APPROVED EQUAL.

UPPER DUBLIN TOWNSHIP STANDARD DETAIL
TYPE "C" INLET- (4' & 6')



DATE	10-2013	NOT TO SCALE	DR307
------	---------	--------------	-------

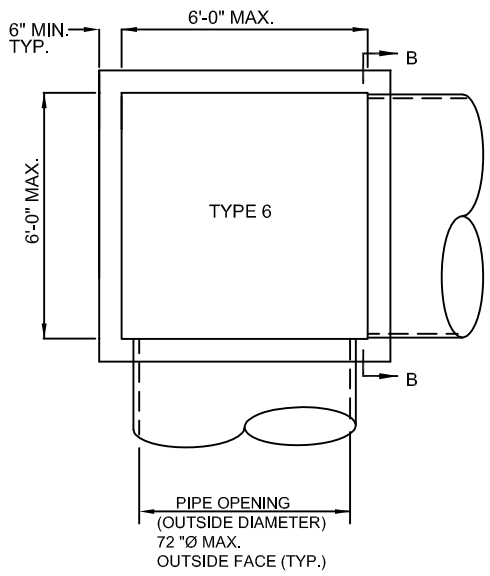
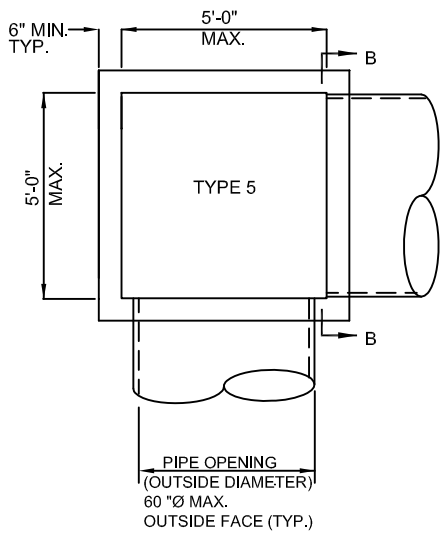
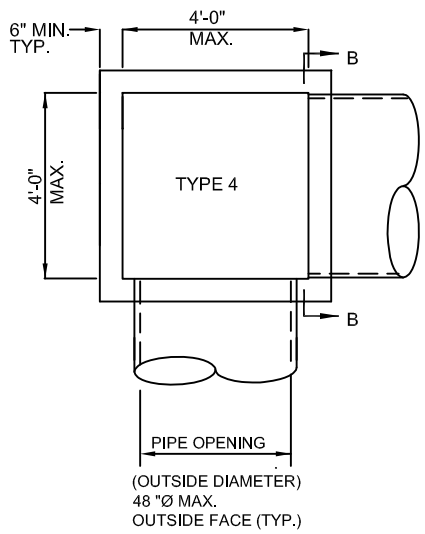
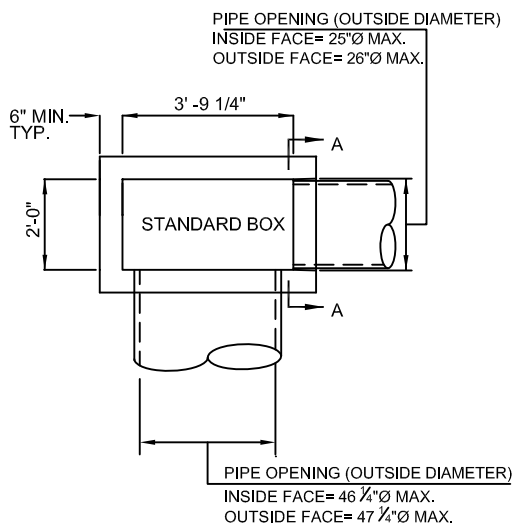

UPPER DUBLIN TOWNSHIP STANDARD DETAIL
INLET BOXES / INLET BOX TYPES
(PRECAST)



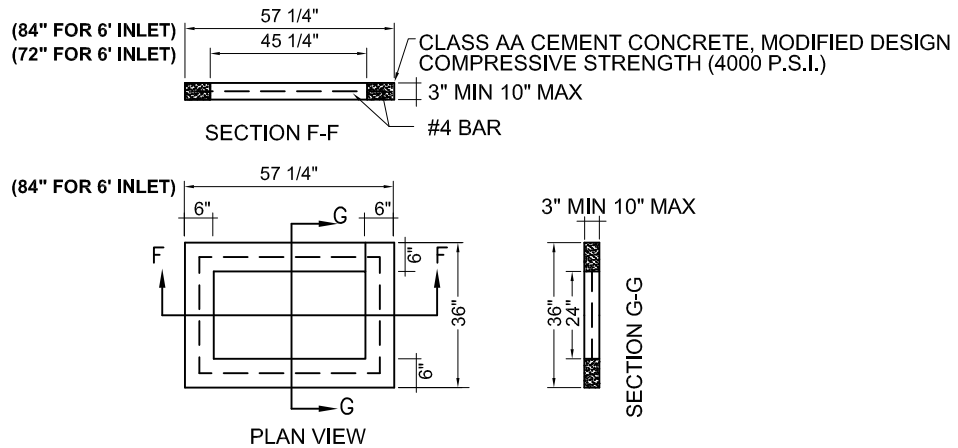

NOTES:

1. PROVIDE MATERIALS AND CONSTRUCTION IN ACCORDANCE WITH THE REQUIREMENTS OF PENNDOT PUBLICATION 408, CURRENT EDITION, SECTIONS 605, 606 AND 714. ONLY GRATES AND GRADE ADJUSTMENT SYSTEMS SUPPLIED BY A MANUFACTURER LISTED IN BULLETIN 15 SHALL BE PERMITTED. FOR A BULLETIN 15 LISTING, SUBMIT A 24"X36" REPRODUCIBLE SHOP DRAWING TO THE MATERIALS AND TESTING DIVISION, BUREAU OF CONSTRUCTION AND MATERIALS FOR REVIEW AND APPROVAL.
2. PRECAST CONCRETE GRADE ADJUSTMENT RINGS TO BE SET ON NON SHRINK GROUT AND/OR MASTIC PAD TO PROVIDE FULL BEARING ON THE SUPPORTING SURFACE.
3. ONLY ONE GRADE RING PERMITTED.

UPPER DUBLIN TOWNSHIP STANDARD DETAIL
TYPE "M" & TYPE "C"- 4' & 6'
GRADE ADJUSTMENT RINGS



DATE 10-2013

NOT TO SCALE

DR309

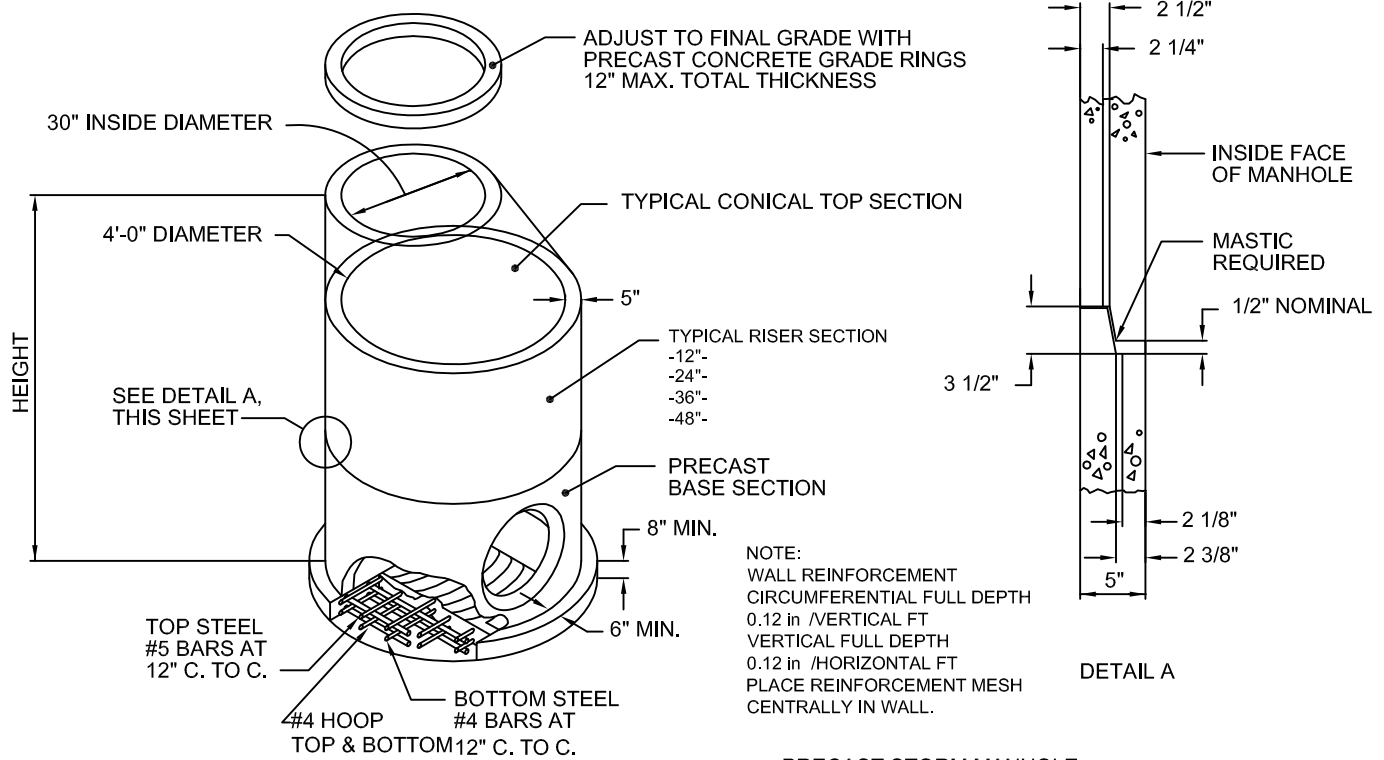

NOTE:
 WALL REINFORCEMENT
 CIRCUMFERENTIAL FULL DEPTH
 0.12 in /VERTICAL FT
 VERTICAL FULL DEPTH
 0.12 in /HORIZONTAL FT
 PLACE REINFORCEMENT MESH
 CENTRALLY IN WALL.

**PRECAST STORM MANHOLE
 FOR PIPES 30" INSIDE DIAMETER AND LESS**

NOTES

1. CONSTRUCTION REQUIREMENTS:
 - A. CONSTRUCT IN ACCORDANCE WITH PENNDOT PUBLICATION 408, CURRENT EDITION SECTIONS 605, 606 AND 714; AND ASTM C-478M-90, STANDARD SPECIFICATION FOR PRECAST REINFORCED CONCRETE MANHOLE SECTIONS, AS MODIFIED HEREIN.
 - B. MINIMUM CONCRETE CLASS:

CAST-IN-PLACE	CLASS AA MODIFIED DESIGN COMPRESSIVE STRENGTH (4000 PSI)
PRECAST	CLASS AA MODIFIED DESIGN COMPRESSIVE STRENGTH (4000 PSI)
 - C. PROVIDE STEEL REINFORCEMENT IN ACCORDANCE WITH ASTM A185, STEEL WELDED WIRE FABRIC ASTM A663/A663M & A675/A675M, PLAIN BILLET STEEL BARS OR ASTM A615/A615M, DEFORMED BILLET STEEL BARS. PROVIDE MINIMUM YIELD STRENGTH OF 400 MPa (60,000 PSI).
 - D. CLEAR COVER FOR STEEL:

WALLS:	CAST-IN-PLACE	50 (2")
	PRECAST	40 (1 1/2")
FOOTINGS:	CAST-IN-PLACE	60 (2 1/2") TOP BARS
		80 (3") BOTTOM BARS
		50 (2") SIDE COVER
	PRECAST	50 (2") TOP BARS
		40 (1 1/2") BOTTOM BARS
		40 (1 1/2") SIDE COVER
SLABS:	CAST-IN-PLACE	50 (2") TOP & BOTTOM BARS
2. FORM A CONCRETE CHANNEL AT THE BOTTOM OF THE MANHOLE CONFORMING TO THE SHAPE OF THE LOWER HALF OF THE INCOMING AND/OR OUTGOING PIPES. PROVIDE A FULL DEPTH U-SHAPED CHANNEL WHEN NECESSARY TO REDUCE ENERGY LOSSES.

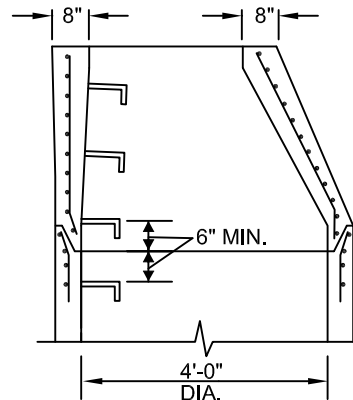

CONE SECTION

3. USE 127 (5") THICK WALLS WITH ONE (1) ROW OF REINFORCING, OR USE 254 (10") THICK OR GREATER WALLS WITH TWO (2) ROWS OF REINFORCING.
4. CONSTRUCTION JOINTS AND KEYS MAY BE CONSTRUCTED UPWARDS OR DOWNWARDS. CLEAN JOINTS AND KEYS THOROUGHLY BEFORE PLACING NEXT CONCRETE SEGMENT.
5. MASTIC REQUIRED AT ALL CONSTRUCTION JOINTS AND KEYS AND UNDER MANHOLE FRAME.
6. MANHOLES THAT EXCEED 5 FEET IN DEPTH SHALL BE CONSTRUCTED WITH STEPS. REFER TO UPPER DUBLIN TOWNSHIP DETAIL DR312 & DR313 FOR SPEC OF STEPS.
7. REFER TO UPPER DUBLIN TOWNSHIP DETAIL DR311 FOR FRAME AND COVER.

**UPPER DUBLIN TOWNSHIP STANDARD DETAIL
 PRECAST CONCRETE STORM
 MANHOLE**



DATE 10-2013

NOT TO SCALE

DR310

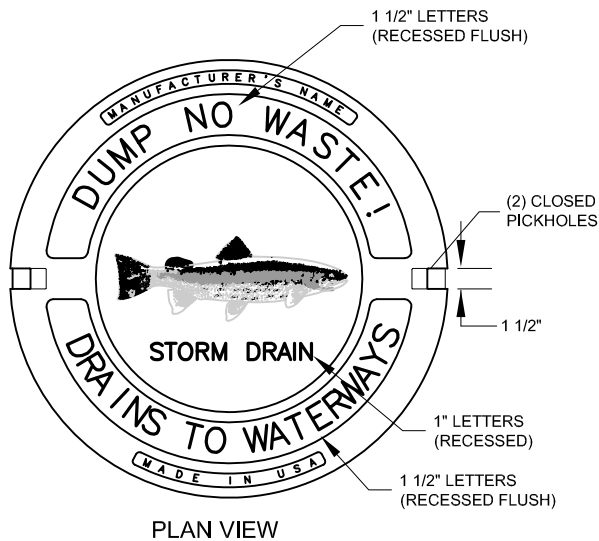

PLAN VIEW

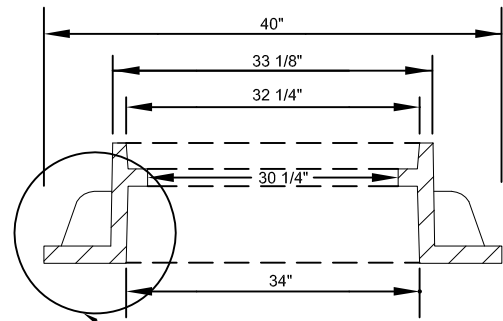

ELEVATION VIEW

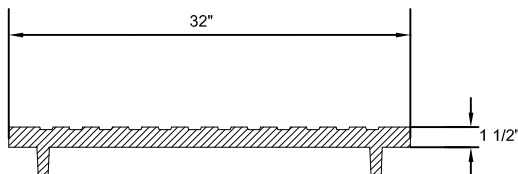

ELEVATION VIEW

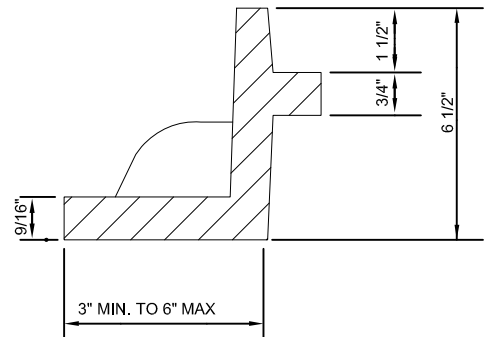

DETAIL C

CAST IRON MANHOLE FRAMES

NOTES:

1. PROVIDE MANHOLE FRAMES AND COVERS MEETING THE REQUIREMENTS OF PENNDOT PUBLICATION 408 SPECIFICATIONS SECTION 605.2(B) CURRENT EDITION AND AASHTO M306 CURRENT EDITION AND AS MODIFIED HEREIN.
2. DESIGN MANHOLE FRAME, COVER AND GRADE ADJUSTMENT RINGS FOR (HS25) LIVE LOAD.
3. PROVIDE MANHOLE FRAMES AND COVERS SUPPLIED BY MANUFACTURER AS LISTED IN BULLETIN 15.
4. PROVIDE MANHOLE FRAMES AND COVERS AS MANUFACTURED BY EAST JORDAN IRON WORKS (FRAME 1322Z, PRODUCT NO. 00132212 DIPPED. COVER 1480 AGS, PRODUCT NO. 00148159) OR APPROVED EQUAL.
5. PROVIDE A GASKET SEALING SYSTEM (DOVETAIL GROOVE AND CONTINUOUS GASKET), AS INDICATED IN DETAIL A. TO PREVENT INFLOW THROUGH THE BEARING SURFACES OF SURFACE RUNOFF WATER INTO THE MANHOLE SYSTEM, WHEN SPECIFIED. PROVIDE 1/4" DIA. ONE PIECE SELF-SEAL POLYISOPRENE ROUND GASKET. 40 DUROMETER GLUED IN PLACE. PROVIDE TWO LIFT HOLES AT 180 °AS INDICATED IN DETAIL B. TO FACILITATE COVER REMOVAL FOR SELF-SEALING MANHOLE COVER.
6. FRAME AND GRADE ADJUSTMENT RISER TO HAVE A MINIMUM 1" BEARING SEAT COVER.
7. LOCATE TOP OF FRAME OF ADJUSTMENT RISER 1/8" BELOW THE TOP OF ROADWAY SURFACE.
8. FRAME AND/OR PRECAST CONCRETE GRADE RINGS TO BE ATTACHED RIGIDLY TO TOP OF MANHOLE. USE 4 - 7/8" DIA. THREADED STUDS WITH HEX HEAD NUTS AND WASHERS, INSERTED THROUGH 1" DIA. HOLES THROUGH FRAME AND/OR RINGS. HOLES TO BE SPACED AT 90 DEGREES(36" DIA. BOLT CIRCLE) AND 2" FROM OUTSIDE EDGE OF FRAME. EMBED STUDS 4" (MINIMUM) INTO MANHOLE. GROUT STUDS INTO MANHOLE.
9. THE PRECAST CONCRETE GRADE RINGS TO BE SET ON NON SHRINK GROUT. MASTIC TO BE REQUIRED UNDER MANHOLE FRAME.
10. COAT CAST IRON FRAMES AND COVERS WITH AN APPROVED BITUMINOUS PAINT.

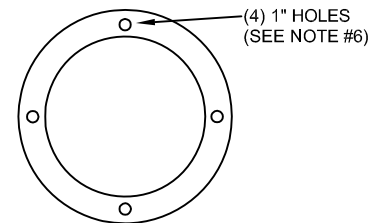

MANHOLE FRAME

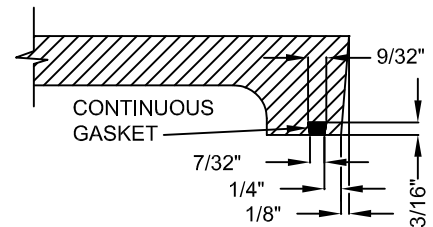

DETAIL A
GASKET SEALING SYSTEM
(REQUIRED)

UPPER DUBLIN TOWNSHIP STANDARD DETAIL
CAST IRON STORM SEWER
MANHOLE FRAME AND COVER



DATE 10-2013

NOT TO SCALE

DR311

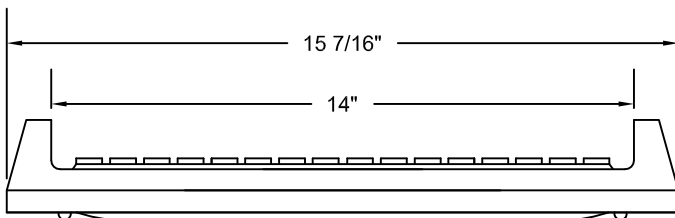
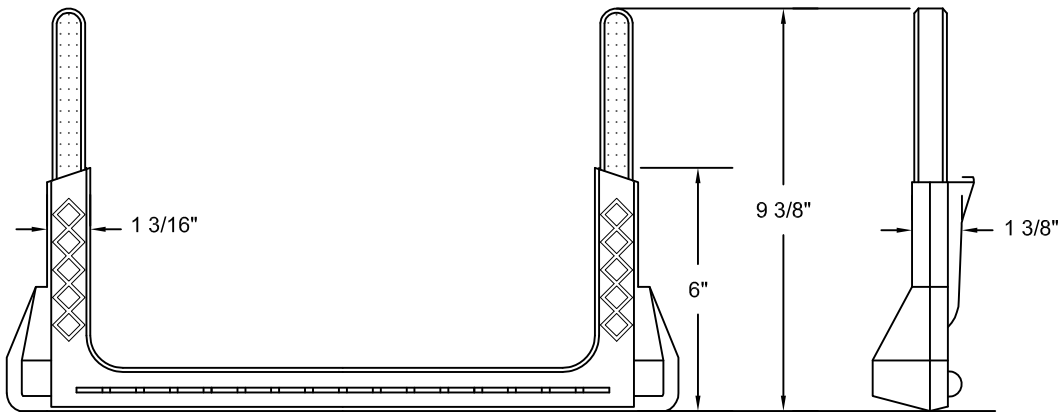

COPOLMER POLYPROPYLENE PLASTIC

1/2" GRADE 60
STEEL REINFORCEMENT

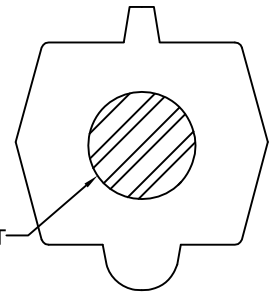

COPOLYMER POLYPROPYLENE MANHOLE STEP (ASTM C-478)

PLASTIC

MANHOLE STEPS ARE TO BE MADE OF COPOLYMER POLYPROPYLENE.

THE COPOLYMER POLYPROPYLENE TO CONFORM TO A.S.T.M. D-4141-95B PPO344B33534Z02
(THE PREVIOUS STANDARD OF A.S.T.M. D-4101-92B, WAS REPLACED BY D-4101-95B.

STEEL REINFORCING BAR

THE STEEL TO BE USED IN MANUFACTURING OF THIS PRODUCT TO BE A DEFORMED 1/2" REINFORCING ROD.
THIS MATERIAL TO BE GRADE 60 AND CONFORM TO ALL THE REQUIREMENTS OF ASTM A-615.

UPPER DUBLIN TOWNSHIP STANDARD DETAIL
COPOLYMER POLYPROPYLENE
MANHOLE STEP



DATE 10-2013

NOT TO SCALE

DR312

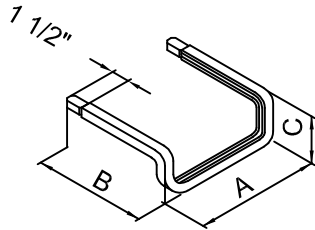

PRECAST M.H. (TYPE #1)

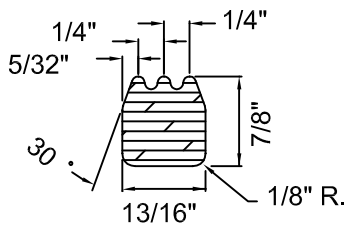

TYPICAL CROSS SECTION
ON ALL STEPS

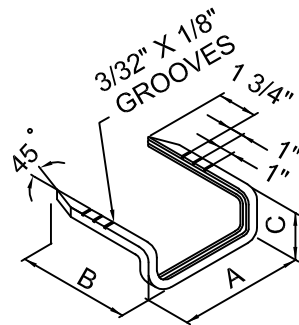

PRECAST M.H. (TYPE #2)

APPLICATION	DIMENSION (IN)		
	A	B	C
CAST IN PLACE WALLS	17-3/4	13-13/16	3-3/4
PRECAST M.H. (TYPE #1)	13-3/4	10	3-3/4
PRECAST M.H. (TYPE #2)	13-3/4	11	3-3/4

UPPER DUBLIN TOWNSHIP STANDARD DETAIL
DROP FRONT ALUMINUM MANHOLE STEP

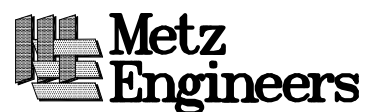

DATE 10-2013

NOT TO SCALE

DR313

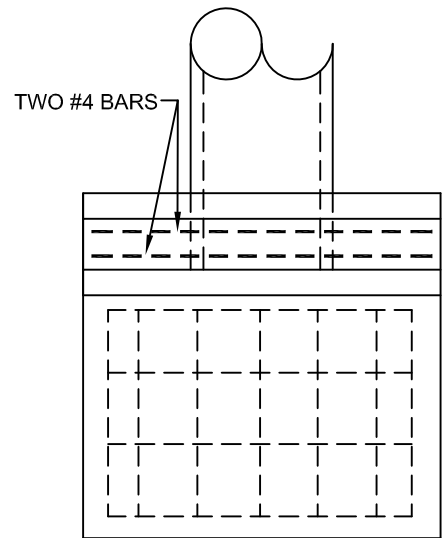
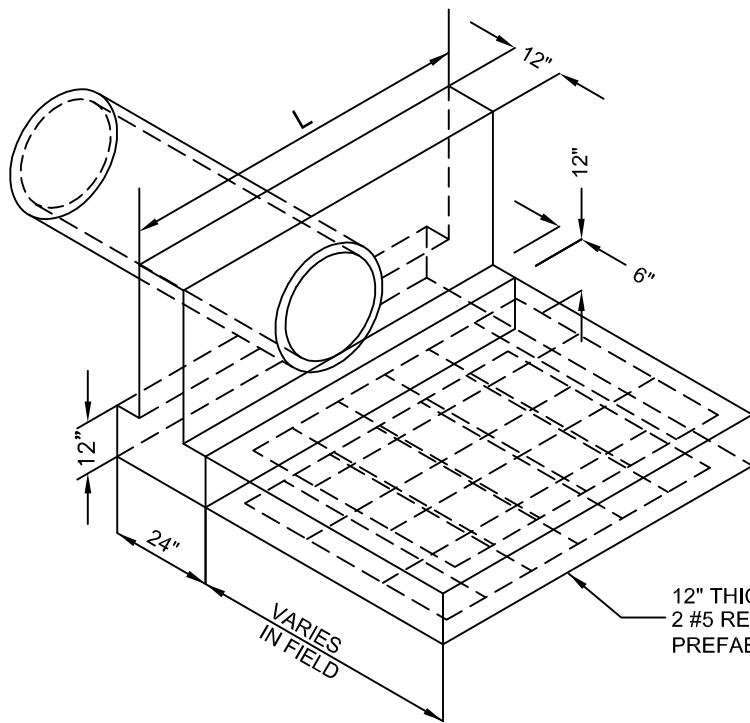

12" THICK SPLASH PAD W/
2 #5 REBAR MATS, 3" FROM TOP AND BOTTOM
PREFABED OR POURED IN FIELD

NOTE:
ALL HEADWALLS AND ENDWALLS
TO BE SET ON 6" 2B CLEAN
STONE (AASHTO #57)

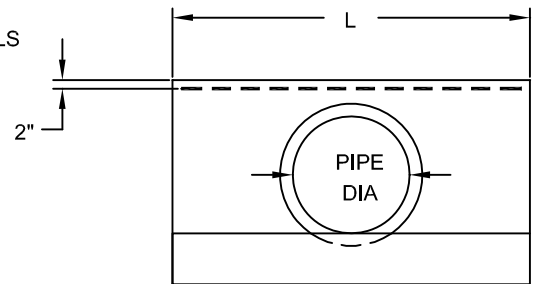
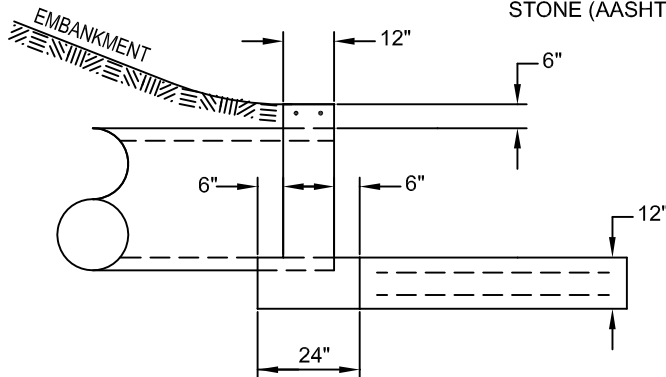

PIPE DIA	L
15", 18", & 21"	5'
24" & 27"	7'
30" & 33"	9'

PAD:

POURED IN FIELD: REBAR MATS MUST BE DOWEL PINNED AND SECURED INTO ENDWALL WITH NONSHRINK GROUT. CONCRETE TO BE CLASS AA MODIFIED DESIGN COMPRESSIVE STRENGTH (4000 PSI), 4" SLUMP, AIR-ENTRAINED (6%)

PRECAST: FOLLOW PENNDOT 408 CURRENT EDITION.

NOTES:

- 1) PROVIDE MATERIALS AND WORKMANSHIP IN ACCORDANCE WITH THE REQUIREMENTS OF PENNDOT PUB. 408 CURRENT EDITION SEC. 605 AND SEC. 714.
- 2) CONCRETE TO BE CLASS AA MODIFIED DESIGN COMPRESSIVE STRENGTH (4000 P.S.I.).
- 3) PROVIDE REINFORCEMENT IN ACCORDANCE WITH PENNDOT PUB. 408 CURRENT EDITION, SEC. 709.
- 4) CHAMFER ALL EXPOSED EDGES.

UPPER DUBLIN TOWNSHIP STANDARD DETAIL
TYPE D ENDWALL



DATE 10-2013

NOT TO SCALE

DR314

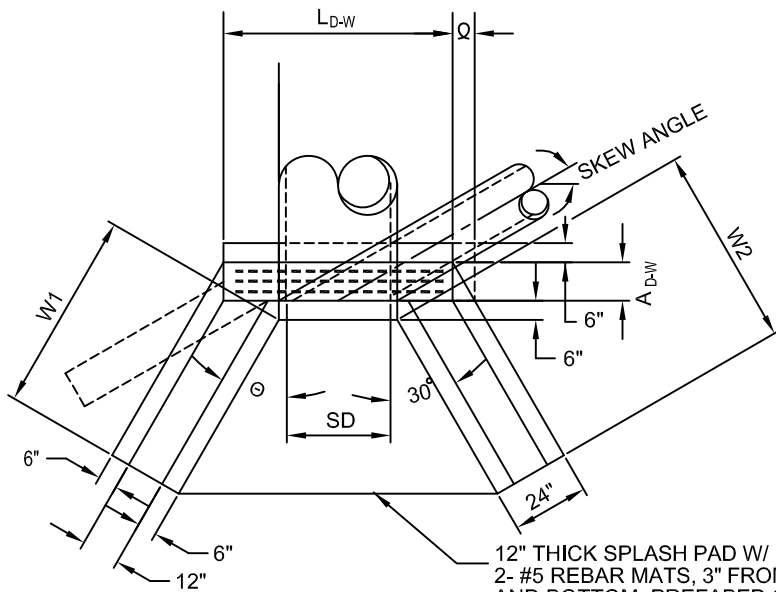

NOTE:
ALL HEADWALLS AND ENDWALLS
TO BE SET ON 6" 2B CLEAN
STONE (AASHTO #57)

12" THICK SPLASH PAD W/
2- #5 REBAR MATS, 3" FROM TOP
AND BOTTOM. PREFABED OR POURED
IN FIELD. (SEE DETAIL)

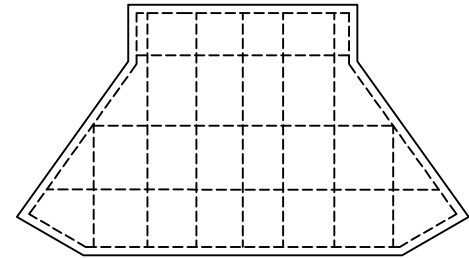

SPLASH PAD DETAIL

NOTE: 2- #5 REBAR MATS, 3" FROM TOP AND BOTTOM

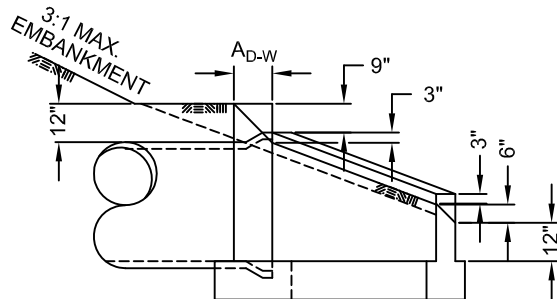

PAD:
POURED IN FIELD: REBAR MATS MUST BE DOWEL PINNED WITH #5
REBAR @12" C. TO C. (TYP) AND SECURED INTO ENDWALL WITH
NON SHRINK GROUT. CONCRETE TO BE CLASS AA MODIFIED DESIGN
COMPRESSIVE STRENGTH (4000 PSI), 4" SLUMP, AIR-ENTRAINED (6%).
PRECAST: FOLLOW PENNDOT 408 CURRENT EDITION.

NOTES:

- 1) PROVIDE MATERIALS AND WORKMANSHIP IN ACCORDANCE WITH THE REQUIREMENTS OF PENNDOT PUB. 408 CURRENT EDITION SEC. 605 AND SEC. 714.
- 2) CONCRETE TO BE CLASS AA MODIFIED DESIGN COMPRESSIVE STRENGTH (4000 PSI)
- 3) PROVIDE REINFORCEMENT IN ACCORDANCE WITH PENNDOT PUB. 408 CURRENT EDITION, SEC. 709.
- 4) CHAMFER ALL EXPOSED EDGES.

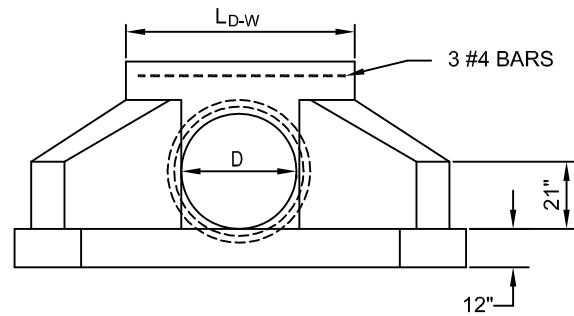

3:1 EMBANKMENT SLOPE			
PIPE DIAMETER	SKEW ANGLE = 90° TO 60°		
	Θ = 30°		
D _{D-W} (IN.)	L _{D-W} (FT.)	Q (FT.)	W1 (FT.)
18	4.0	0	1.7
24	4.6	0	3.5
30	5.2	0	5.2
36	5.8	0	6.9
42	6.3	0	8.7
48	6.9	0	10.4
54	7.5	0	12.1
60	8.1	0	13.8
72	9.2	0	17.3

NOTE: FOR ALL OTHER SKEW ANGLES AND Θ GREATER THAN 30° AND FOR ALL OTHER SLOPES, REFER TO PENNDOT RC STANDARDS RC-31M SHEET 2 OF 2 CURRENT EDITION FOR FORMULAS FOR PROPER DESIGN.

UPPER DUBLIN TOWNSHIP STANDARD DETAIL
TYPE D-W ENDWALL
3:1 SLOPE



DATE 10-2013

NOT TO SCALE

DR315

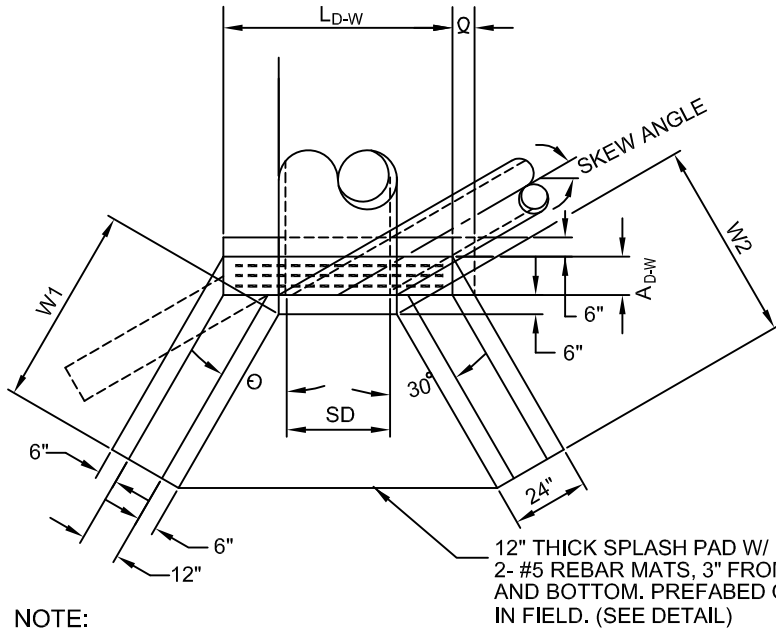

NOTE:
ALL HEADWALLS AND ENDWALLS
TO BE SET ON 6" 2B CLEAN
STONE (AASHTO #57)

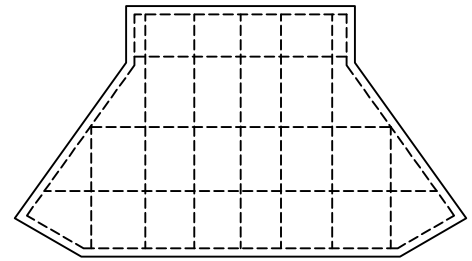

SPLASH PAD DETAIL

NOTE: 2- #5 REBAR MATS, 3" FROM TOP AND BOTTOM

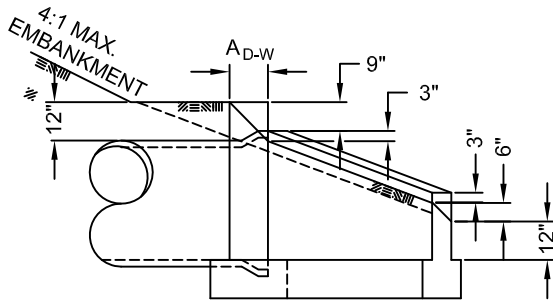

PAD:
POURED IN FIELD: REBAR MATS MUST BE DOWEL PINNED WITH #5
REBAR @12" C. TO C. (TYP) AND SECURED INTO ENDWALL WITH
NON SHRINK GROUT. CONCRETE TO BE CLASS AA MODIFIED DESIGN
COMPRESSIVE STRENGTH (4000 PSI), 4" SLUMP, AIR-ENTRAINED (6%).
PRECAST: FOLLOW PENNDOT 408 CURRENT EDITION.

- NOTES:
- 1) PROVIDE MATERIALS AND WORKMANSHIP IN ACCORDANCE WITH THE REQUIREMENTS OF PENNDOT PUB. 408 CURRENT EDITION SEC. 605 AND SEC. 714.
 - 2) CONCRETE TO BE CLASS AA MODIFIED DESIGN COMPRESSIVE STRENGTH (4000 PSI).
 - 3) PROVIDE REINFORCEMENT IN ACCORDANCE WITH PENNDOT PUB. 408 CURRENT EDITION, SEC. 709.
 - 4) CHAMFER ALL EXPOSED EDGES.

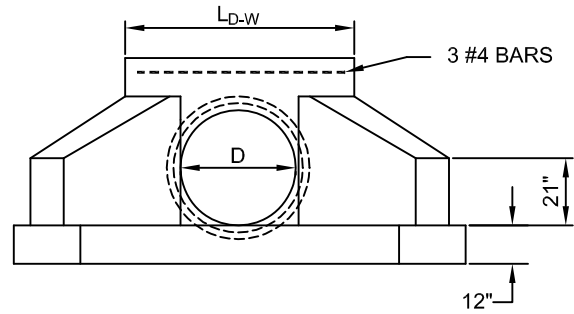

4:1 EMBANKMENT SLOPE			
PIPE DIAMETER	SKEW ANGLE = 90° TO 60° Θ = 30°		
D _{D-W} (IN.)	L _{D-W} (FT.)	Ω (FT.)	W1 (FT.)
18	4.0	0	2.3
24	4.6	0	4.6
30	5.2	0	6.9
36	5.8	0	9.2
42	6.3	0	11.6
48	6.9	0	13.9
54	7.5	0	16.2
60	8.1	0	18.5
72	9.2	0	23.1

NOTE: FOR ALL OTHER SKEW ANGLES AND Θ GREATER THAN 30° AND FOR ALL OTHER SLOPES, REFER TO PENNDOT RC STANDARDS RC-31M SHEET 2 OF 2 CURRENT EDITION FOR FORMULAS FOR PROPER DESIGN.

**UPPER DUBLIN TOWNSHIP STANDARD DETAIL
TYPE D-W ENDWALL
4:1 SLOPE**



DATE 10-2013

NOT TO SCALE

DR316

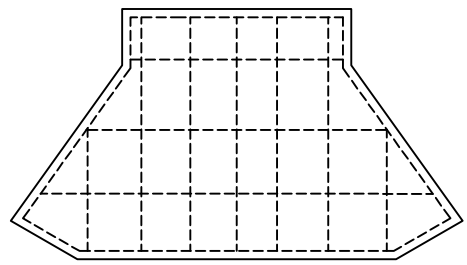
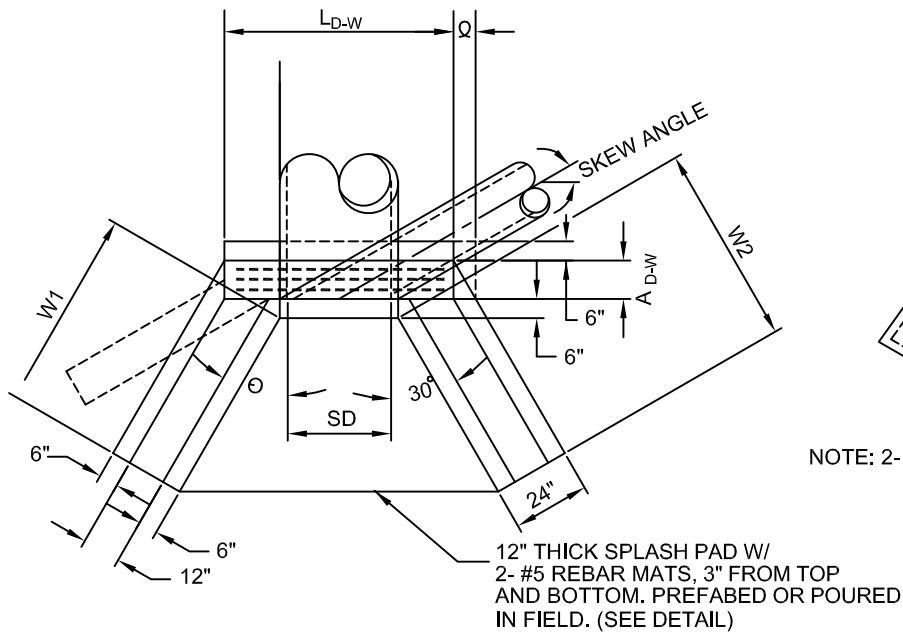

SPLASH PAD DETAIL
NOTE: 2- #5 REBAR MATS, 3" FROM TOP AND BOTTOM

NOTE:
ALL HEADWALLS AND ENDWALLS
TO BE SET ON 6" 2B CLEAN
STONE (AASHTO #57)

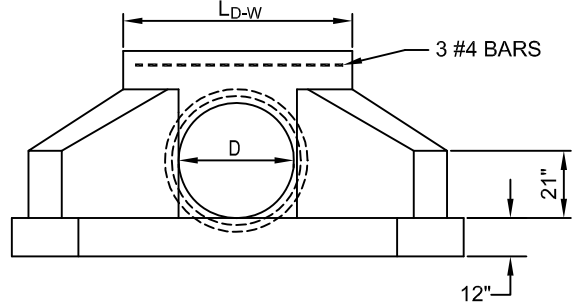
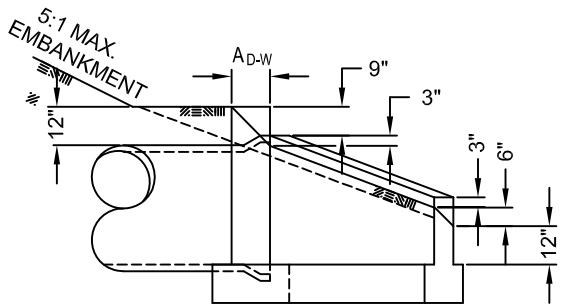

PAD:
POURED IN FIELD: REBAR MATS MUST BE DOWEL PINNED WITH #5 REBAR @12" C. TO C. (TYP) AND SECURED INTO ENDWALL WITH NON SHRINK GROUT. CONCRETE TO BE CLASS AA MODIFIED DESIGN COMPRESSIVE STRENGTH (4000 PSI), 4" SLUMP, AIR-ENTRAINED (6%).
PRECAST: FOLLOW PENNDOT 408 CURRENT EDITION.

- NOTES:
- 1) PROVIDE MATERIALS AND WORKMANSHIP IN ACCORDANCE WITH THE REQUIREMENTS OF PENNDOT PUB. 408 CURRENT EDITION SEC. 605 AND SEC. 714.
 - 2) CONCRETE TO BE CLASS AA MODIFIED DESIGN COMPRESSIVE STRENGTH (4000 PSI).
 - 3) PROVIDE REINFORCEMENT IN ACCORDANCE WITH PENNDOT PUB. 408 CURRENT EDITION, SEC. 709.
 - 4) CHAMFER ALL EXPOSED EDGES.

5:1 EMBANKMENT SLOPES			
PIPE DIAMTER	SKEW ANGLE = 90° TO 60°		
	θ = 30°		
D _{D-W} (IN.)	L _{D-W} (FT.)	Ω (FT.)	W1 (FT.)
18	4.0	0	2.9
24	4.6	0	5.8
30	5.2	0	8.7
36	5.8	0	11.6
42	6.3	0	14.4
48	6.9	0	17.3
54	7.5	0	20.2
60	8.1	0	23.1
72	9.2	0	28.9

NOTE: FOR ALL OTHER SKEW ANGLES AND θ GREATER THAN 30° AND FOR ALL OTHER SLOPES, REFER TO PENNDOT RC STANDARDS RC-31M SHEET 2 OF 2 CURRENT EDITION FOR FORMULAS FOR PROPER DESIGN.

UPPER DUBLIN TOWNSHIP STANDARD DETAIL
TYPE D-W ENDWALL
5:1 SLOPE



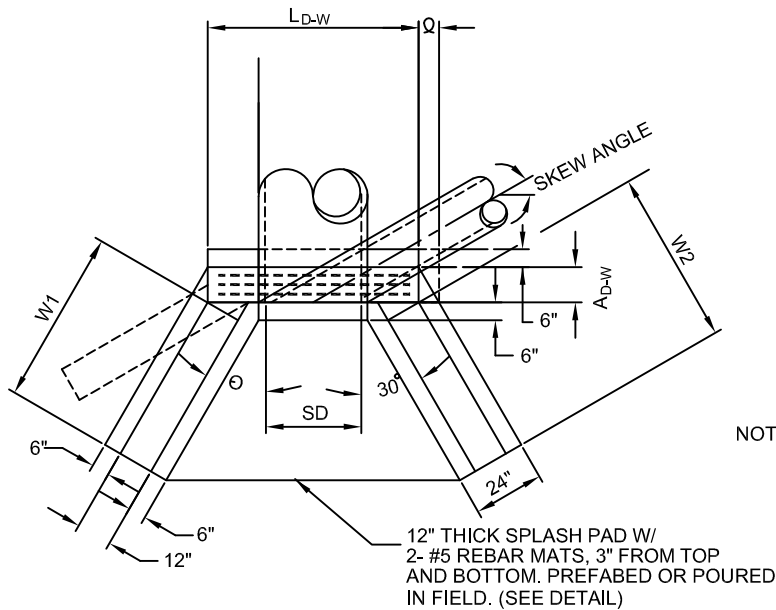

NOTE:
ALL HEADWALLS AND ENDWALLS TO BE SET ON 6" 2B CLEAN STONE (AASHTO #57)

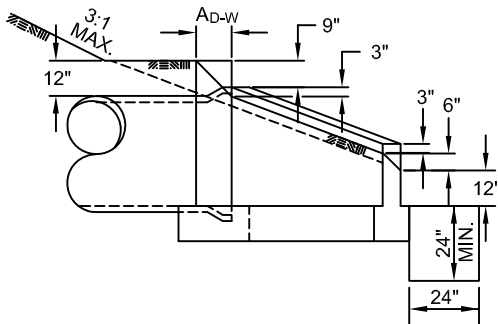

PAD:
POURED IN FIELD: REBAR MATS MUST BE DOWEL PINNED WITH #5 REBAR @12" C. TO C. (TYP) AND SECURED INTO ENDWALL WITH NON SHRINK GROUT. CONCRETE TO BE CLASS AA MODIFIED DESIGN COMPRESSIVE STRENGTH (4000 PSI), 4" SLUMP, AIR-ENTRAINED (6%).
PRECAST: FOLLOW PENNDOT 408 CURRENT EDITION.

- NOTES:
1. PROVIDE MATERIALS AND WORKMANSHIP IN ACCORDANCE WITH THE REQUIREMENTS OF PENNDOT PUBLICATION 408 CURRENT EDITION SEC. 605 AND SEC. 714.
 2. CONCRETE TO BE CLASS AA MODIFIED DESIGN COMPRESSIVE STRENGTH (4000 PSI).
 3. PROVIDE REINFORCEMENT IN ACCORDANCE WITH PENNDOT PUBLICATION 408 CURRENT EDITION, SEC. 709.
 4. CUTOFF WALL IS REQUIRED TO BE DOWEL PINNED INTO ENDWALL BASE/SPLASH PAD, #5 REBAR 12" C. TO C. (TYP.).

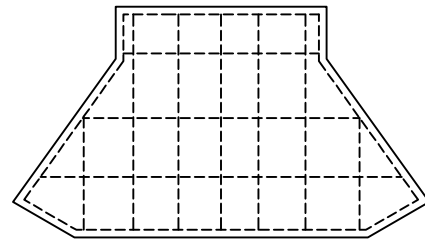

SPLASH PAD DETAIL
NOTE: 2- #5 REBAR MATS, 3" FROM TOP AND BOTTOM

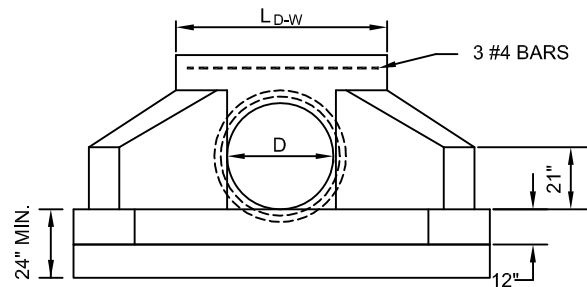

3:1 EMBANKMENT SLOPE				
PIPE DIAMETER	SKEW ANGLE = 90° TO 60° Θ = 30°			
	D D-W (IN.)	L D-W (FT.)	Ω (FT.)	W1 (FT.)
18	4.0	0	1.7	
24	4.6	0	3.5	
30	5.2	0	5.2	
36	5.8	0	6.9	
42	6.3	0	8.7	
48	6.9	0	10.4	
54	7.5	0	12.1	
60	8.1	0	13.8	
72	9.2	0	17.3	

NOTE: FOR ALL OTHER SKEW ANGLES AND Θ GREATER THAN 30° AND FOR ALL OTHER SLOPES, REFER TO PENNDOT RC STANDARDS RC-31M SHEET 2 OF 2 CURRENT EDITION FOR FORMULAS FOR PROPER DESIGN.

UPPER DUBLIN TOWNSHIP STANDARD DETAIL
TYPE D-W HEADWALL W/ CUTOFF WALL, 3:1 SLOPE
FOR UPSTREAM HEADWALLS



DATE 10-2013

NOT TO SCALE

DR318

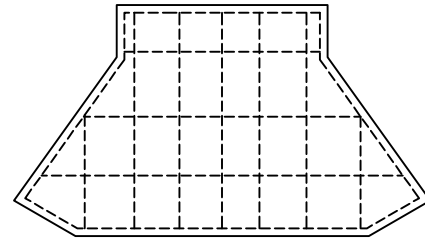
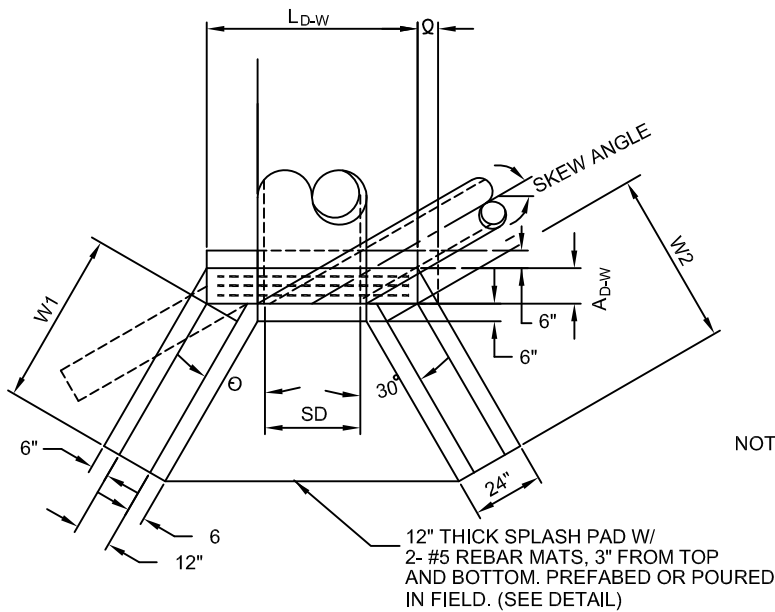

SPLASH PAD DETAIL
NOTE: 2- #5 REBAR MATS, 3" FROM TOP AND BOTTOM

NOTE:
ALL HEADWALLS AND ENDWALLS TO BE SET ON 6" 2B CLEAN STONE (AASHTO #57)

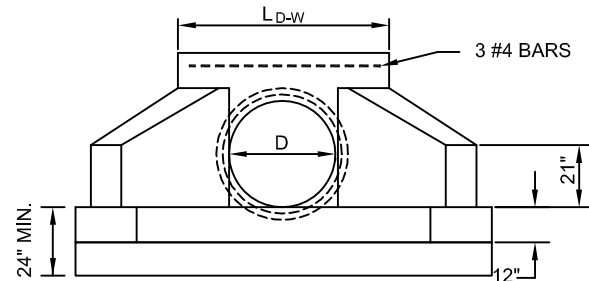
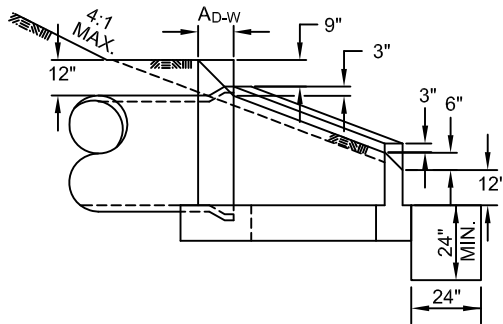

PAD:
POURED IN FIELD: REBAR MATS MUST BE DOWEL PINNED WITH #5 REBAR @12" C. TO C. (TYP) AND SECURED INTO ENDWALL WITH NON SHRINK GROUT. CONCRETE TO BE CLASS AA MODIFIED DESIGN COMPRESSIVE STRENGTH (4000 PSI), 4" SLUMP, AIR-ENTRAINED (6%).
PRECAST: FOLLOW PENNDOT 408 CURRENT EDITION.

- NOTES:
1. PROVIDE MATERIALS AND WORKMANSHIP IN ACCORDANCE WITH THE REQUIREMENTS OF PENNDOT PUBLICATION 408 CURRENT EDITION SEC. 605 AND SEC. 714.
 2. CONCRETE TO BE CLASS AA MODIFIED DESIGN COMPRESSIVE STRENGTH (4000 PSI).
 3. PROVIDE REINFORCEMENT IN ACCORDANCE WITH PENNDOT PUBLICATION 408 CURRENT EDITION, SEC. 709.
 4. CUTOFF WALL IS REQUIRED TO BE DOWEL PINNED INTO ENDWALL BASE/SPLASH PAD, #5 REBAR 12" C. TO C. (TYP.).

4:1 EMBANKMENT SLOPE				
PIPE DIAMETER	SKEW ANGLE = 90° TO 60° Θ = 30°			
	D D-W (IN.)	L D-W (FT.)	Ω (FT.)	W1 (FT.)
18	4.0	0	2.3	
24	4.6	0	4.6	
30	5.2	0	6.9	
36	5.8	0	9.2	
42	6.3	0	11.6	
48	6.9	0	13.9	
54	7.5	0	16.2	
60	8.1	0	18.5	
72	9.2	0	23.1	

NOTE: FOR ALL OTHER SKEW ANGLES AND Θ GREATER THAN 30° AND FOR ALL OTHER SLOPES, REFER TO PENNDOT RC STANDARDS RC-31M SHEET 2 OF 2 CURRENT EDITION FOR FORMULAS FOR PROPER DESIGN.

UPPER DUBLIN TOWNSHIP STANDARD DETAIL
TYPE D-W HEADWALL W/ CUTOFF WALL, 4:1 SLOPE
FOR UPSTREAM HEADWALLS



DATE 10-2013

NOT TO SCALE

DR319

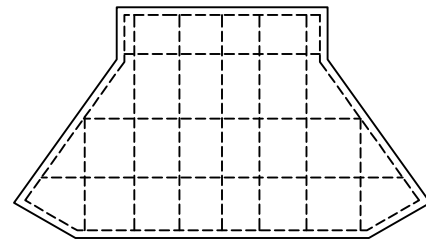
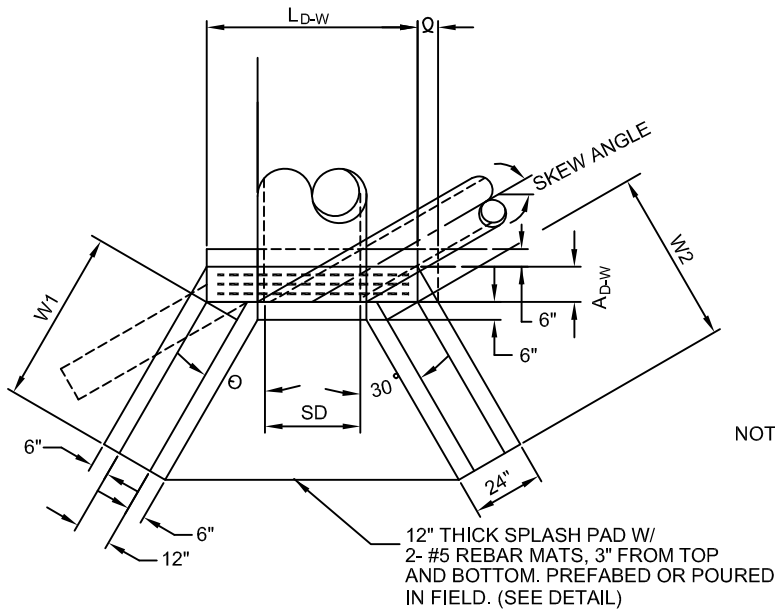

SPLASH PAD DETAIL

NOTE: 2- #5 REBAR MATS, 3" FROM TOP AND BOTTOM

NOTE:
ALL HEADWALLS AND ENDWALLS TO BE SET ON 6" 2B CLEAN STONE (AASHTO #57)

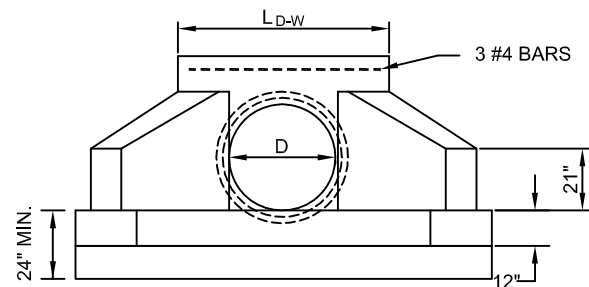
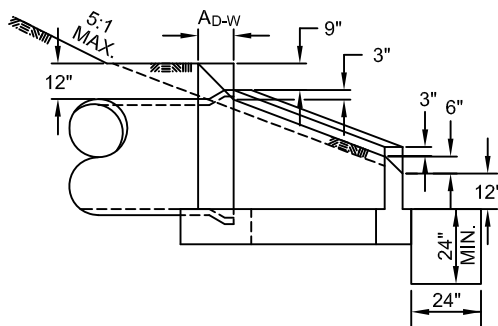

PAD:
POURED IN FIELD: REBAR MATS MUST BE DOWEL PINNED WITH #5 REBAR @12" C. TO C. (TYP) AND SECURED INTO ENDWALL WITH NON SHRINK GROUT. CONCRETE TO BE CLASS AA MODIFIED DESIGN COMPRESSIVE STRENGTH (4000 PSI), 4" SLUMP, AIR-ENTRAINED (6%). PRECAST: FOLLOW PENNDOT 408 CURRENT EDITION.

NOTES:

1. PROVIDE MATERIALS AND WORKMANSHIP IN ACCORDANCE WITH THE REQUIREMENTS OF PENNDOT PUBLICATION 408 CURRENT EDITION SEC. 605 AND SEC. 714.
2. CONCRETE TO BE CLASS AA MODIFIED DESIGN COMPRESSIVE STRENGTH (4000 PSI).
3. PROVIDE REINFORCEMENT IN ACCORDANCE WITH PENNDOT PUBLICATION 408 CURRENT EDITION, SEC. 709.
4. CUTOFF WALL IS REQUIRED TO BE DOWEL PINNED INTO ENDWALL BASE/SPLASH PAD, #5 REBAR 12" C. TO C. (TYP.).

5:1 EMBANKMENT SLOPES			
PIPE DIAMETER	SKEW ANGLE = 90° TO 60° Θ = 30°		
D D-W (IN.)	L D-W (FT.)	Ω (FT.)	W1 (FT.)
18	4.0	0	2.9
24	4.6	0	5.8
30	5.2	0	8.7
36	5.8	0	11.6
42	6.3	0	14.4
48	6.9	0	17.3
54	7.5	0	20.2
60	8.1	0	23.1
72	9.2	0	28.9

NOTE: FOR ALL OTHER SKEW ANGLES AND Θ GREATER THAN 30° AND FOR ALL OTHER SLOPES, REFER TO PENNDOT RC STANDARDS RC-31M SHEET 2 OF 2 CURRENT EDITION FOR FORMULAS FOR PROPER DESIGN.

**UPPER DUBLIN TOWNSHIP STANDARD DETAIL
TYPE D-W HEADWALL W/ CUTOFF WALL, 5:1 SLOPE
FOR UPSTREAM HEADWALLS**



DATE 10-2013

NOT TO SCALE

DR320

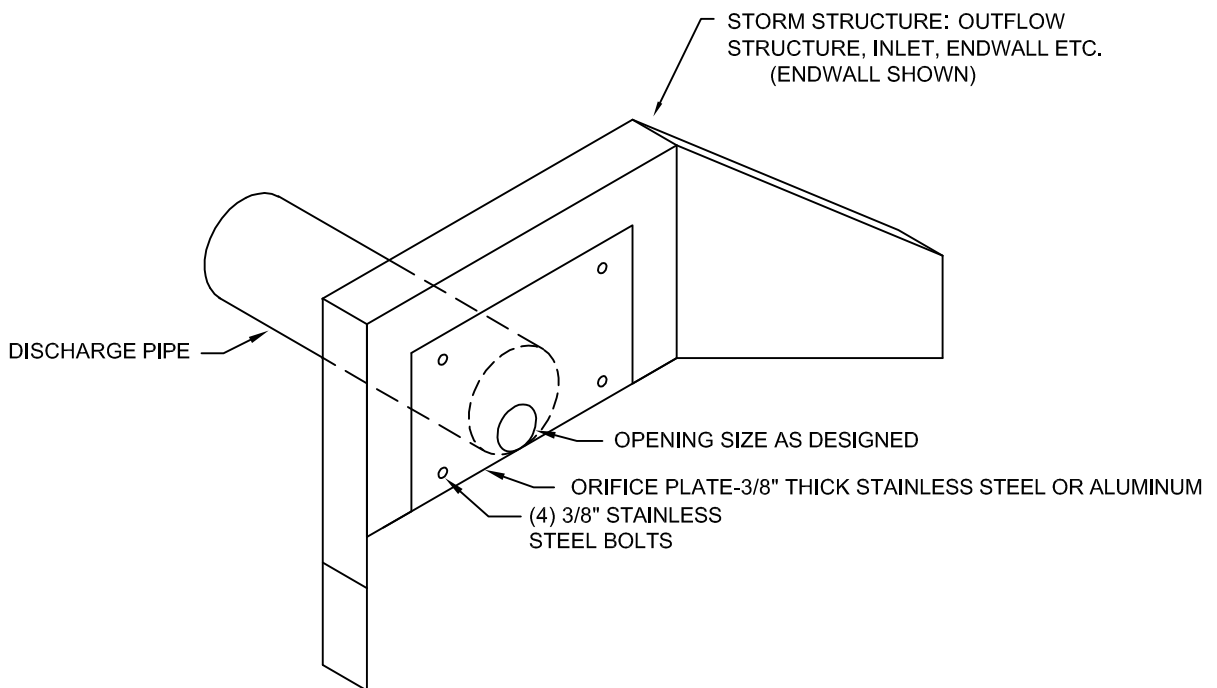
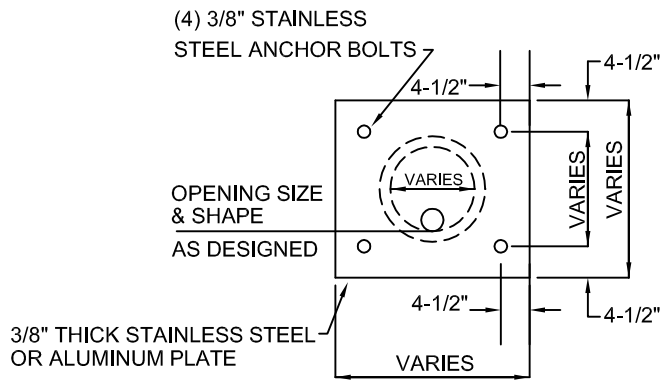

UPPER DUBLIN TOWNSHIP STANDARD DETAIL
ORIFICE PLATE FOR
DISCHARGE CONTROL



DATE 10-2013

NOT TO SCALE

DR321

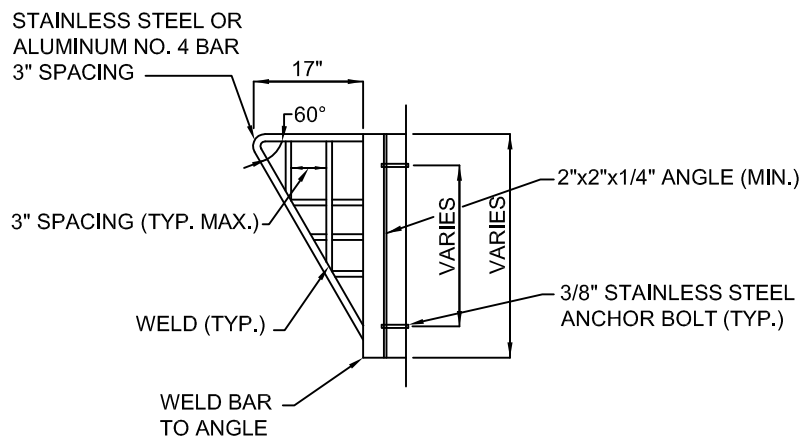
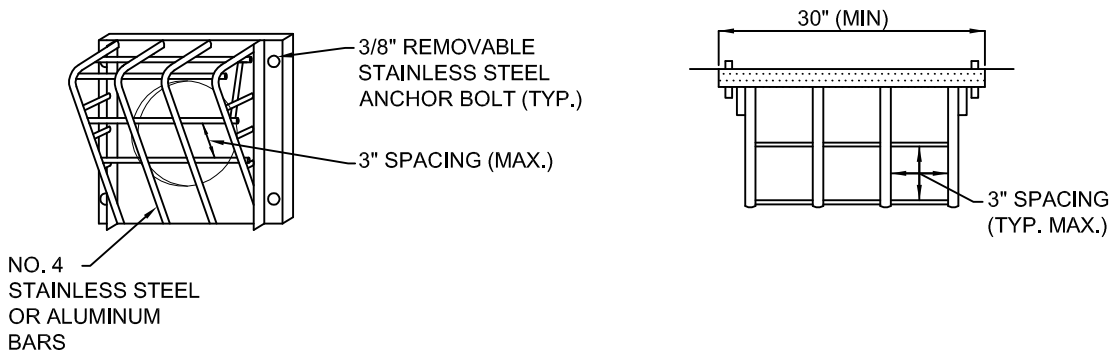

**UPPER DUBLIN TOWNSHIP STANDARD DETAIL
PERMANENT TRASH RACK DETAIL**



DATE 10-2013

NOT TO SCALE

DR322

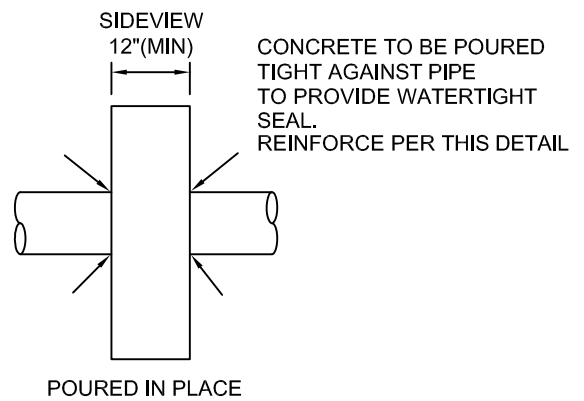
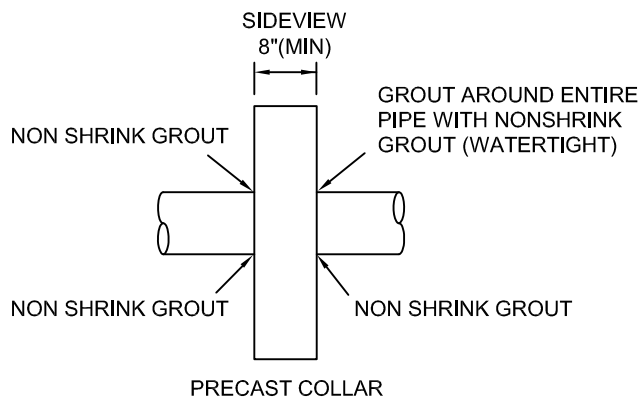
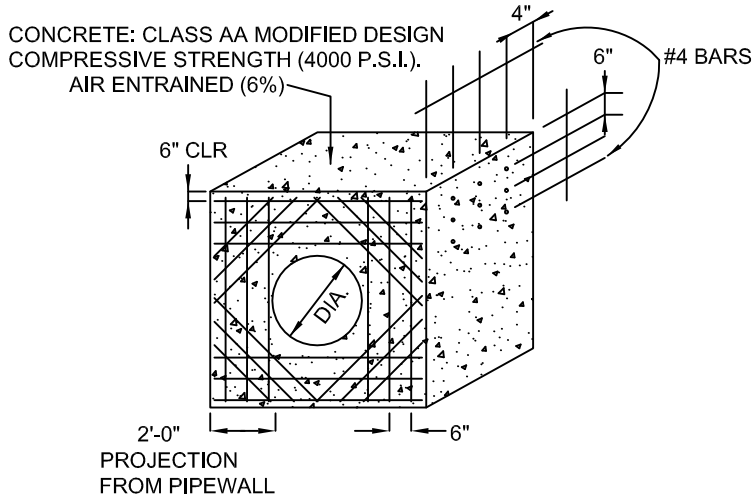

NOTE:
 1. PRECAST COLLAR FOR PIPE DIAMETERS 12" TO 24" TO BE 8" THICK (MIN)
 FOR PIPE DIAMETERS 27" TO 48" INCREASE THICKNESS TO 12" THICK(MIN).

UPPER DUBLIN TOWNSHIP STANDARD DETAIL
 REINFORCED PRECAST
 CONCRETE ANTI-SEEP COLLAR



DATE 10-2013

NOT TO SCALE

DR323

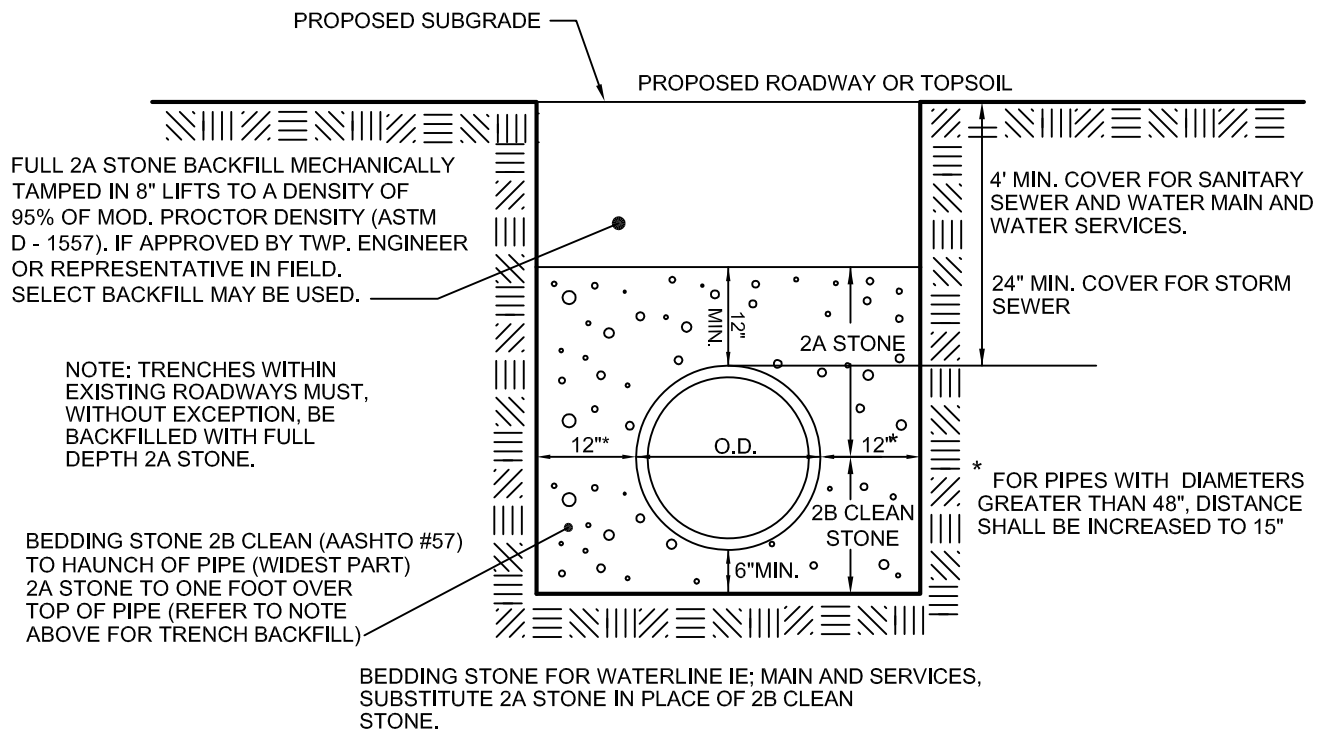

NOTE:
 ALL GAS, ELECTRIC & TELECOMMUNICATION LINES, AND WATER SERVICE TRENCHES WITHIN EXISTING ROADWAYS, PROPOSED ROADWAYS, ALL RIGHT OF WAYS, BIKETRAIL EASEMENTS, PROPOSED DRIVEWAYS, APRONS AND SIDEWALKS MUST, WITHOUT EXCEPTION, BE BACKFILLED WITH FULL DEPTH 2A STONE AFTER TOP SCREENING.
 ALL UTILITY TRENCHES MUST BE COMPACTED (MECHANICALLY TAMPED) IN 8" LIFTS.

UPPER DUBLIN TOWNSHIP STANDARD DETAIL
TYPICAL TRENCH DETAIL



DATE 10-2013

NOT TO SCALE

DR324

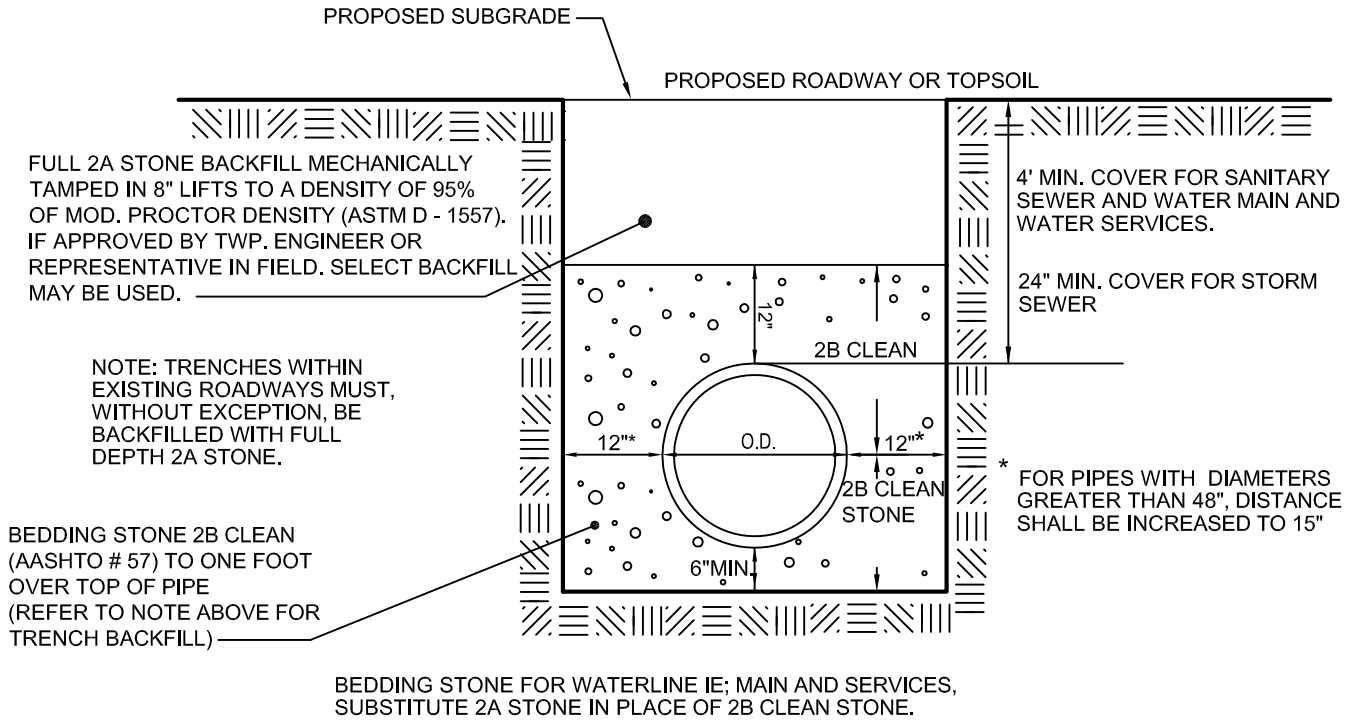

NOTE:
 ALL GAS, ELECTRIC & TELECOMMUNICATION LINES, AND WATER SERVICE TRENCHES WITHIN EXISTING ROADWAYS, PROPOSED ROADWAYS, ALL RIGHT OF WAYS, BIKETRAIL EASEMENTS, PROPOSED DRIVEWAYS, APRONS AND SIDEWALKS MUST, WITHOUT EXCEPTION, BE BACKFILLED WITH FULL DEPTH 2A STONE AFTER TOP SCREENING. ALL UTILITY TRENCHES MUST BE COMPACTED (MECHANICALLY TAMPED) IN 8" LIFTS.

**UPPER DUBLIN TOWNSHIP STANDARD DETAIL
 TYPICAL TRENCH DETAIL CIRCULAR
 H.D.P.E. STORM SEWER**



DATE 10-2013

NOT TO SCALE

DR325

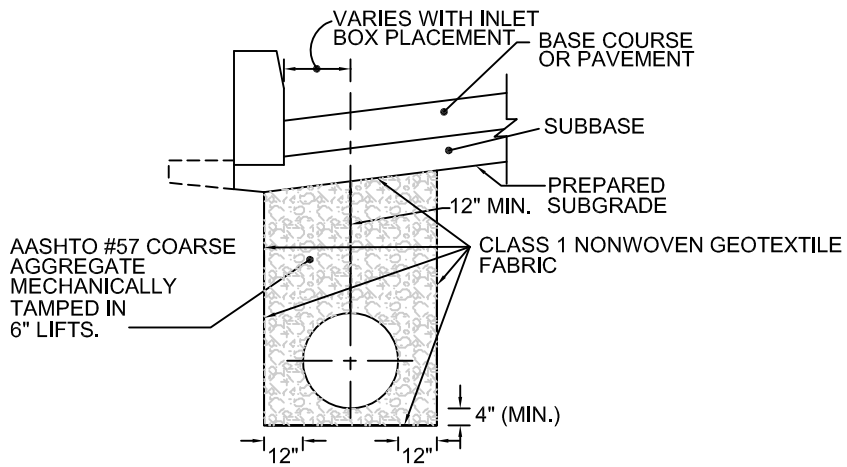

NOTE:

1. PROVIDE MATERIALS AND CONSTRUCTION MEETING THE REQUIREMENTS OF PENNDOT PUBLICATION 408, CURRENT EDITION AND SECTION 604 FOR COMBINATION STORM SEWER AND UNDERDRAIN.
2. PIPE JOINTS (OPEN JOINT).

UPPER DUBLIN TOWNSHIP STANDARD DETAIL
 COMBINATION STORM SEWER AND
 UNDERDRAIN REINFORCED
 CONCRETE PIPE



DATE

10-2013

NOT TO SCALE

DR326

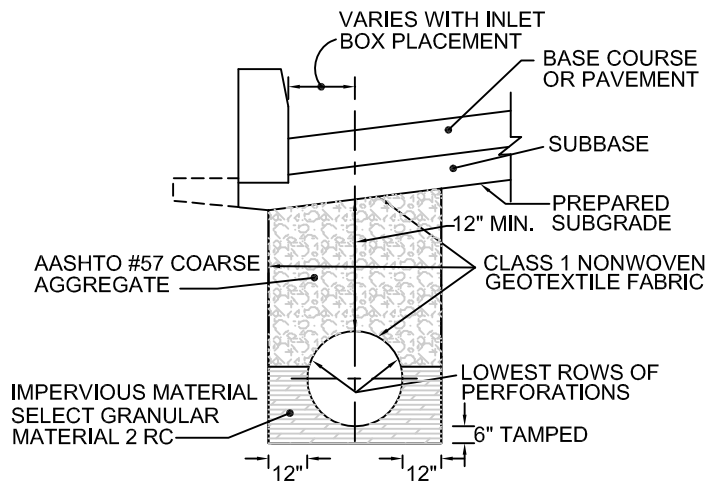

NOTE:

1. PROVIDE MATERIALS AND CONSTRUCTION MEETING THE REQUIREMENTS OF PENNDOT PUBLICATION 408, CURRENT EDITION AND SECTION 604 FOR COMBINATION STORM SEWER AND UNDERDRAIN.
2. PLACE SELECT GRANULAR MATERIAL (2RC), MECHANICALLY TAMPED IN LAYERS 6" THICK TO A DENSITY OF 95% OF MODIFIED PROCTOR DENSITY (ASTM D-1557).
3. PLACE NO. #57 COARSE AGGREGATE, TAMPED IN LAYERS 6" THICK STARTING PIPE AT THE LOWEST ROWS OF PERFORATIONS. PLACE GROUPS OF PERFORATIONS SYMMETRICALLY ABOUT THE VERTICAL CENTER LINE.

**UPPER DUBLIN TOWNSHIP STANDARD DETAIL
COMBINATION STORM SEWER
AND UNDERDRAIN HDPE PIPE**



DATE

10-2013

NOT TO SCALE

DR327

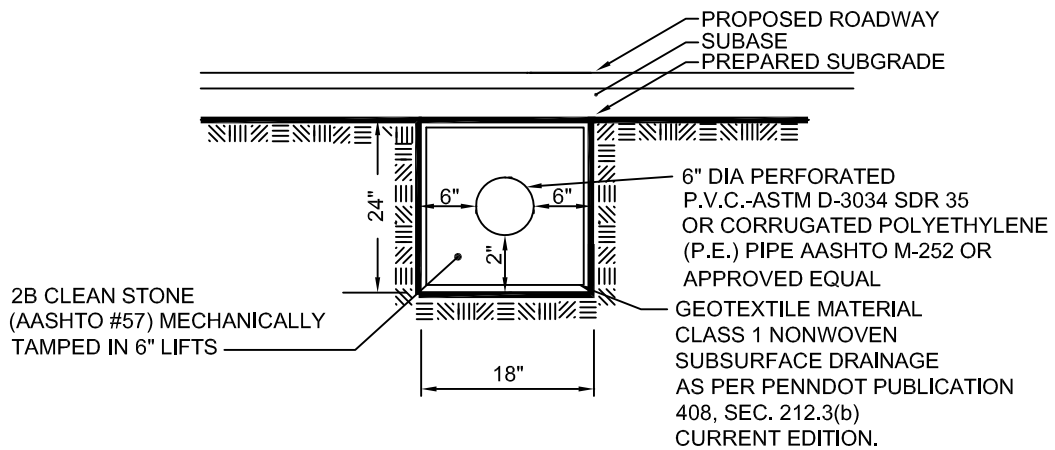

NOTE:
1. PROVIDE MATERIALS AND
CONSTRUCTION IN ACCORDANCE
WITH PENNDOT PUBLICATION
408, CURRENT EDITION AND AS
MODIFIED HEREIN.

UPPER DUBLIN TOWNSHIP STANDARD DETAIL
PERFORATED UNDER-DRAIN



DATE

10-2013

NOT TO SCALE

DR328

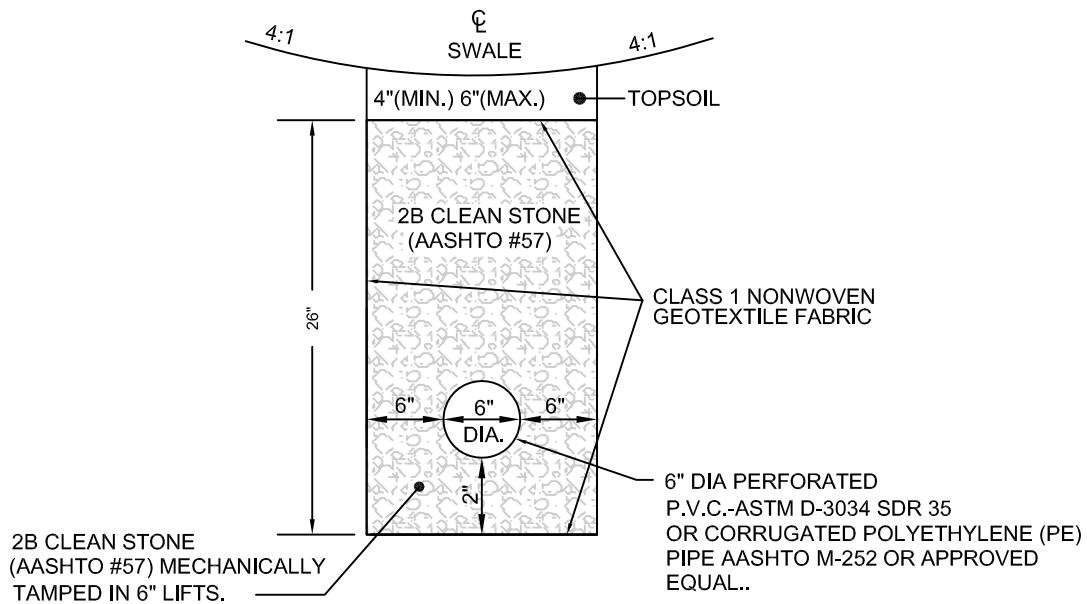

NOTE:

- 1) PROVIDE MATERIALS AND CONSTRUCT IN ACCORDANCE WITH PENNDOT PUBLICATION 408 CURRENT EDITION AND AS MODIFIED HEREIN.
- 2) U-DRAIN REQUIRED IN ALL SWALES WITH LESS THAN 2% LONGITUDINAL SLOPE AND AS DIRECTED BY TOWNSHIP ENGINEER OR HIS/HER REPRESENTATIVE IN THE FIELD.

**UPPER DUBLIN TOWNSHIP STANDARD DETAIL
PERFORATED UNDERDRAIN
SWALES AND OUTSIDE OF ROADWAY**



DATE

10-2013

NOT TO SCALE

DR329

REFER TO E&S PLANS AND DETAILS
FOR REQUIRED E&S CONTROLS
AS APPROVED BY DEP AND MCCD.

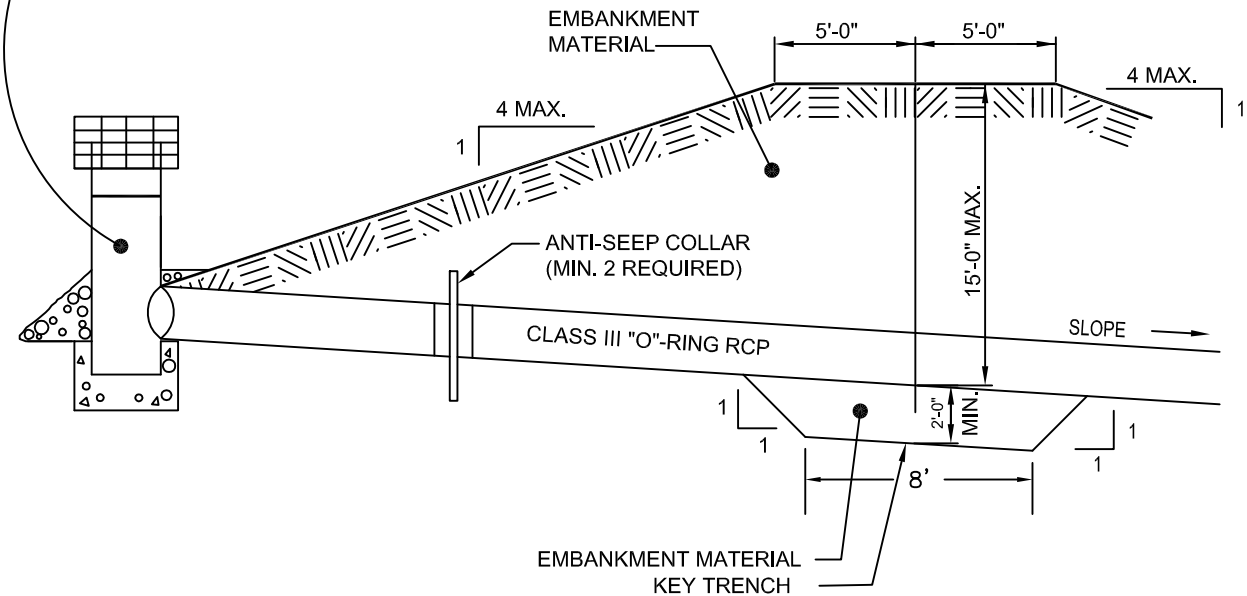

NOTES:

- 1) EMBANKMENT AND KEY WAY MATERIAL AS WELL AS BACKFILL MATERIAL AROUND ENTIRE OUTFALL PIPE THROUGH BERM AND ANTI SEEP COLLARS TO BE TYPE CL OR ML SOILS, CLAYSOIL.
- 2) EMBANKMENT AND KEY WAY MATERIAL AS WELL AS BACKFILL MATERIAL AROUND ENTIRE OUTFALL PIPE THROUGH BERM AND ANTI SEEP COLLARS SHOULD CONTAIN SUFFICIENT MOISTURE SO THAT IT CAN BE FORMED BY HAND INTO A BALL WITHOUT CRUMBLING. IF WATER CAN BE SQUEEZED OUT OF THE BALL, IT IS TOO WET FOR PROPER COMPACTION.
- 3) EMBANKMENT AND KEY WAY MATERIAL AS WELL AS BACKFILL MATERIAL AROUND ENTIRE OUTFALL PIPE THROUGH BERM AND ANTI SEEP COLLARS SHALL BE PLACED IN 8" LIFTS AND COMPACTED TO 95% MAX. DRY DENSITY PER (ASTM D-1557).
- 4) AS-BUILT BASIN FOR TWP. APPROVAL, AFTER PLACING TOPSOIL IN BASIN AREA.

UPPER DUBLIN TOWNSHIP STANDARD DETAIL

BASIN



DATE

10-2013

NOT TO SCALE

DR330

*SPILLWAY TO BE LINED WITH RIPRAP, PAVERS, TRM OR SOD (AS SHOWN ON DESIGN PLANS)

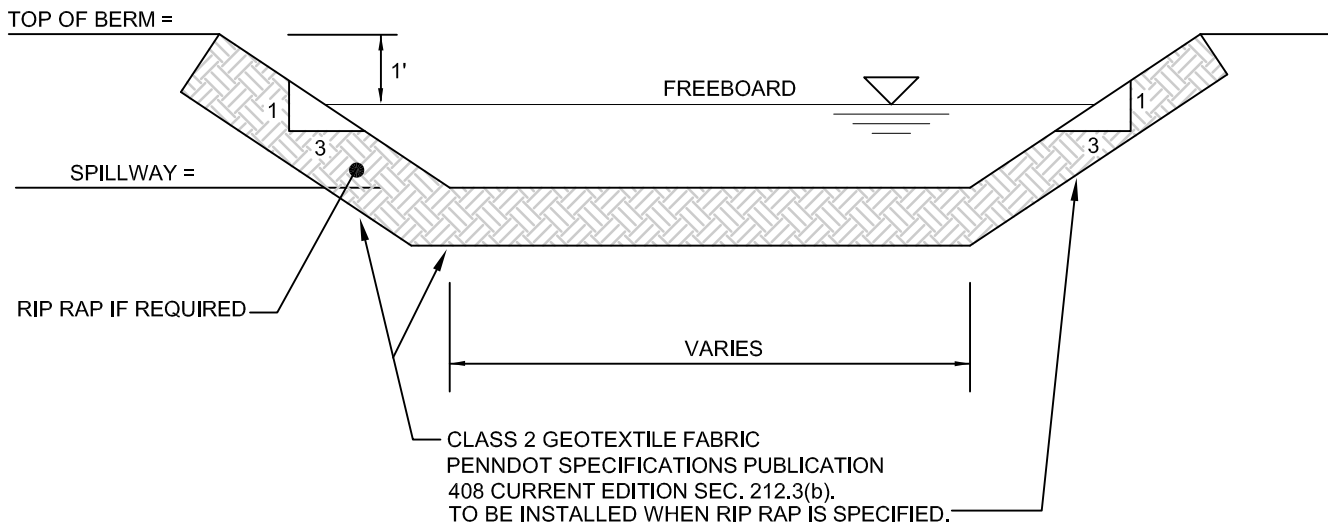
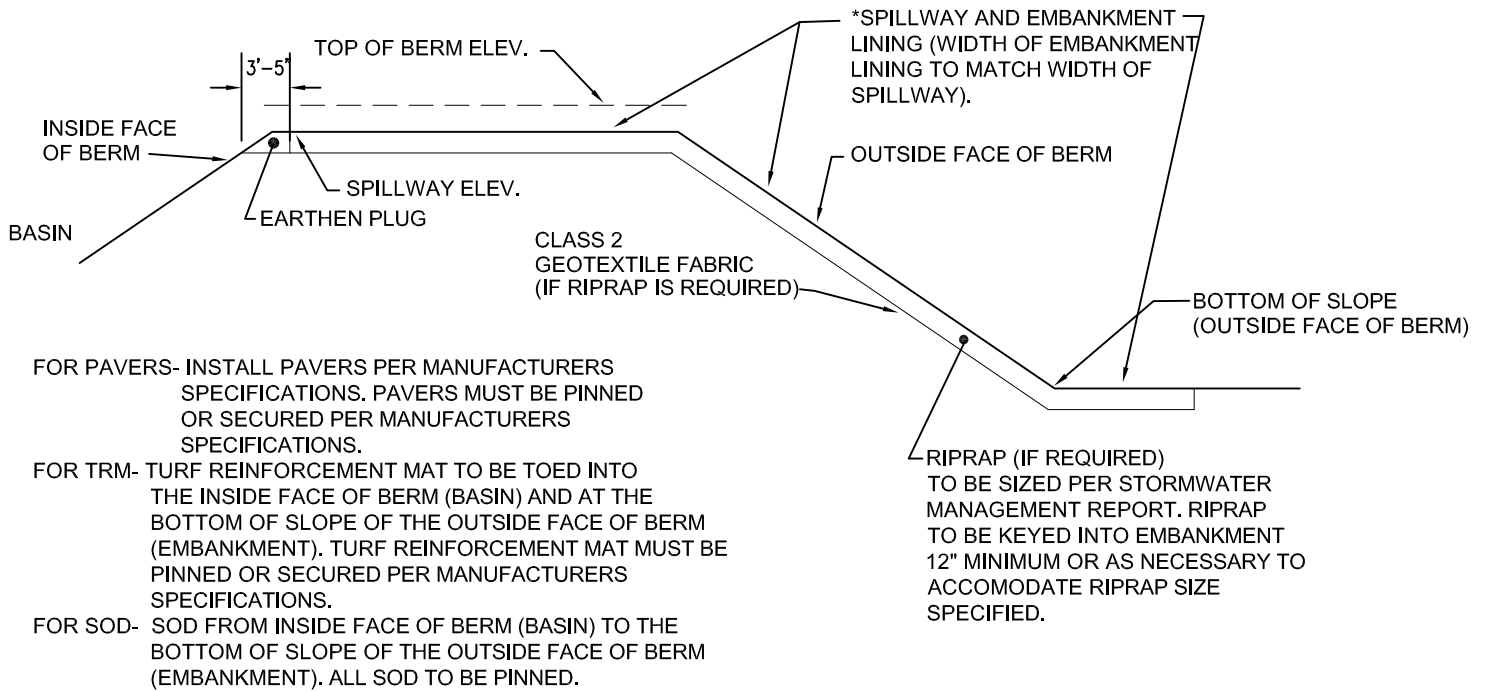

NOTES:

1. SPILLWAYS IN FILL TO BE LINED WITH CLASS 2 GEOTEXTILE FABRIC AND ARMORED WITH RIPRAP OR PAVERS. (RIPRAP TO BE SIZED PER STORMWATER MANAGEMENT REPORT) OR SPILLWAY AND EMBANKMENT TO BE LINED WITH NAG C-350 PERMANENT TURF REINFORCEMENT MAT OR APPROVED EQUAL.
2. SPILLWAYS IN CUT TO BE SOD LINED AND PINNED FROM INSIDE TOP OF BERM TO THE BOTTOM OF SLOPE (OUTSIDE OF BERM) OR SPILLWAY AND EMBANKMENT TO BE LINED WITH NAG C-350 PERMANENT TURF REINFORCEMENT MAT OR APPROVED EQUAL.

**UPPER DUBLIN TOWNSHIP STANDARD DETAIL
BASIN SPILLWAYS**



DATE

10-2013

NOT TO SCALE

DR331

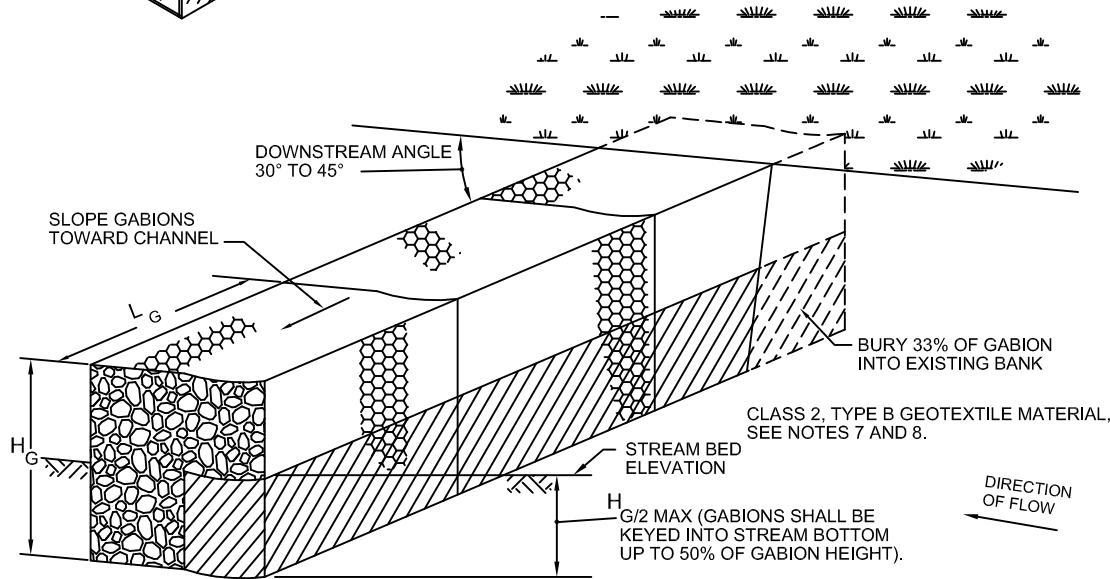
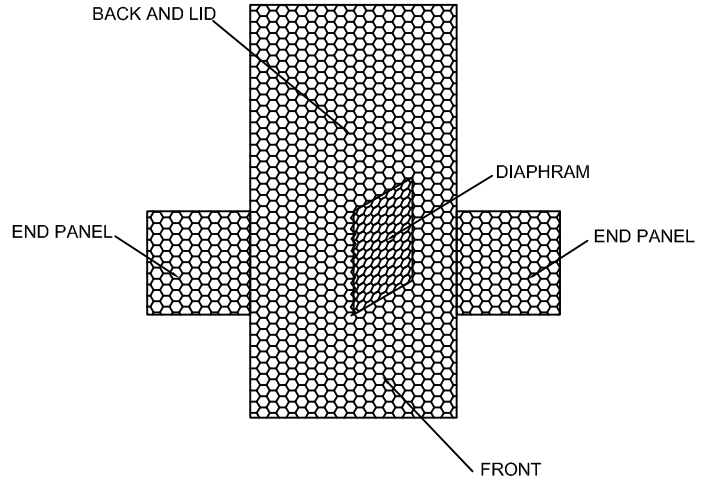
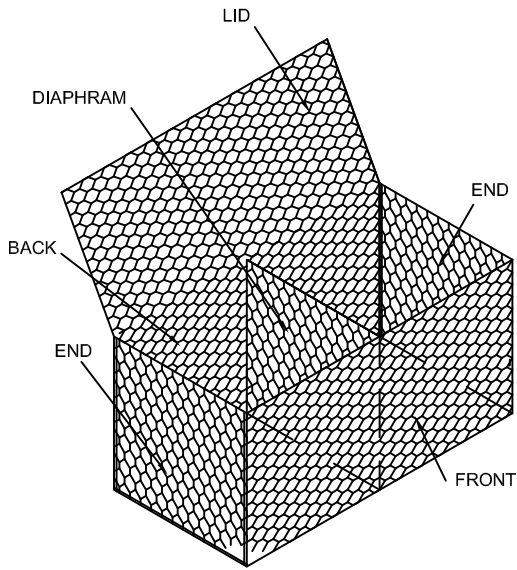

NOTES:

1. PROVIDE MATERIALS AND CONSTRUCTION MEETING THE REQUIREMENTS OF PUBLICATION 408, CURRENT EDITION, SECTION 626.
2. TYPE 'A' GABIONS SHALL CONSIST OF WIRE-MESH BASKETS FILLED BY HAND PLACEMENT OF COURSE AGGREGATE, AT LEAST ALONG THE EXPOSED FACES, FOR A UNIFORM APPEARANCE.
3. SPECIFY TYPE 'B' GABIONS OF WIRE-MESH BASKETS FILLED BY HAND PLACEMENT OR SMALL POWER EQUIPMENT PLACEMENT OF COURSE AGGREGATE.
4. MAKE CORROSION RESISTANT TYPE 'A' AND TYPE 'B' GABIONS THE SAME AS TYPE 'A' AND TYPE 'B' GABIONS EXCEPT SHEATH THE WIRE-MESH IN POLYVINYL CHLORIDE PLASTIC.
5. THE APRON OR TOE WALL IS REQUIRED WHERE THE SLOPE WALL IS INSTALLED ADJACENT TO WATER. MAKE THE APRON APPROXIMATELY TWO TIMES AS WIDE AS THE ANTICIPATED DEPTH OF SCOUR AND THE TOE WALL HEIGHT AT LEAST EQUAL TO THE ANTICIPATED DEPTH OF SCOUR.
6. WHEN GABIONS ARE PLACED ON A :1.5 (1.5:1) SIDE SLOPE OR STEEPER, DRIVE HARDWOOD STAKES THROUGH THE GABIONS, ALONG THE TOP EDGE, TO ANCHOR THE INSTALLATION. EMBED STAKES 18" MIN. BELOW GABION BOTTOM.
7. PROVIDE GEOTEXTILE MATERIAL MEETING THE REQUIREMENTS OF PUBLICATION 408, SECTION 212 AND SECTION 735, CURRENT EDITION.
8. INSTALL GEOTEXTILE MATERIAL ALONG ALL INTERFACE AREAS WITH GROUND CONTACT.
9. ALL DIMENSIONS ARE IN U.S. CUSTOMARY UNITS.

MATTRESS TYPE		
W _G	L _G	H _G
6'-0"	9'-0"	0'-9"
6'-0"	12'-0"	0'-9"

MATTRESS TYPE		
W _G	L _G	H _G
3'-0"	6'-0"	1'-0"
3'-0"	12'-0"	1'-0"
3'-0"	9'-0"	1'-6"
3'-0"	6'-0"	3'-0"
3'-0"	9'-0"	3'-0"
3'-0"	12'-0"	3'-0"

UPPER DUBLIN TOWNSHIP STANDARD DETAIL
GABIONS (CORROSION RESISTANT)



DATE 10-2013

NOT TO SCALE

DR332

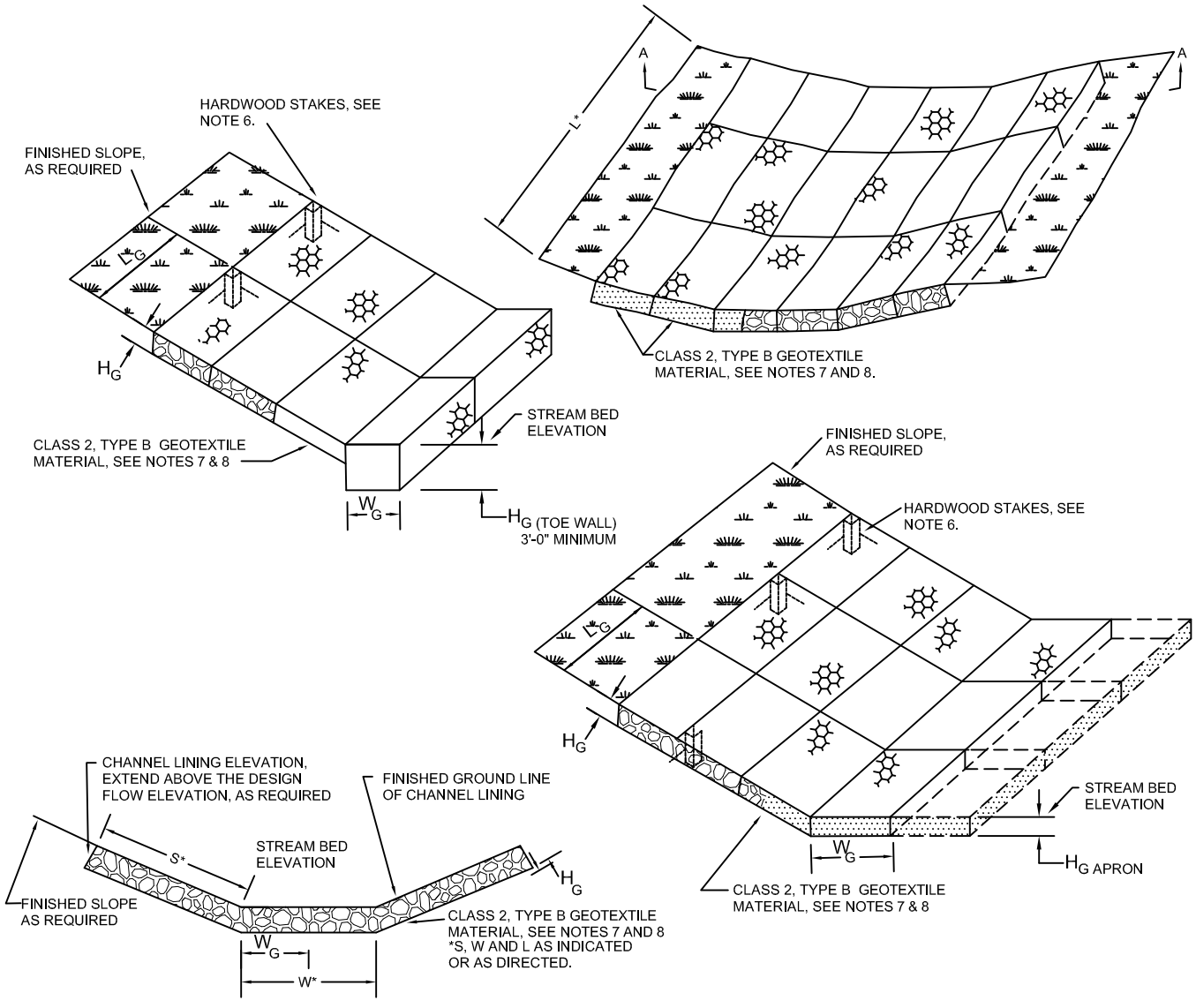

NOTES:

1. PROVIDE MATERIALS AND CONSTRUCTION MEETING THE REQUIREMENTS OF PUBLICATION 408, CURRENT EDITION, SECTION 626.
2. TYPE 'A' GABIONS SHALL CONSIST OF WIRE-MESH BASKETS FILLED BY HAND PLACEMENT OF COURSE AGGREGATE, AT LEAST ALONG THE EXPOSED FACES, FOR A UNIFORM APPEARANCE.
3. SPECIFY TYPE 'B' GABIONS OF WIRE-MESH BASKETS FILLED BY HAND PLACEMENT OR SMALL POWER EQUIPMENT PLACEMENT OF COURSE AGGREGATE.
4. MAKE CORROSION RESISTANT TYPE 'A' AND TYPE 'B' GABIONS THE SAME AS TYPE 'A' AND TYPE 'B' GABIONS EXCEPT SHEATH THE WIRE-MESH IN POLYVINYL CHLORIDE PLASTIC.
5. THE APRON OR TOE WALL IS REQUIRED WHERE THE SLOPE WALL IS INSTALLED ADJACENT TO WATER. MAKE THE APRON APPROXIMATELY TWO TIMES AS WIDE AS THE ANTICIPATED DEPTH OF SCOUR AND THE TOE WALL HEIGHT AT LEAST EQUAL TO THE ANTICIPATED DEPTH OF SCOUR.
6. WHEN GABIONS ARE PLACED ON A 1:1.5 (1.5:1) SIDE SLOPE OR STEEPER, DRIVE HARDWOOD STAKES THROUGH THE GABIONS, ALONG THE TOP EDGE, TO ANCHOR THE INSTALLATION. EMBED STAKES 450 (18") MIN. BELOW GABION BOTTOM.
7. PROVIDE GEOTEXTILE MATERIAL MEETING THE REQUIREMENTS OF PUBLICATION 408 /2000, SECTION 212 AND SECTION 735.
8. INSTALL GEOTEXTILE MATERIAL ALONG ALL INTERFACE AREAS WITH GROUND CONTACT.
9. ALL DIMENSIONS ARE IN U.S. CUSTOMARY UNITS.

MATTRESS TYPE		
W_G	L_G	H_G
6'-0"	9'-0"	0'-9"
6'-0"	12'-0"	0'-9"

MATTRESS TYPE		
W_G	L_G	H_G
3'-0"	6'-0"	1'-0"
3'-0"	12'-0"	1'-0"
3'-0"	9'-0"	1'-6"
3'-0"	6'-0"	3'-0"
3'-0"	9'-0"	3'-0"
3'-0"	12'-0"	3'-0"

**UPPER DUBLIN TOWNSHIP STANDARD DETAIL
GABIONS (CORROSION RESISTANT)**



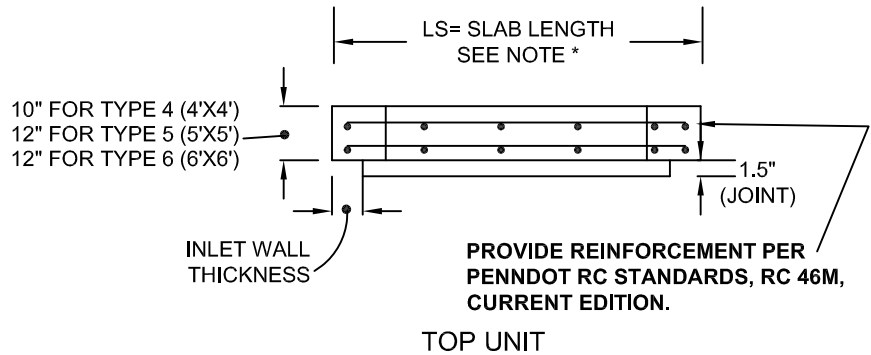
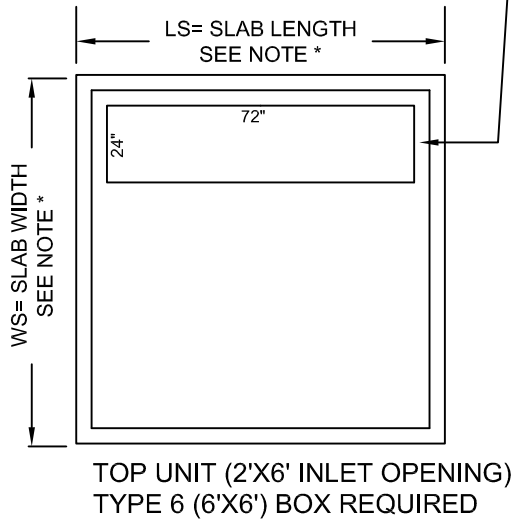
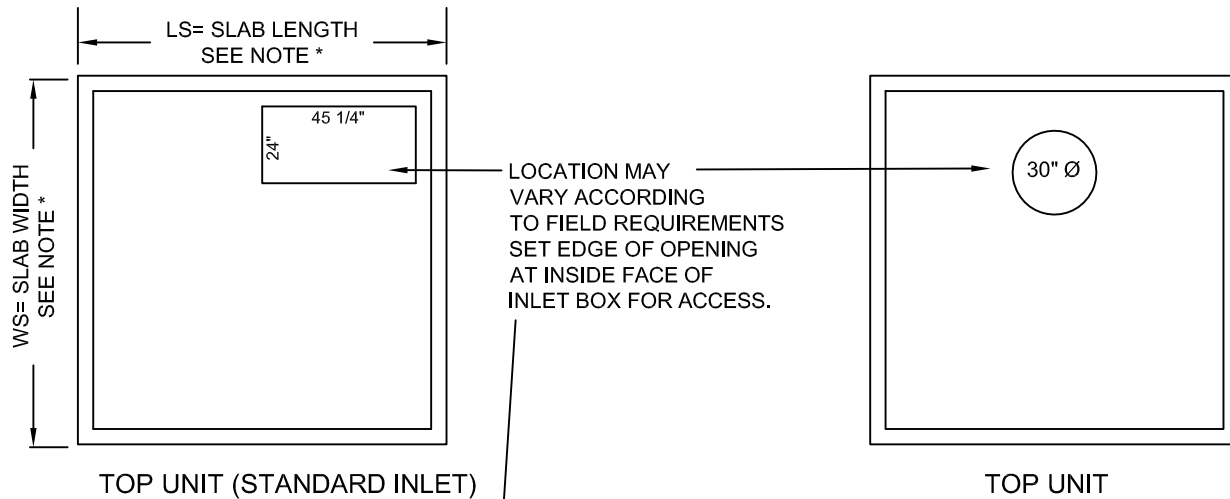

NOTE: *
OUT TO OUT DIMENSIONS OF TOP SLABS TO MATCH THE SIZE OF THE INLET BOX.

CONSTRUCTION REQUIREMENTS:

1. CONSTRUCT IN ACCORDANCE WITH PENNDOT 408 CURRENT EDITION SECTION 714, PENNDOT RC STANDARDS, RC 46M, CURRENT EDITION AND AS MODIFIED HEREIN.
2. ALL CONCRETE SHALL BE CLASS AA MODIFIED DESIGN COMPRESSIVE STRENGTH (4000 PSI).
3. PROVIDE STEEL REINFORCEMENT IN ACCORDANCE WITH PENNDOT 408 CURRENT EDITION SECTION 709.
4. ALL REINFORCEMENT SHALL HAVE A MINIMUM CLEARANCE OF 1.5" FROM FACE OF CONCRETE.
5. ALL SLABS ARE REQUIRED TO BE DESIGNED TO MEET HS25 LIVE LOADING.
6. COVER ADJUSTMENT SLABS REQUIRE A CONSTRUCTION JOINT BETWEEN INLET BOX AND SLAB.
7. COVER ADJUSTMENT SLABS AS MANUFACTURED BY RAHNS CONSTRUCTION MATERIALS CO. OR APPROVED EQUAL.

UPPER DUBLIN TOWNSHIP STANDARD DETAIL
TOP SLAB
STANDARD AND 6' INLET AND MANHOLE OPENING



DATE

10-2013

NOT TO SCALE

DR334

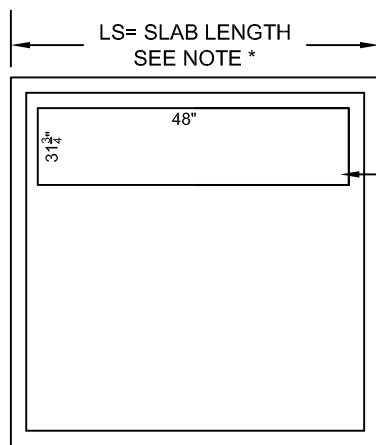

TOP UNIT (FOR 4' SPECIAL)

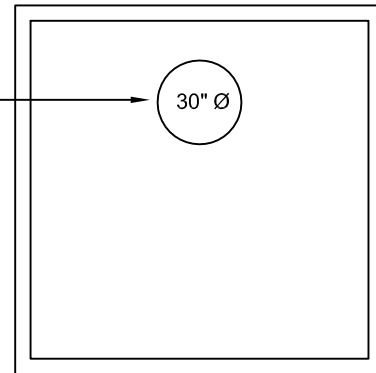

TOP UNIT
MANHOLE OPENING

LOCATION MAY VARY ACCORDING TO FIELD REQUIREMENTS SET EDGE OF OPENING AT INSIDE FACE OF INLET BOX FOR ACCESS.

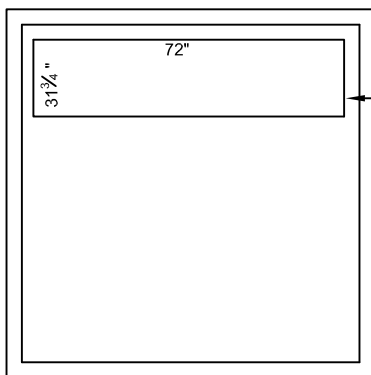

TOP UNIT (FOR 6' SPECIAL)
TYPE 6 (6'X6') BOX REQUIRED

10" FOR TYPE 4 (4'X4')
12" FOR TYPE 5 (5'X5')
12" FOR TYPE 6 (6'X6')

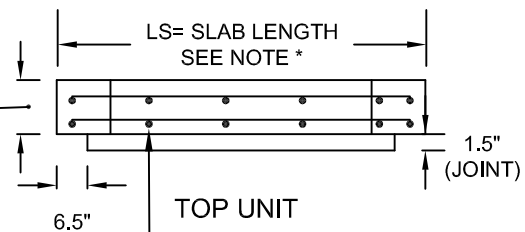

TOP UNIT

PROVIDE REINFORCEMENT PER PENNDOT RC STANDARDS, RC 46M, CURRENT EDITION.

NOTE: *
OUT TO OUT DIMENSIONS OF
TOP SLABS TO MATCH THE
SIZE OF THE INLET BOX.

1. CONSTRUCT IN ACCORDANCE WITH PENNDOT 408 CURRENT EDITION SECTION 714, PENNDOT RC STANDARDS, RC 46M, CURRENT EDITION AND AS MODIFIED HEREIN.
2. ALL CONCRETE SHALL BE CLASS AA MODIFIED DESIGN COMPRESSIVE STRENGTH (4000 PSI).
3. PROVIDE STEEL REINFORCEMENT IN ACCORDANCE WITH PENNDOT 408 CURRENT EDITION SECTION 709.
4. ALL REINFORCEMENT SHALL HAVE A MINIMUM CLEARANCE OF 1.5" FROM FACE OF CONCRETE.
5. ALL SLABS ARE REQUIRED TO BE DESIGNED TO MEET HS25 LIVE LOADING.
6. COVER ADJUSTMENT SLABS REQUIRE A CONSTRUCTION JOINT BETWEEN INLET BOX AND SLAB.
7. COVER ADJUSTMENT SLABS AS MANUFACTURED BY RAHNS CONSTRUCTION MATERIALS CO. OR APPROVED EQUAL.

UPPER DUBLIN TOWNSHIP STANDARD DETAIL
TOP SLAB
FOR 4' AND 6' SPECIAL INLET OPENING AND MANHOLE OPENING



DATE

10-2013

NOT TO SCALE

DR335

REINFORCEMENT BARS OR WELDED WIRE FABRIC:
SEE NOTES 4 & 5

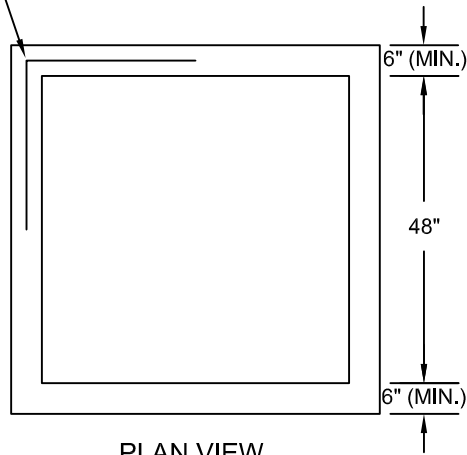

PLAN VIEW

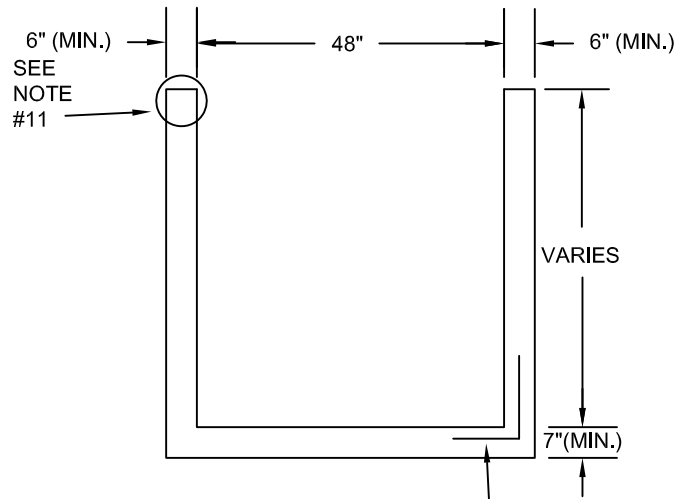

SIDE VIEW

REINFORCEMENT BARS
OR WELDED WIRE FABRIC:
SEE NOTES 4 & 5

NOTES

1. CONSTRUCTION REQUIREMENTS

- A. CONSTRUCT IN ACCORDANCE WITH: PENNDOT 408, CURRENT EDITION, SECTIONS 605, 714, PENNDOT RC STANDARDS, RC 46M, CURRENT EDITION AND AS MODIFIED HEREIN.
- B. MINIMUM CONCRETE COMPRESSIVE STRENGTH:
 - CAST-IN-PLACE CLASS AA MODIFIED DESIGN COMPRESSIVE STRENGTH (4000 PSI).
 - PRECAST CLASS AA MODIFIED DESIGN COMPRESSIVE STRENGTH (4000 PSI).
- C. PROVIDE STEEL REINFORCEMENT IN ACCORDANCE WITH SEC. 709. PROVIDE MINIMUM YIELD STRENGTH OF 60,000 P.S.I.
 - D. CLEAR COVER FOR STEEL:
 - WALLS: CAST-IN-PLACE 2"
 - PRECAST 1 1/2"
 - FOOTINGS: CAST-IN-PLACE 2 1/2" (TOP BARS) 3" (BOTTOM BARS) 2" (SIDE COVER)
 - PRECAST 2" (TOP BARS) 1 1/2" (BOTTOM BARS) 1 1/2" (SIDE COVER)
 - SLABS: CAST-IN-PLACE 2" (TOP AND BOTTOM BARS)
 - E. DESIGN FOR HS 25 LIVE LOADING.
- 2. THE SELECTION OF COMPONENTS TO ACHIEVE A SPECIFIED INLET ASSEMBLY IS THE CONTRACTORS RESPONSIBILITY
- 3. FOR BASE SECTION REINFORCEMENT: PROVIDE REINFORCEMENT PER PENNDOT RC STANDARDS, RC 46M, CURRENT EDITION.
- 4. FOR RISER SECTION REINFORCEMENT: PROVIDE REINFORCEMENT PER PENNDOT RC STANDARDS, RC 46M, CURRENT EDITION.
- 5. FRAMES AND GRATES SHALL BE PADOT TYPE C STRUCTURAL STEEL.

- 6. PROVIDE WEEP HOLES FOR DRAINAGE AT THE DIRECTION OF THE TOWNSHIP ENGINEER OR HIS/HER REPRESENTATIVE IN THE FIELD.
- 7. GRATES SHALL BE PADOT "BICYCLE SAFE".
- 8. DOWEL PIN ALL HOODS INTO CURB W/(2) #8X1'-0" DOWEL BARS.
- 9. CONSTRUCT INLETS THAT EXCEED 5 FEET IN HEIGHT WITH STEPS SIMILAR TO MANHOLES.
- 10. ONE PRECAST CONCRETE ADJUSTMENT RING AND NON SHRINK GROUT IS REQUIRED FOR UP TO 10" OF ADJUSTMENT. A PRECAST CONCRETE RISER OR RISERS IS REQUIRED FOR ADJUSTMENT ABOVE 10". BRICK OR BRICK AND MORTAR ARE NOT ALLOWED FOR GRADE ADJUSTMENTS.
- 11. ALL INLETS REQUIRE CONSTRUCTION JOINTS OR KEYS FOR RISER SECTIONS AND PRECAST COVER ADJUSTMENT SLABS.
- 12. MASTIC REQUIRED AT ALL CONSTRUCTION JOINTS OR KEYS. UNDER STEEL FRAMES AND AS REQUIRED BY THE TOWNSHIP ENGINEER OR HIS/HER REPRESENTATIVE IN THE FIELD.
- 13. PIPE OPENINGS ARE PERMITTED TO BE IN EACH WALL WHEN CORNER PENETRATIONS ARE NOT REQUIRED.
- 14. IF CORNER PENETRATION IS REQUIRED, PIPE OPENINGS ARE PERMITTED IN ONE (1) CORNER AND IN THE TWO (2) OTHER WALLS NOT AFFECTED BY THE CORNER PENETRATION.
- 15. FORM BOTTOM OF INLET USING CLASS AA CEMENT CONCRETE. TO CHANNEL THE FLOW TOWARD THE OUTLET PIPE. REFER TO UD TWP DETAIL DR349.
- 16. 4'X4' INLET BOXES AS MANUFACTURED BY RAHNS CONSTRUCTION MATERIALS CO. OR APPROVED EQUAL.
- 17. FORM BOTTOM OF INLET USING CLASS AA CEMENT CONCRETE. TO CHANNEL THE FLOW TOWARD THE OUTLET PIPE. REFER TO UD TWP DETAIL DR349.
- 18. PIPE OPENINGS ARE PERMITTED TO BE IN EACH WALL WHEN CORNER PENETRATIONS ARE NOT REQUIRED.
- 19. ALL PENETRATIONS/OPENINGS AROUND THE PIPES(S) MUST BE FORMED AND FILLED WITH CLASS AA (3750 PSI MINIMUM COMPRESSIVE STRENGTH) CEMENT CONCRETE. REFER TO UPPER DUBLIN TOWNSHIP DETAIL DR348.

UPPER DUBLIN TOWNSHIP STANDARD DETAIL

TYPE 4 (4'X4') INLET BOX



DATE

10-2013

NOT TO SCALE

DR336

REINFORCEMENT BARS OR WELDED WIRE FABRIC:
SEE NOTES 4 & 5

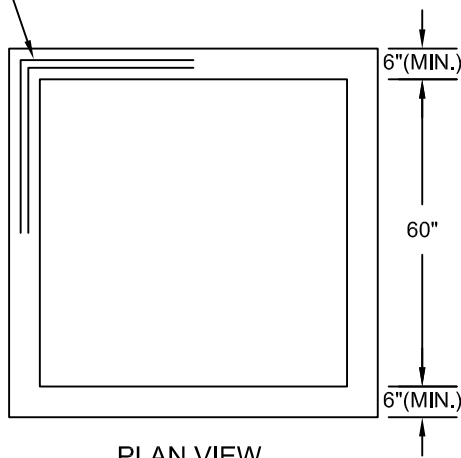

PLAN VIEW

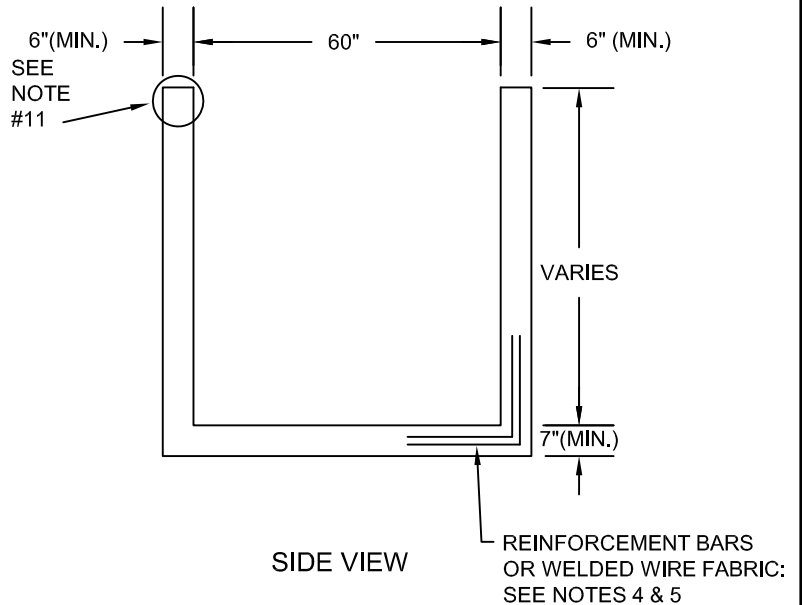

SIDE VIEW

REINFORCEMENT BARS
OR WELDED WIRE FABRIC:
SEE NOTES 4 & 5

NOTES

1. CONSTRUCTION REQUIREMENTS
 - A. CONSTRUCT IN ACCORDANCE WITH: PENNDOT 408, CURRENT EDITION, SECTIONS 605, 714, PENNDOT RC STANDARDS, RC 46M, CURRENT EDITION AND AS MODIFIED HEREIN.
 - B. MINIMUM CONCRETE COMPRESSIVE STRENGTH:

CAST-IN-PLACE	CLASS AA MODIFIED DESIGN	COMPRESSIVE STRENGTH (4000 PSI).
PRECAST	CLASS AA MODIFIED DESIGN	COMPRESSIVE STRENGTH (4000 PSI).
 - C. PROVIDE STEEL REINFORCEMENT IN ACCORDANCE WITH SEC. 709. PROVIDE MINIMUM YIELD STRENGTH OF 60,000 P.S.I.
 - D. CLEAR COVER FOR STEEL:

WALLS:	CAST-IN-PLACE	2"
	PRECAST	1 1/2"
FOOTINGS:	CAST-IN-PLACE	2 1/2" (TOP BARS)
		3" (BOTTOM BARS)
		2" (SIDE COVER)
	PRECAST	2" (TOP BARS)
		1 1/2" (BOTTOM BARS)
		1 1/2" (SIDE COVER)
SLABS:	CAST-IN-PLACE	2" (TOP AND BOTTOM BARS)
 - E. DESIGN FOR HS 25 LIVE LOADING.
2. THE SELECTION OF COMPONENTS TO ACHIEVE A SPECIFIED INLET ASSEMBLY IS THE CONTRACTORS RESPONSIBILITY
3. FOR BASE SECTION REINFORCEMENT: PROVIDE REINFORCEMENT PER PENNDOT RC STANDARDS, RC 46M, CURRENT EDITION.
4. FOR RISER SECTION REINFORCEMENT: PROVIDE REINFORCEMENT PER PENNDOT RC STANDARDS, RC 46M, CURRENT EDITION.
5. FRAMES AND GRATES SHALL BE PADOT TYPE C STRUCTURAL STEEL.
6. PROVIDE WEEP HOLES FOR DRAINAGE AT THE DIRECTION OF THE TOWNSHIP ENGINEER OR HIS/HER REPRESENTATIVE IN THE FIELD.
7. GRATES SHALL BE PADOT "BICYCLE SAFE".
8. DOWEL PIN ALL HOODS INTO CURB W/(2) #8X1'-0" DOWEL BARS.
9. CONSTRUCT INLETS THAT EXCEED 5 FEET IN HEIGHT WITH STEPS SIMILAR TO MANHOLES.
10. ONE PRECAST CONCRETE ADJUSTMENT RING AND NON SHRINK GROUT IS REQUIRED FOR UP TO 10" OF ADJUSTMENT. A PRECAST CONCRETE RISER OR RISERS IS REQUIRED FOR ADJUSTMENT ABOVE 10". BRICK OR BRICK AND MORTAR ARE NOT ALLOWED FOR GRADE ADJUSTMENTS.
11. ALL INLETS REQUIRE CONSTRUCTION JOINTS OR KEYS FOR RISER SECTIONS AND PRECAST COVER ADJUSTMENT SLABS.
12. MASTIC REQUIRED AT ALL CONSTRUCTION JOINTS OR KEYS. UNDER STEEL FRAMES AND AS REQUIRED BY THE TOWNSHIP ENGINEER OR HIS/HER REPRESENTATIVE IN THE FIELD.
13. PIPE OPENINGS ARE PERMITTED TO BE IN EACH WALL WHEN CORNER PENETRATIONS ARE NOT REQUIRED.
14. IF CORNER PENETRATION IS REQUIRED, PIPE OPENINGS ARE PERMITTED IN ONE (1) CORNER AND IN THE TWO (2) OTHER WALLS NOT AFFECTED BY THE CORNER PENETRATION.
15. FORM BOTTOM OF INLET USING CLASS AA CEMENT CONCRETE. TO CHANNEL THE FLOW TOWARD THE OUTLET PIPE. REFER TO UD TWP DETAIL DR349.
16. 5'X5' INLET BOXES AS MANUFACTURED BY RAHNS CONSTRUCTION MATERIALS CO. OR APPROVED EQUAL.
17. FORM BOTTOM OF INLET USING CLASS AA CEMENT CONCRETE. TO CHANNEL THE FLOW TOWARD THE OUTLET PIPE. REFER TO UD TWP DETAIL DR349.
18. PIPE OPENINGS ARE PERMITTED TO BE IN EACH WALL WHEN CORNER PENETRATIONS ARE NOT REQUIRED.
19. ALL PENETRATIONS/OPENINGS AROUND THE PIPES(S) MUST BE FORMED AND FILLED WITH CLASS AA (3750 PSI MINIMUM COMPRESSIVE STRENGTH) CEMENT CONCRETE. REFER TO UPPER DUBLIN TOWNSHIP DETAIL DR348.

**UPPER DUBLIN TOWNSHIP STANDARD DETAIL
TYPE 5 (5'X5') INLET BOX**



DATE

10-2013

NOT TO SCALE

DR337

REINFORCEMENT BARS OR WELDED WIRE FABRIC:
SEE NOTES 4 & 5

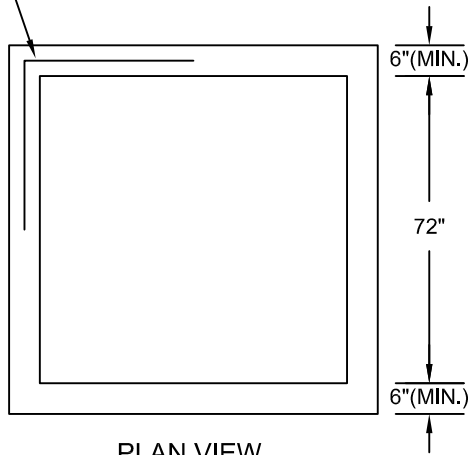

PLAN VIEW

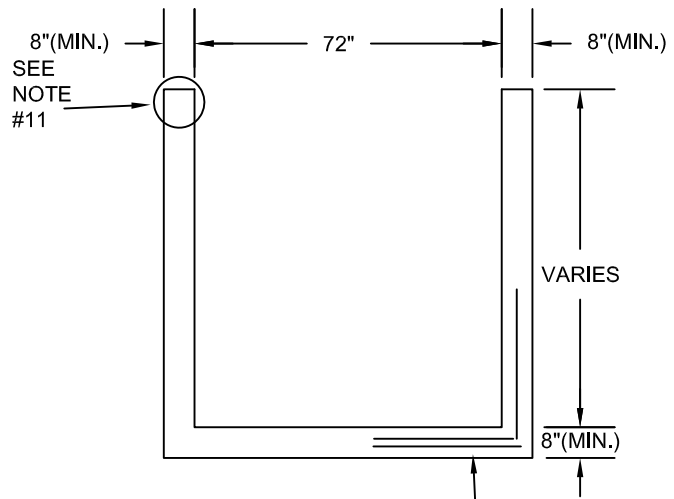

SIDE VIEW

REINFORCEMENT BARS
OR WELDED WIRE FABRIC:
SEE NOTES 4 & 5

NOTES

1. CONSTRUCTION REQUIREMENTS
 - A. CONSTRUCT IN ACCORDANCE WITH: PENNDOT 408, CURRENT EDITION, SECTIONS 605, 714, PENNDOT RC STANDARDS, RC 46M, CURRENT EDITION AND AS MODIFIED HEREIN.
 - B. MINIMUM CONCRETE COMPRESSIVE STRENGTH:

CAST-IN-PLACE	CLASS AA MODIFIED DESIGN	COMPRESSIVE STRENGTH (4000 PSI).
PRECAST	CLASS AA MODIFIED DESIGN	COMPRESSIVE STRENGTH (4000 PSI).
 - C. PROVIDE STEEL REINFORCEMENT IN ACCORDANCE WITH SEC. 709. PROVIDE MINIMUM YIELD STRENGTH OF 60,000 P.S.I.
 - D. CLEAR COVER FOR STEEL:

WALLS:	CAST-IN-PLACE	2"
	PRECAST	1 1/2"
FOOTINGS:	CAST-IN-PLACE	2 1/2" (TOP BARS)
		3" (BOTTOM BARS)
		2" (SIDE COVER)
	PRECAST	2" (TOP BARS)
		1 1/2" (BOTTOM BARS)
		1 1/2" (SIDE COVER)
SLABS:	CAST-IN-PLACE	2" (TOP AND BOTTOM BARS)
 - E. DESIGN FOR HS 25 LIVE LOADING.
2. THE SELECTION OF COMPONENTS TO ACHIEVE A SPECIFIED INLET ASSEMBLY IS THE CONTRACTORS RESPONSIBILITY
3. FOR BASE SECTION REINFORCEMENT: PROVIDE REINFORCEMENT PER PENNDOT RC STANDARDS, RC 46M, CURRENT EDITION.
4. FOR RISER SECTION REINFORCEMENT: PROVIDE REINFORCEMENT PER PENNDOT RC STANDARDS, RC 46M, CURRENT EDITION.
5. FRAMES AND GRATES SHALL BE PADOT TYPE C STRUCTURAL STEEL.
6. PROVIDE WEEP HOLES FOR DRAINAGE AT THE DIRECTION OF THE TOWNSHIP ENGINEER OR HIS/HER REPRESENTATIVE IN THE FIELD.
7. GRATES SHALL BE PADOT "BICYCLE SAFE".
8. DOWEL PIN ALL HOODS INTO CURB W/(2) #8X1'-0" DOWEL BARS.
9. CONSTRUCT INLETS THAT EXCEED 5 FEET IN HEIGHT WITH STEPS SIMILAR TO MANHOLES.
10. ONE PRECAST CONCRETE ADJUSTMENT RING AND NON SHRINK GROUT IS REQUIRED FOR UP TO 10" OF ADJUSTMENT. A PRECAST CONCRETE RISER OR RISERS IS REQUIRED FOR ADJUSTMENT ABOVE 10". BRICK OR MORTAR ARE NOT ALLOWED FOR GRADE ADJUSTMENTS.
11. ALL INLETS REQUIRE CONSTRUCTION JOINTS OR KEYS FOR RISER SECTIONS AND PRECAST COVER ADJUSTMENT SLABS.
12. MASTIC REQUIRED AT ALL CONSTRUCTION JOINTS OR KEYS. UNDER STEEL FRAMES AND AS REQUIRED BY THE TOWNSHIP ENGINEER OR HIS/HER REPRESENTATIVE IN THE FIELD.
13. PIPE OPENINGS ARE PERMITTED TO BE IN EACH WALL WHEN CORNER PENETRATIONS ARE NOT REQUIRED.
14. IF CORNER PENETRATION IS REQUIRED, PIPE OPENINGS ARE PERMITTED IN ONE (1) CORNER AND IN THE TWO (2) OTHER WALLS NOT AFFECTED BY THE CORNER PENETRATION.
15. FORM BOTTOM OF INLET USING CLASS AA CEMENT CONCRETE. TO CHANNEL THE FLOW TOWARD THE OUTLET PIPE. REFER TO UD TWP DETAIL DR349.
16. 6'X6' INLET BOXES AS MANUFACTURED BY RAHNS CONSTRUCTION MATERIALS CO. OR APPROVED EQUAL.
17. FORM BOTTOM OF INLET USING CLASS AA CEMENT CONCRETE. TO CHANNEL THE FLOW TOWARD THE OUTLET PIPE. REFER TO UD TWP DETAIL DR349.
18. PIPE OPENINGS ARE PERMITTED TO BE IN EACH WALL WHEN CORNER PENETRATIONS ARE NOT REQUIRED.
19. ALL PENETRATIONS/OPENINGS AROUND THE PIPES(S) MUST BE FORMED AND FILLED WITH CLASS AA (3750 PSI MINIMUM COMPRESSIVE STRENGTH) CEMENT CONCRETE. REFER TO UPPER DUBLIN TOWNSHIP DETAIL DR348.

**UPPER DUBLIN TOWNSHIP STANDARD DETAIL
TYPE 6 (6'X6') INLET BOX**



DATE

10-2013

NOT TO SCALE

DR338

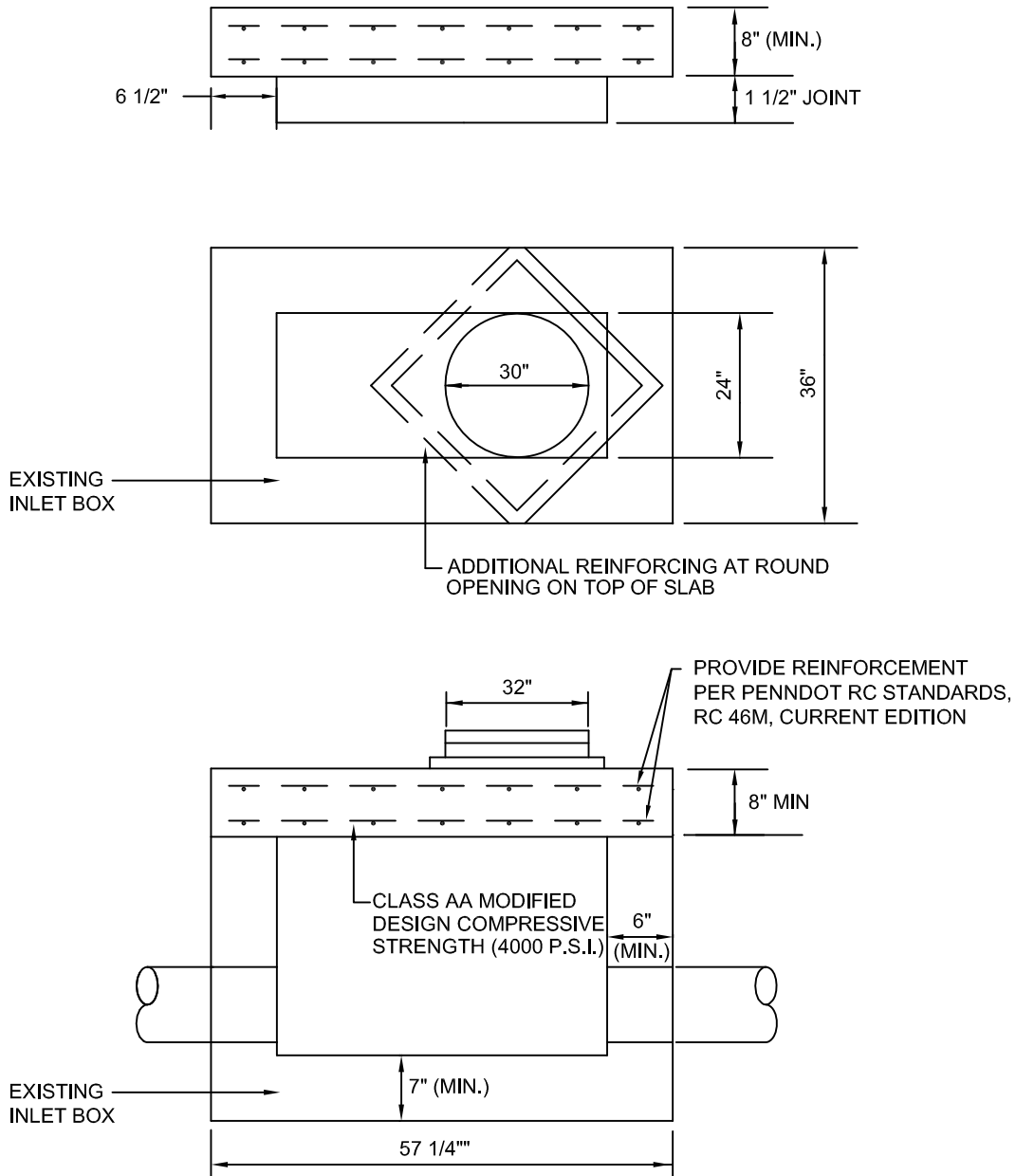

NOTES

1. CONSTRUCT IN ACCORDANCE WITH THE REQUIREMENTS OF PENNDOT PUB. 408 SEC. 714, PENNDOT RC STANDARDS, RC46M, CURRENT EDITION.
2. ALL CONCRETE SHALL BE CLASS AA MODIFIED DESIGN COMPRESSIVE STRENGTH (4000 PSI).
3. PROVIDE STEEL REINFORCEMENT IN ACCORDANCE WITH PENNDOT PUB. 408. SEC. 709.
4. ALL REINFORCEMENT SHALL HAVE A MINIMUM CLEARANCE OF 1.5" FROM FACE OF CONCRETE.
5. ALL SLABS ARE REQUIRED TO BE DESIGNED TO MEET HS 25 LIVE LOADING.
6. FOR A STANDARD BOX, PROVIDE A 24" OPENING IN TOP SLAB.
7. DESIGN MANHOLE FRAME, COVER AND GRADE ADJUSTMENT RINGS FOR (HS 25) LIVE LOAD.
8. PROVIDE MANHOLE FRAMES AND COVERS SUPPLIED BY MANUFACTURER AS LISTED IN BULLETIN 15.
9. REFER TO UPPER DUBLIN TOWNSHIP DETAIL DR311 FOR FRAME AND COVER.
10. FRAME AND/OR PRECAST CONCRETE GRADE RING TO BE ATTACHED RIGIDLY (BOLTED) TO TOP SLAB.

**UPPER DUBLIN TOWNSHIP STANDARD DETAIL
CONVERTING STANDARD INLET BOX
TO STORM MANHOLE**



DATE

10-2013

NOT TO SCALE

DR339

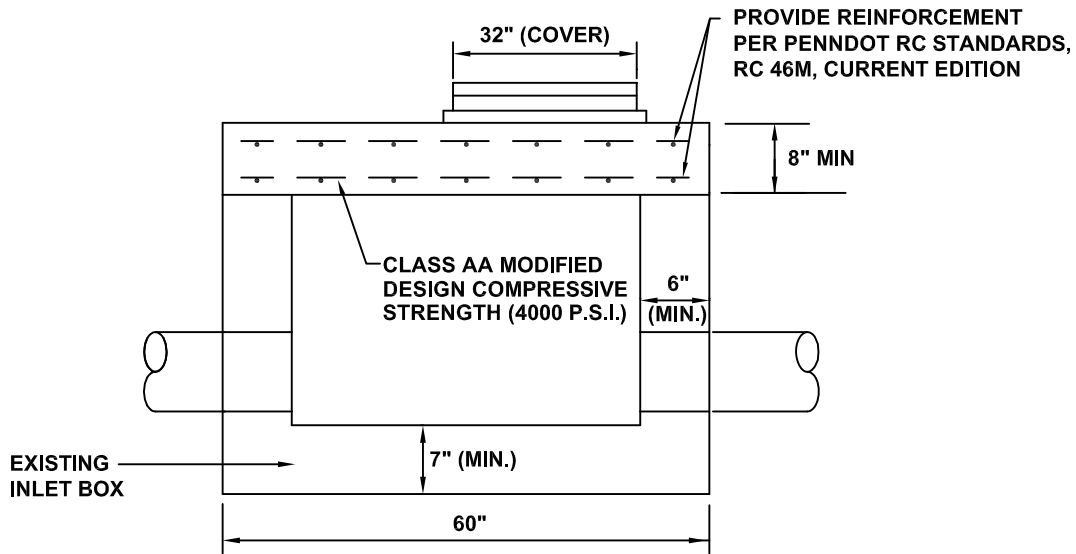
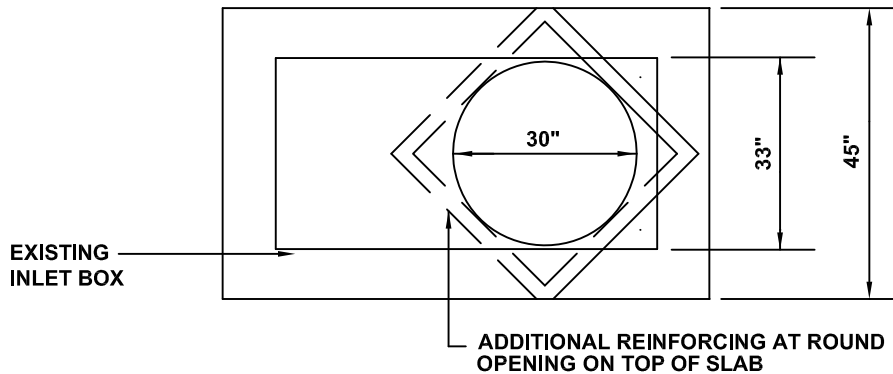
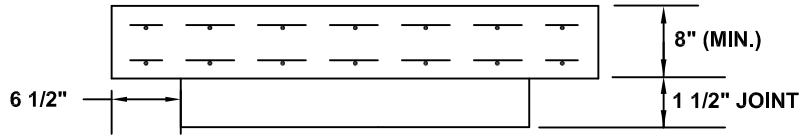

NOTES

1. CONSTRUCT IN ACCORDANCE WITH THE REQUIREMENTS OF PENNDOT PUB. 408 SEC. 714, PENNDOT RC STANDARDS, RC 46M, CURRENT EDITION.
2. ALL CONCRETE SHALL BE CLASS AA MODIFIED DESIGN COMPRESSIVE STRENGTH (4000 PSI).
3. PROVIDE STEEL REINFORCEMENT IN ACCORDANCE WITH PENNDOT PUB. 408. SEC. 709.
4. ALL REINFORCEMENT SHALL HAVE A MINIMUM CLEARANCE OF 1.5" FROM FACE OF CONCRETE.
5. ALL SLABS ARE REQUIRED TO BE DESIGNED TO MEET HS 25 LIVE LOADING.
6. REFER TO UPPER DUBLIN TOWNSHIP DETAIL DR311 FOR FRAME AND COVER.
7. FRAME AND/OR PRECAST CONCRETE RINGS TO BE ATTACHED RIGIDLY (BOLTED) TO TOP SLAB.

UPPER DUBLIN TOWNSHIP STANDARD DETAIL
 CONVERTING 4' SPECIAL INLET BOX
 TO STORM MANHOLE



DATE

10-2013

NOT TO SCALE

DR340

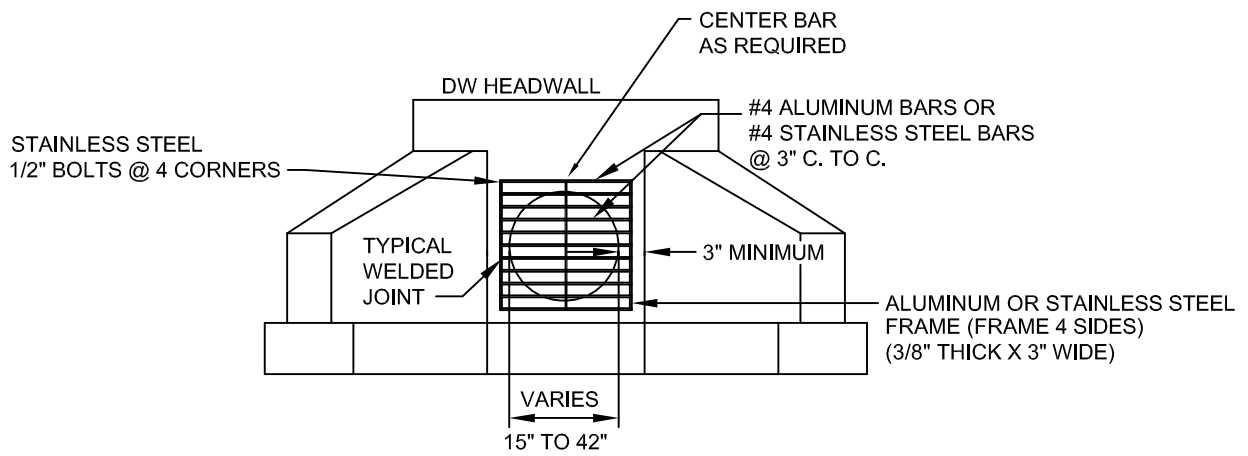

UPPER DUBLIN TOWNSHIP STANDARD DETAIL
SAFETY GRATE DETAIL



DATE

10-2013

NOT TO SCALE

DR341

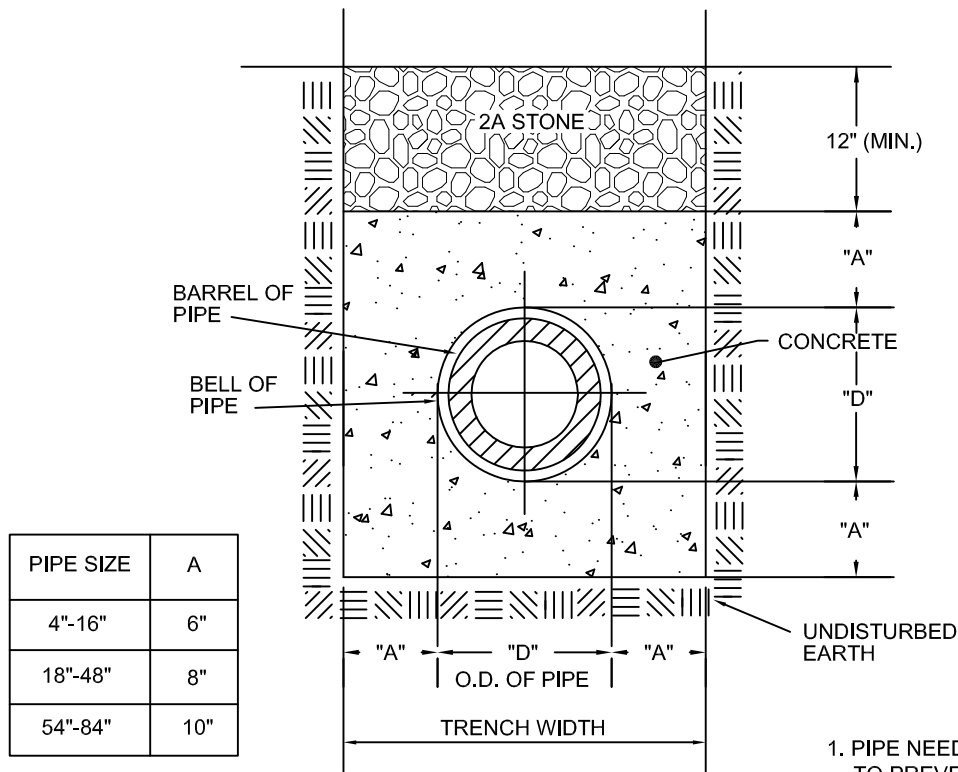

1. PIPE NEEDS TO BE SECURED TO PREVENT FLOATATION. PRIOR TO CONCRETE POUR.
2. 3750 PSI HIGH EARLY STRENGTH CONCRETE.

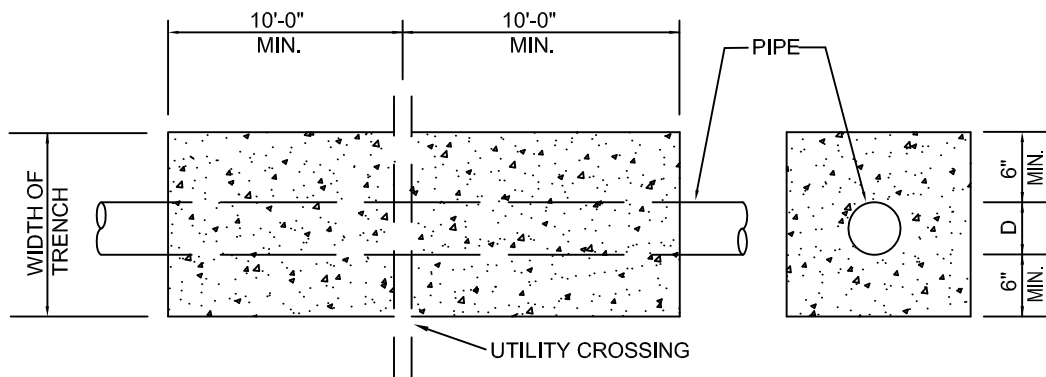

UPPER DUBLIN TOWNSHIP STANDARD DETAIL
TYPICAL CONCRETE ENCASEMENT DETAIL



DATE

10-2013

NOT TO SCALE

DR342

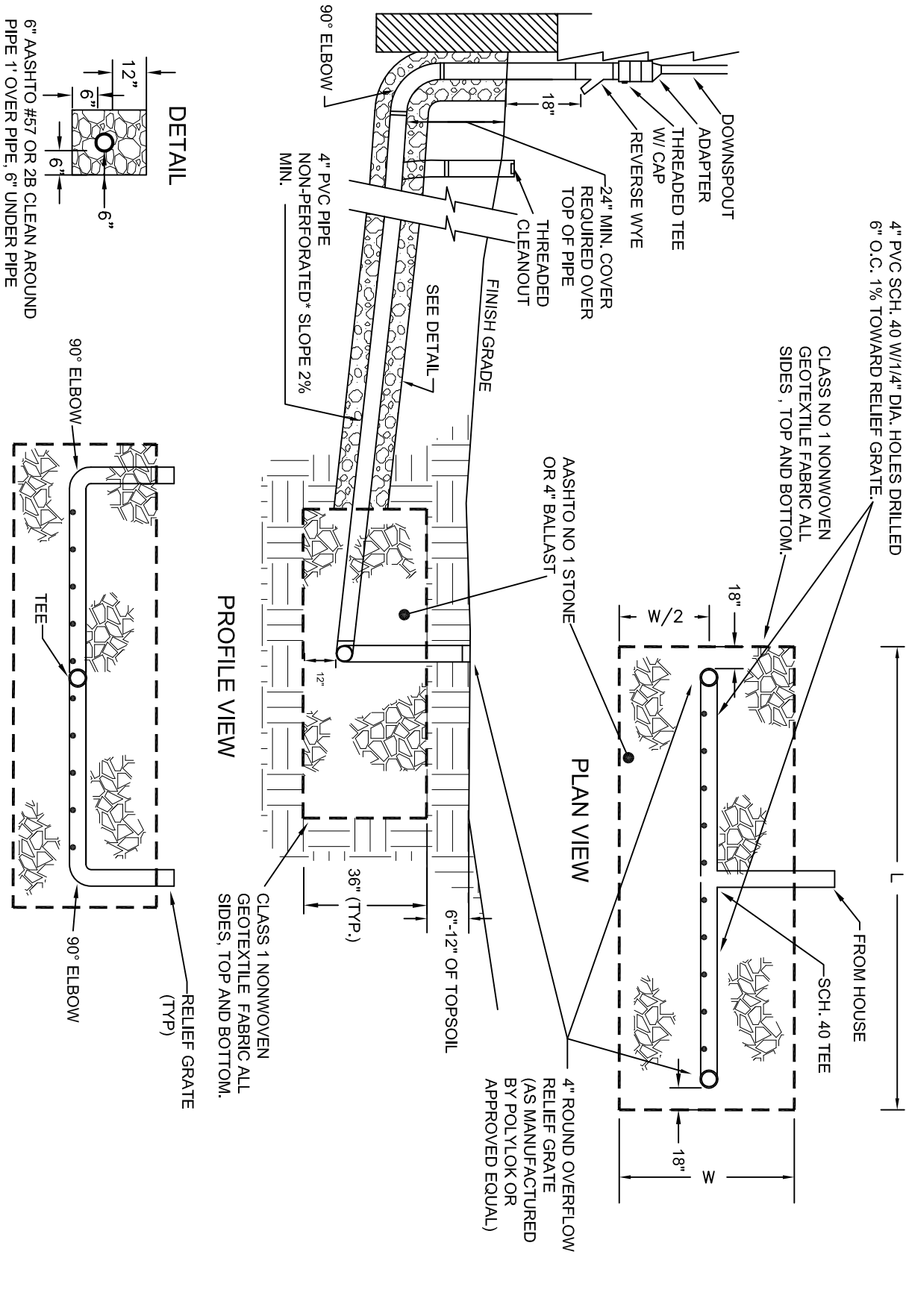

DOWNSPOUT SEEPAGE BED RUN OFF CAPTURE CALCULATION

NEW SITE IMPERVIOUS AREA-(a)X SQ. FT.
 RUN OFF CAPTURE STORAGE REQUIRED-(a)X SQ. FT./6=(b) Y CUBIC FT. OF CAPTURE VOLUME
 SEEPAGE BED DESIGN-(b)Y CUBIC FEET OF CAPTURE VOLUME REQUIRED X 2.5 (TOTAL
 VOLUME/VOIDS FOR AASHTO #1 [4" STONE] BALLAST)= (c) Z CUBIC FT SEEPAGE BED VOLUME
 C=0.417a

NOTES:

1. ALL PIPE IS 4" SCHEDULE 40 (NON-PERFORATED, SOLID CORE) PVC UNLESS OTHERWISE SPECIFIED.
2. LENGTH, WIDTH AND DEPTH TO BE DETERMINED PER DESIGN AND FIELD CONDITIONS.
3. PROVIDE CLEANOUTS EVERY 100 FT. AND AT EACH CHANGE IN DIRECTION GREATER THAN 45 DEGREES. CLEANOUTS TO BE SET FLUSH WITH FINISHED GRADE.

**UPPER DUBLIN TOWNSHIP STANDARD DETAIL
 DOWNSPOUT SEEPAGE BED DETAIL**



DATE

10-2013

NOT TO SCALE

DR343

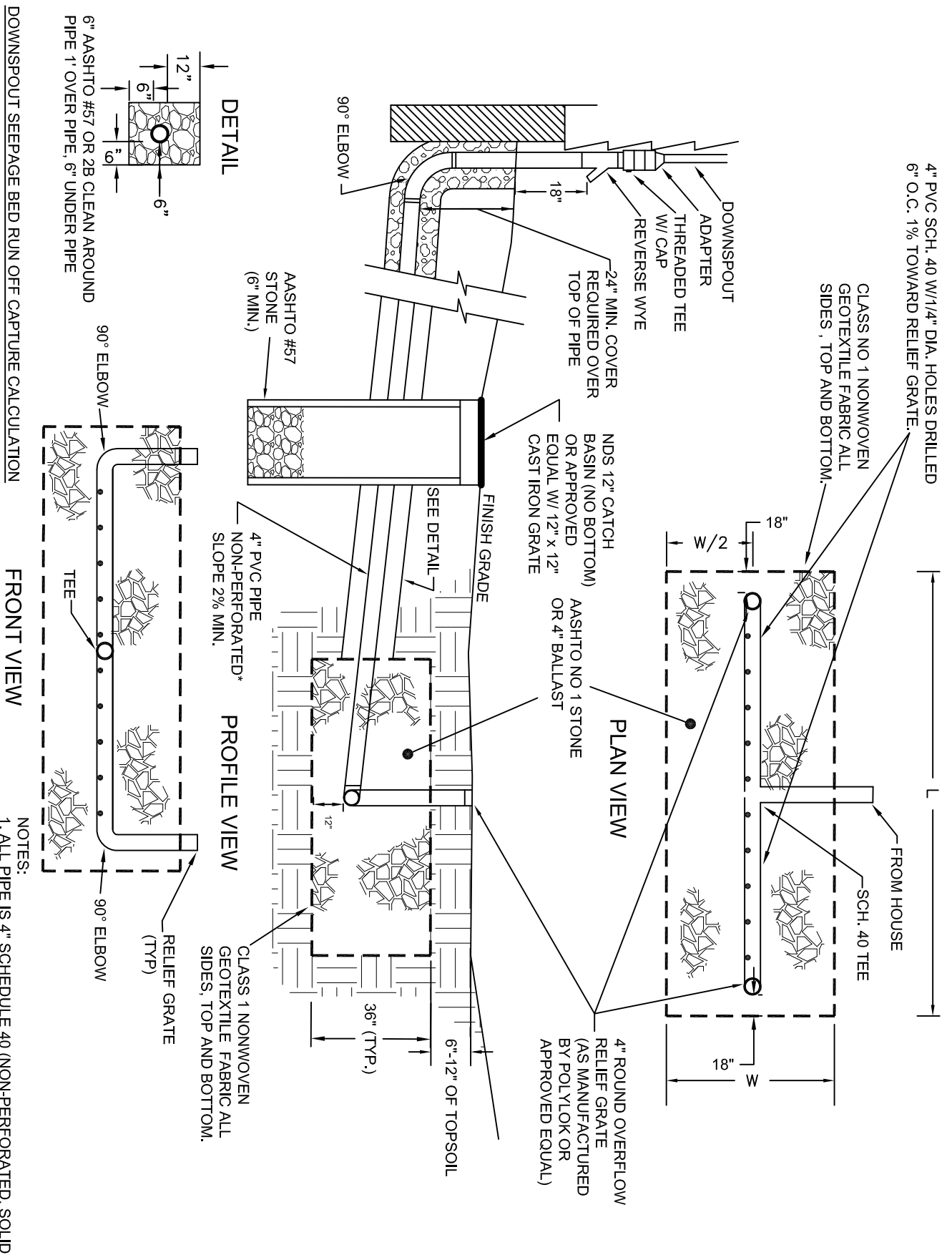

NEW SITE IMPERVIOUS AREA-(a)X SQ. FT.
 RUN OFF CAPTURE STORAGE REQUIRED- (a)X SQ. FT./ 6=(b) Y CUBIC FT. OF CAPTURE VOLUME
 SEEPAGE BED DESIGN-(b)Y CUBIC FEET OF CAPTURE VOLUME REQUIRED X 2.5 (TOTAL
 VOLUME/ VOIDS FOR AASHTO #1 [4" STONE] BALLAST)= (c) Z CUBIC FT SEEPAGE BED VOLUME
 C=0.417a

DOWNSPOUT SEEPAGE BED RUN OFF CAPTURE CALCULATION

FRONT VIEW

PROFILE VIEW

PLAN VIEW

NOTES:
 1. ALL PIPE IS 4" SCHEDULE 40 (NON-PERFORATED, SOLID
 CORE) PVC UNLESS OTHERWISE SPECIFIED.
 2. LENGTH, WIDTH AND DEPTH TO BE DETERMINED
 PER DESIGN AND FIELD CONDITIONS.
 3. PROVIDE CLEANOUTS EVERY 100 FT. AND AT EACH
 CHANGE IN DIRECTION GREATER THAN 45 DEGREES.
 CLEANOUTS TO BE SET FLUSH WITH FINISHED GRADE.

UPPER DUBLIN TOWNSHIP STANDARD DETAIL
 ALTERNATE DOWNSPOUT SEEPAGE BED DETAIL

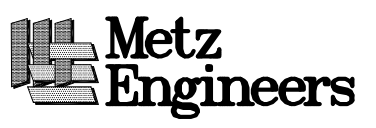

DATE

10-2013

NOT TO SCALE

DR343-2

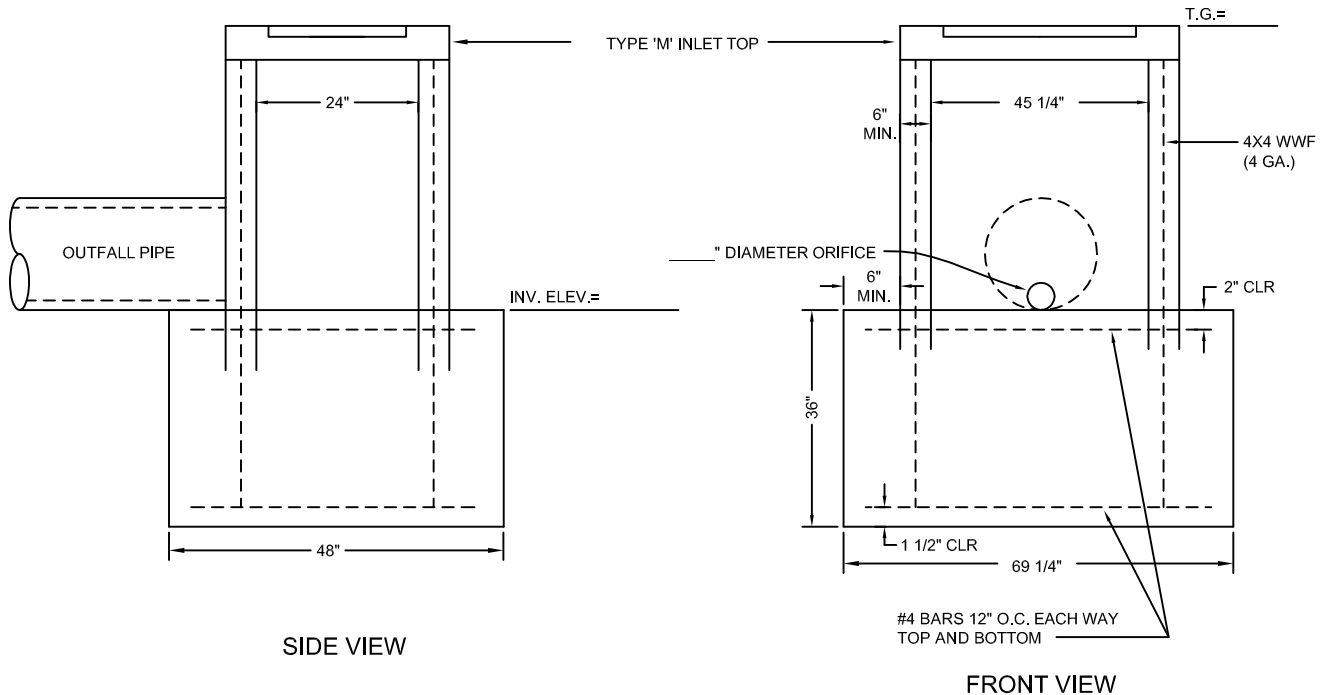

NOTES

1. CONSTRUCTION REQUIREMENTS
 - A. CONSTRUCT IN ACCORDANCE WITH: PENNDOT 408, CURRENT EDITION, SECTIONS 605, 606, 714; PENNDOT RC STANDARDS, RC 46M, CURRENT EDITION AND AS MODIFIED HEREIN.
 - B. MINIMUM CONCRETE COMPRESSIVE STRENGTH:

CAST-IN-PLACE	CLASS AA MODIFIED DESIGN
	COMPRESSIVE STRENGTH (4000 PSI).
PRECAST	CLASS AA MODIFIED DESIGN
	COMPRESSIVE STRENGTH (4000 PSI).
 - C. PROVIDE STEEL REINFORCEMENT IN ACCORDANCE WITH SEC. 709. PROVIDE MINIMUM YIELD STRENGTH OF 60,000 P.S.I.
 - D. CLEAR COVER FOR STEEL:

WALLS:	CAST-IN-PLACE	2"
	PRECAST	1 1/2"
FOOTINGS:	CAST-IN-PLACE	2 1/2" (TOP BARS)
		3" (BOTTOM BARS)
	PRECAST	2" (TOP BARS)
		2" (SIDE COVER)
		1 1/2" (BOTTOM BARS)
SLABS:	CAST-IN-PLACE	2" (TOP AND BOTTOM BARS)
		1 1/2" (SIDE COVER)
2. INLET DESIGN TO MEET HS 25 LIVE LOADING.
3. THE SELECTION OF COMPONENTS TO ACHIEVE A SPECIFIED INLET ASSEMBLY IS THE CONTRACTORS RESPONSIBILITY
4. USE ONE PRECAST CONCRETE GRADE ADJUSTMENT RING (3"MIN.-10" MAX.) WHEN REQUIRED, AND NON SHRINK GROUT.
5. FOR BASE SECTION REINFORCEMENT: PROVIDE REINFORCEMENT PER PENNDOT RC STANDARDS, RC 46M, CURRENT EDITION.
6. FOR RISER SECTION REINFORCEMENT: PROVIDE REINFORCEMENT PER PENNDOT RC STANDARDS, RC 46M, CURRENT EDITION.
7. FRAMES AND GRATES SHALL BE PADOT TYPE C STRUCTURAL STEEL.
8. GRATES SHALL BE PADOT "BICYCLE SAFE".
9. CONSTRUCT INLETS THAT EXCEED 5 FEET IN HEIGHT WITH STEPS SIMILAR TO MANHOLES.
10. INLETS THAT ARE NOT MONOLITHIC REQUIRE CONSTRUCTION JOINTS OR KEYS FOR RISER SECTIONS.
11. MASTIC OR NON SHRINK GROUT REQUIRED AT ALL CONSTRUCTION JOINTS OR KEYS.

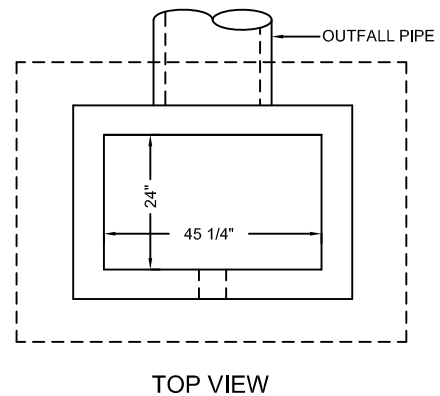

**UPPER DUBLIN TOWNSHIP STANDARD DETAIL
PRECAST OUTLET STRUCTURE**



DATE 10-2013

NOT TO SCALE

DR344

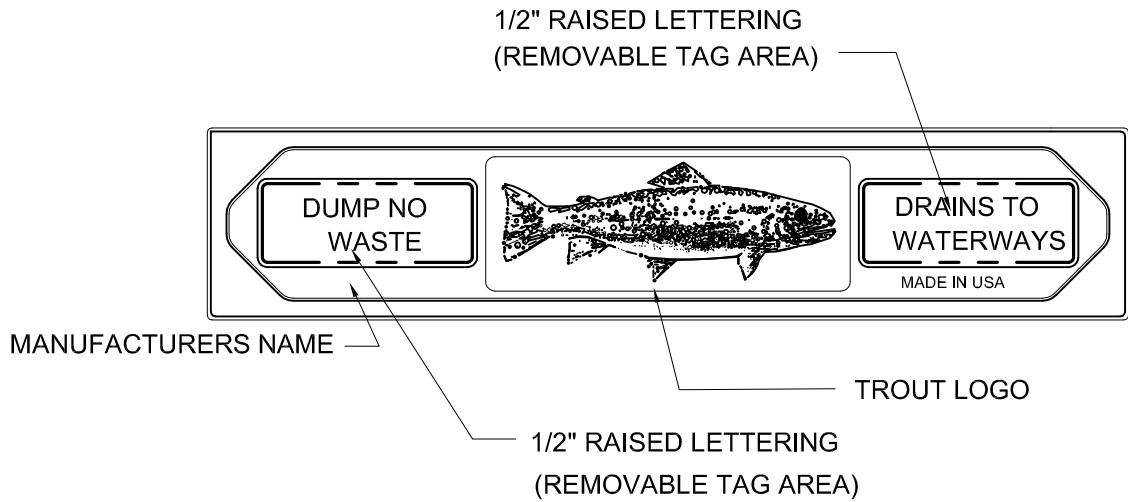

NOTE:

1. PROVIDE TROUT LOGO PLATE AS MANUFACTURED BY EAST JORDAN IRON WORKS. (PRODUCT NO. 00700160 DIPPED) OR APPROVED EQUAL.

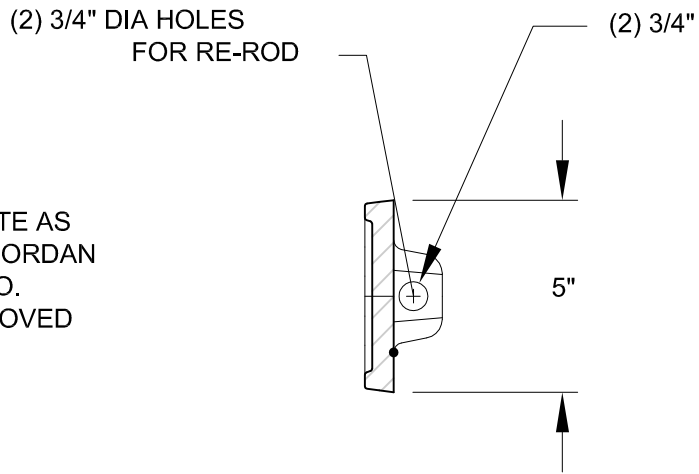

CROSS SECTION

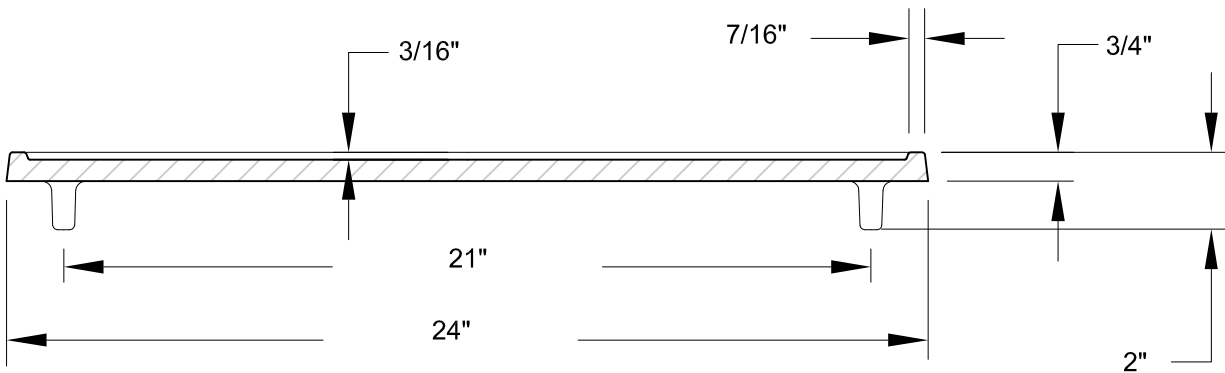

CROSS SECTION

UPPER DUBLIN TOWNSHIP STANDARD DETAIL
TROUT LOGO PLATE
 (FOR TYPE 'C', 4' AND 6' SPECIAL INLETS)



DATE 10-2013

NOT TO SCALE

DR345

1/2" RAISED LETTERING
(REMOVABLE TAG AREA)

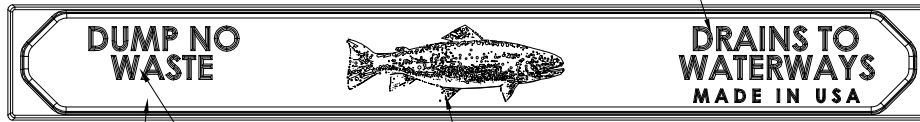

MANUFACTURERS NAME

TROUT LOGO

1/2" RAISED LETTERING
(REMOVABLE TAG AREA)

(2) 3/4" DIA HOLES
FOR RE-ROD

NOTE:

- 1. PROVIDE TROUT LOGO PLATE AS MANUFACTURED BY EAST JORDAN IRON WORKS. (PRODUCT NO. 00700360 DIPPED) OR APPROVED EQUAL.

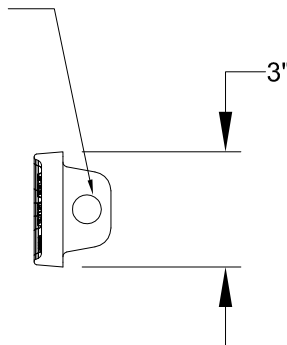

END VIEW

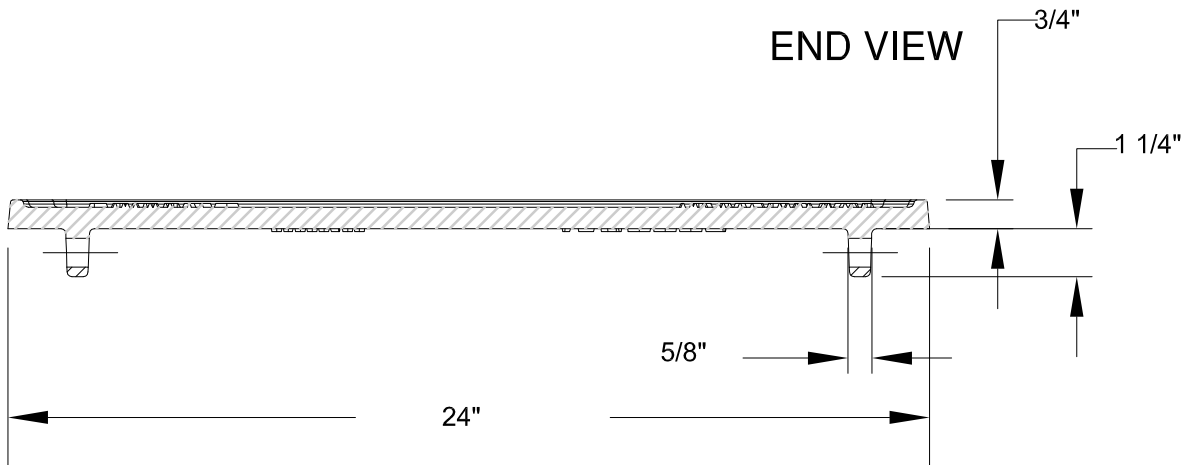

CROSS SECTION

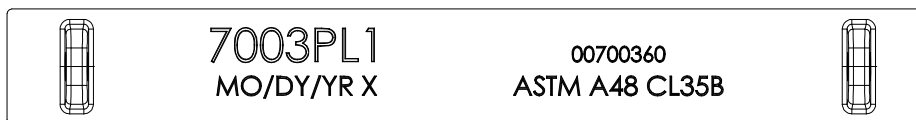

BOTTOM VIEW

UPPER DUBLIN TOWNSHIP STANDARD DETAIL
TROUT LOGO PLATE
(FOR TYPE 'M' INLETS)



DATE

10-2013

NOT TO SCALE

DR346

REQUIRED FOR
ALL STORM
STRUCTURES,
INLETS, MANHOLES,
ENDWALLS, ETC.
(INLET SHOWN)

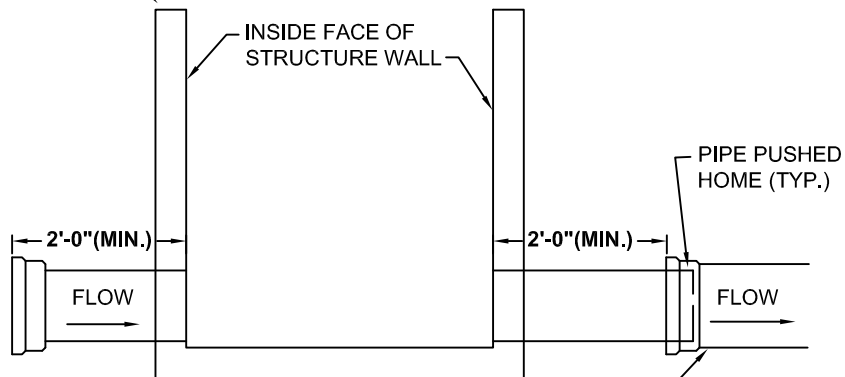

BELL AND SPIGOT PIPE
SHOWN.
(REQUIRED FOR ALL STORM
PIPE. BELL AND SPIGOT,
TONGUE AND GROOVE ETC.
ROUND AND ELLIPTICAL.)

UPPER DUBLIN TOWNSHIP STANDARD DETAIL
MINIMUM PIPE LENGTH FOR STORM TIE IN TO STRUCTURES



DATE

10-2013

NOT TO SCALE

DR347

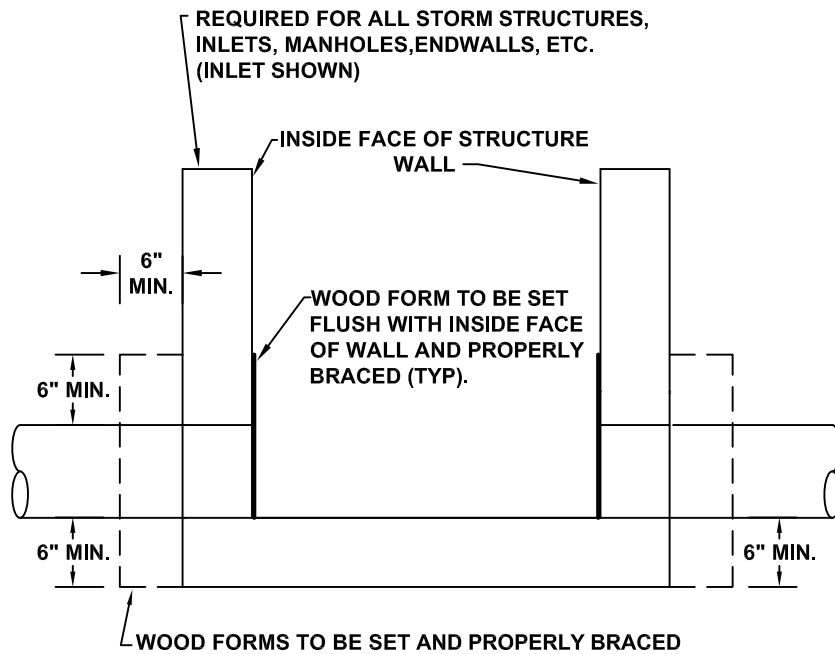

NOTES

1. ALL PENETRATIONS/OPENINGS AROUND THE PIPES(S) MUST BE FORMED AND FILLED WITH CLASS AA (3750 PSI MINIMUM COMPRESSIVE STRENGTH) CEMENT CONCRETE. CONCRETE MUST BE VIBRATED WITH A VIBRATOR TO FILL THE OPENING(S) AND ELIMINATE VOIDS.
2. FORMS SHALL BE SET A MINIMUM OF 6" ALL THE WAY AROUND THE PIPE(S). LARGER OPENINGS SUCH AS CORNER PENETRATIONS WILL REQUIRE REINFORCED CONCRETE WALLS TO BE INSTALLED IN THE FIELD. USE THE SAME REINFORCEMENT USED IN THE MANUFACTURING OF THE STRUCTURE. ALL REINFORCEMENT TO BE DOWELED (4" DEEP MIN.) INTO EXISTING WALLS.

UPPER DUBLIN TOWNSHIP STANDARD DETAIL
 SEALING OF PENETRATIONS/OPENINGS
 AROUND PIPE(S)



DATE

10-2013

NOT TO SCALE

DR348

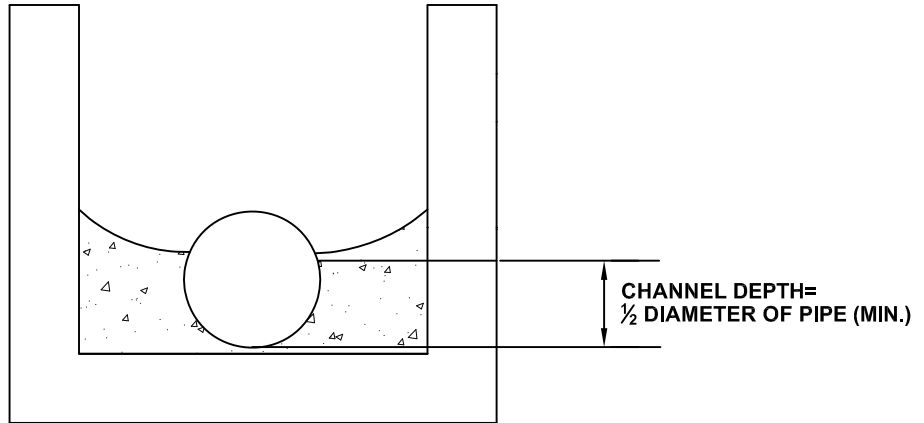

FRONT VIEW

CONCRETE SHALL BE
CLASS AA (3750 PSI)
MINIMUM COMPRESSIVE
STRENGTH

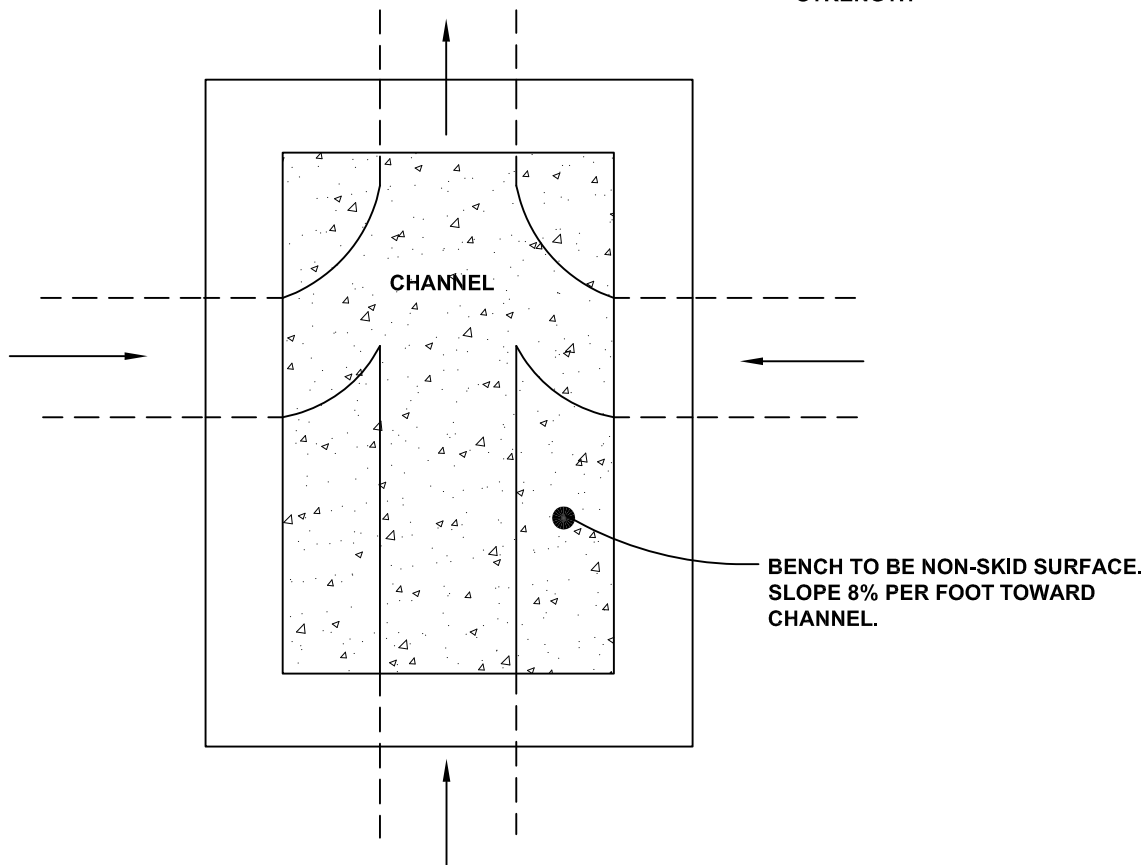

TOP VIEW

UPPER DUBLIN TOWNSHIP STANDARD DETAIL
INLET CHANNELS



DATE

10-2013

NOT TO SCALE

DR349

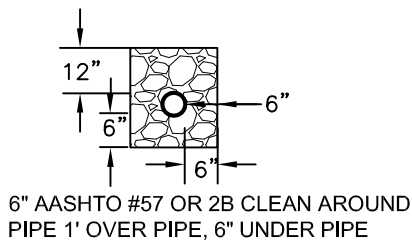
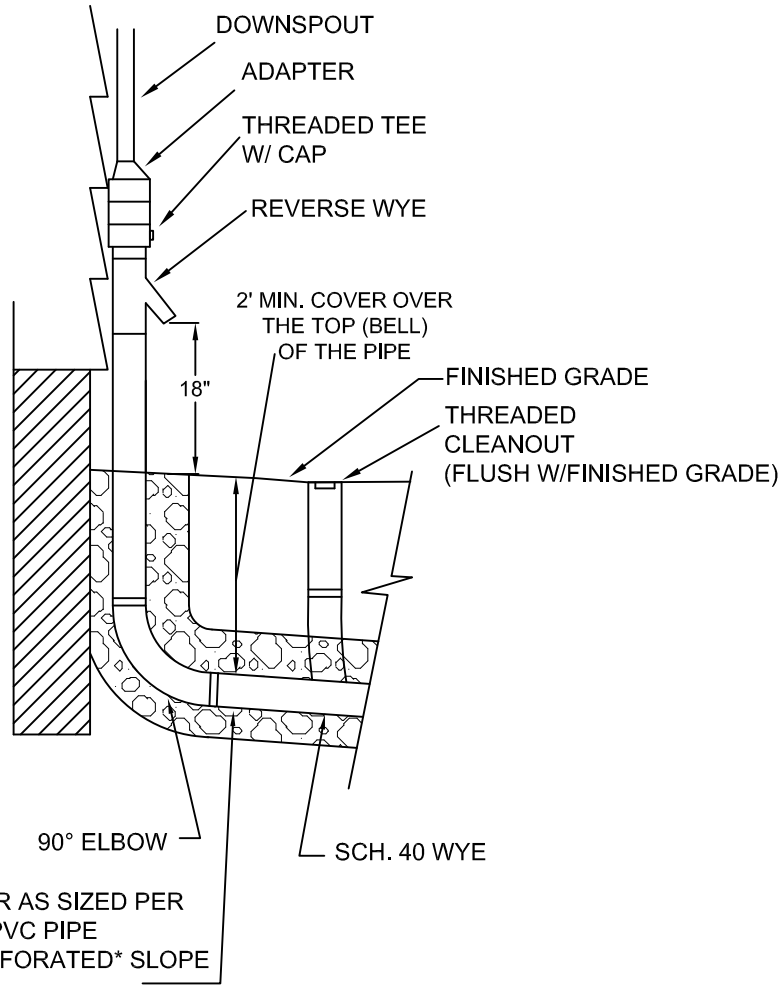

BEDDING DETAIL

NOTES:

1. ALL PIPE IS 4" MINIMUM OR AS SIZED PER DESIGN. PIPE SHALL BE SCHEDULE 40 (NON-PERFORATED, SOLID CORE) PVC, HDPE N-12 WITH BELL AND SPIGOT JOINTS OR SDR 35 PVC WITH GASKETED JOINTS UNLESS OTHERWISE SPECIFIED.
2. PROVIDE CLEANOUTS EVERY 100 FT. AND AT EACH CHANGE IN DIRECTION GREATER THAN 45 DEGREES. CLEANOUTS TO BE SET FLUSH WITH FINISHED GRADE.
3. ALL PIPE SHALL HAVE A MINIMUM OF 2' COVER OVER THE TOP (BELL) OF THE PIPE(S).

**UPPER DUBLIN TOWNSHIP STANDARD DETAIL
DOWNSPOUT AND ROOF DRAIN DETAIL**



DATE

10-2013

NOT TO SCALE

DR350

STANDARD CONSTRUCTION DETAIL #19
Standard Filter Fabric Fence (18" High)

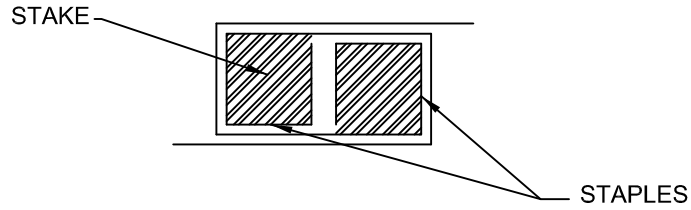

JOINING FENCE SECTIONS

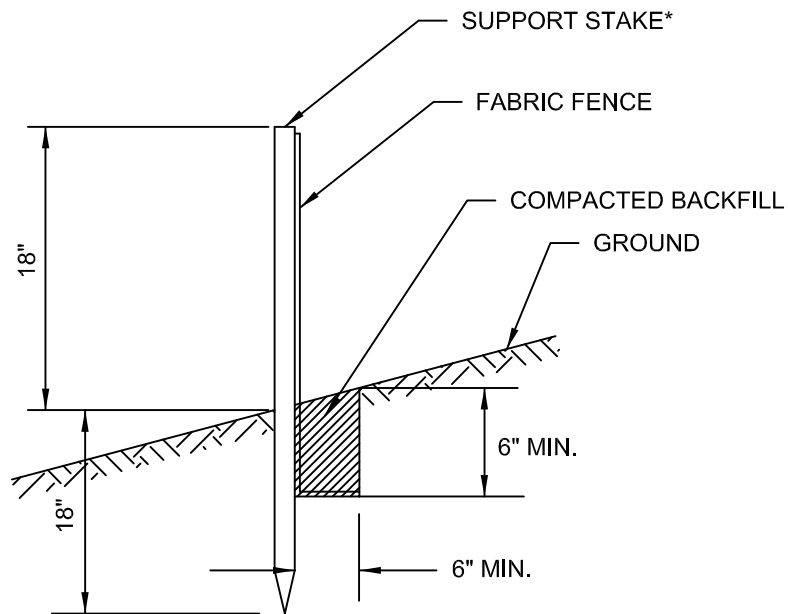

* Stakes spaced @ 8' maximum. Use 2" x 2" wood or equivalent steel stakes.

Filter Fabric Fence must be placed at level existing grade. Both ends of the barrier must be extended at least 8 feet up slope at 45 degrees to the main barrier alignment.

Sediment must be removed when accumulations reach 1/2 the above ground height of the fence.

Any section of Filter Fabric Fence which has been undermined or topped must be immediately replaced with a Rock Filter Outlet. See Standard Construction Detail #18. (See Upper Dublin Township Standard Detail ES 403).

UPPER DUBLIN TOWNSHIP STANDARD DETAIL
18" STANDARD FILTER FABRIC FENCE



DATE 10-2013

NOT TO SCALE

ES 400

**STANDARD CONSTRUCTION DETAIL #20
Reinforced Filter Fabric Fence (30" High)**

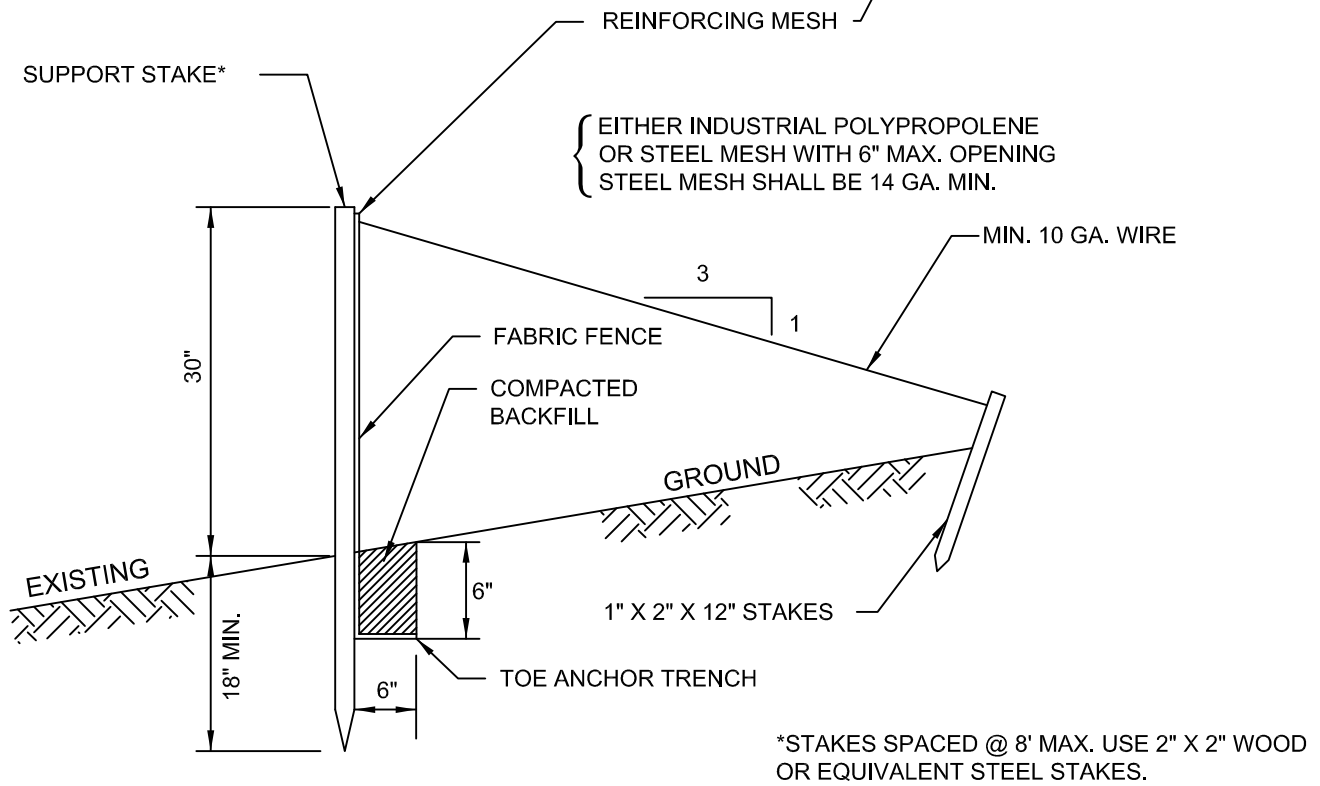
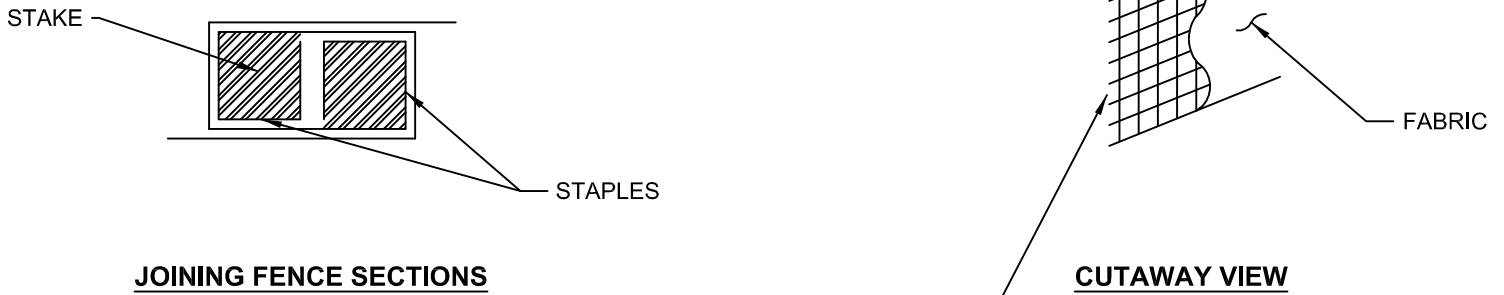

NOTE: SHOW ALL DETAILS AND CONSTRUCTION DIMENSIONS ON PLAN DRAWINGS.

Filter Fabric Fence must be installed at existing level grade. Both ends of each fence section must be extended at least 8 feet upslope at 45 degrees to the main fence alignment.

Sediment must be removed where accumulations reach 1/2 the above ground height of the fence.

Any fence section which has been undermined or topped must be immediately replaced with a Rock Filter Outlet. See Standard Construction Detail #18. (See Upper Dublin Township Standard Detail ES 403).

**UPPER DUBLIN TOWNSHIP STANDARD DETAIL
30" REINFORCED FILTER FABRIC FENCE**

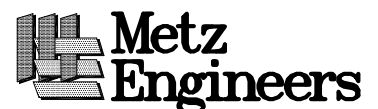

DATE 10-2013

NOT TO SCALE

ES 401

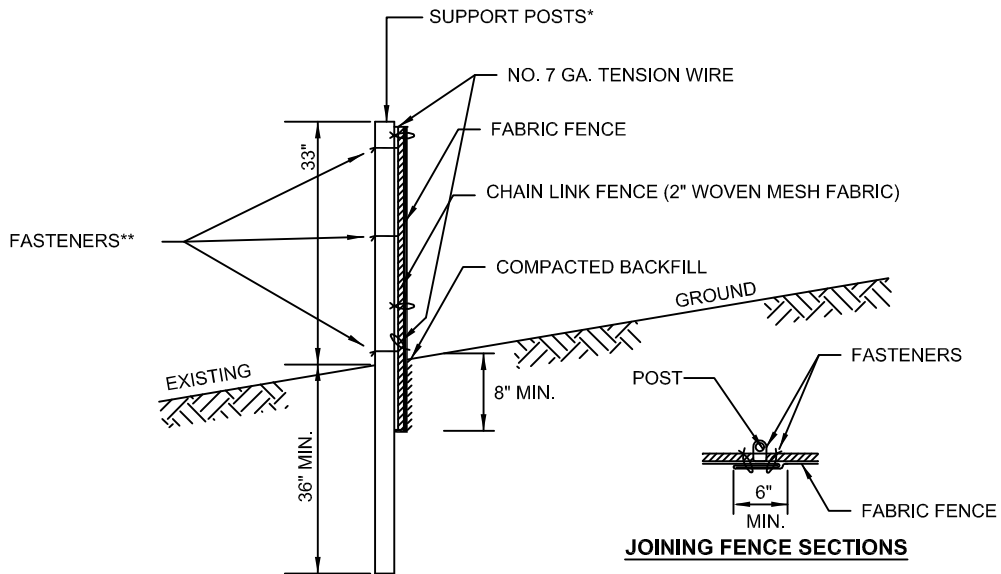

* POSTS SPACED @ 10' MAX. USE 2 1/2" DIA. GALVANIZED OR ALUMINUM POSTS.

** CHAIN LINK TO POST FASTENERS SPACED @ 14" MAX. USE NO. 6 GA. ALUMINUM WIRE OR NO. 9 GALVANIZED STEEL PRE-FORMED CLIPS. CHAIN LINK TO TENSION WIRE FASTENERS SPACED @ 60" MAX. USE NO. 10 GA. GALVANIZED STEEL WIRE. FABRIC TO CHAIN FASTENERS SPACED @ 24" MAX. C TO C.

NO. 7 GA. TENSION WIRE INSTALLED HORIZONTALLY AT TOP AND BOTTOM OF CHAIN-LINK FENCE.

FILTER FABRIC FENCE MUST BE PLACED AT EXISTING LEVEL GRADE. BOTH ENDS OF THE BARRIER MUST BE EXTENDED AT LEAST 8 FEET UPSLOPE AT 45 DEGREES TO THE MAIN BARRIER ALIGNMENT.

SEDIMENT MUST BE REMOVED WHEN ACCUMULATIONS REACH 1/2 THE ABOVE GROUND HEIGHT OF THE FENCE.

UPPER DUBLIN TOWNSHIP STANDARD DETAIL
SUPER SILT FENCE



DATE 10-2013

NOT TO SCALE

ES402

**STANDARD CONSTRUCTION DETAIL #18
Rock Filter Outlets**

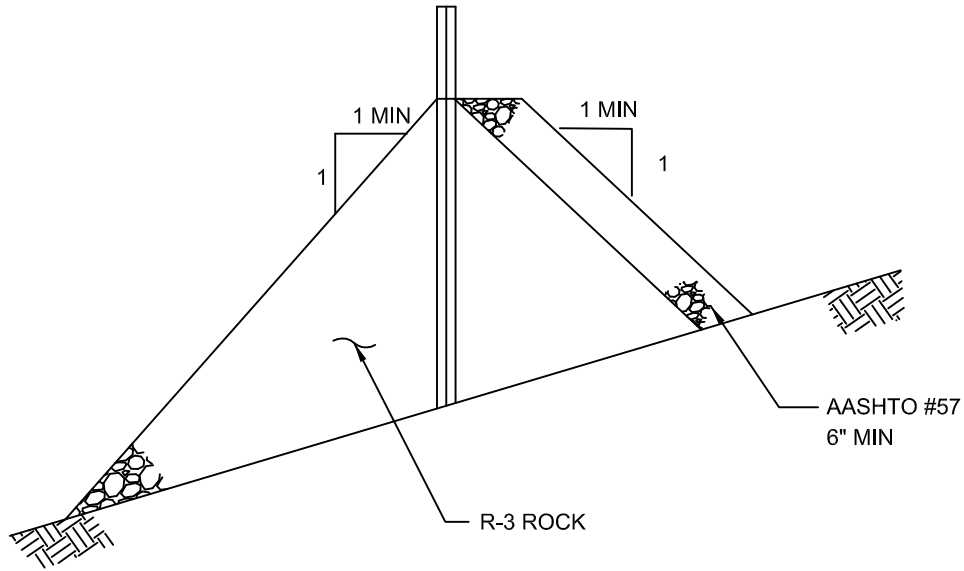

OUTLET CROSS-SECTION

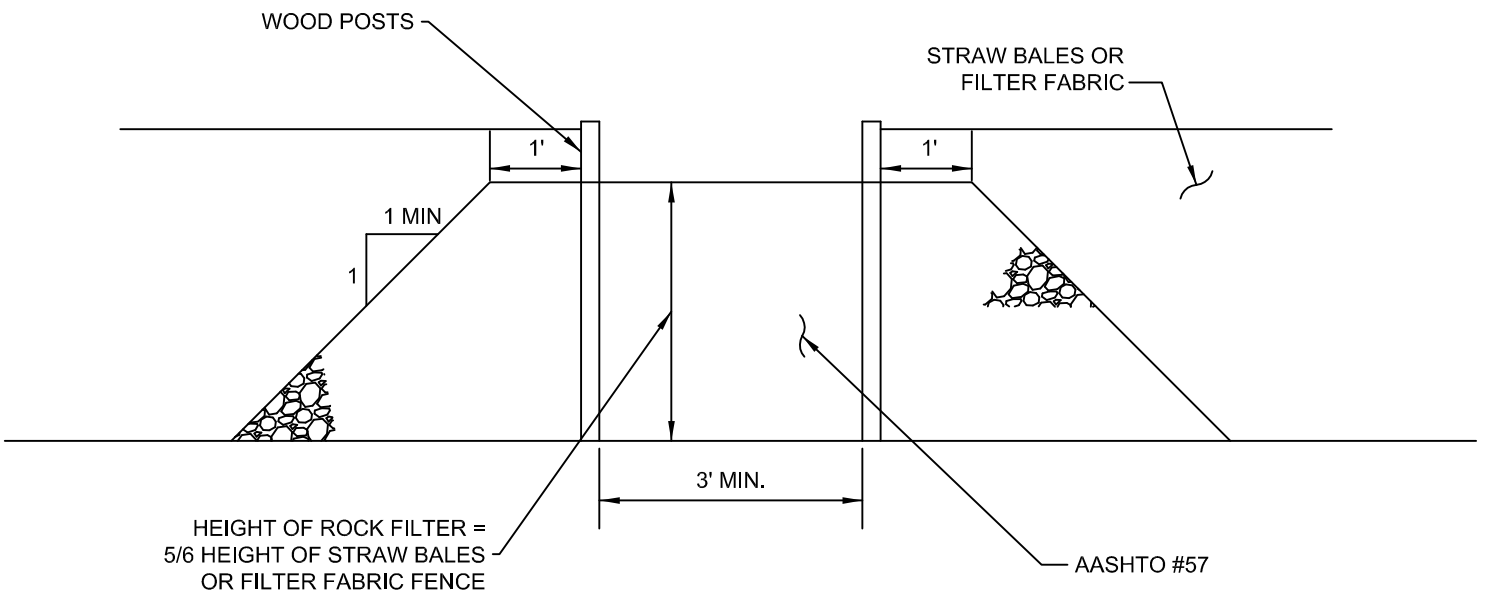

UP-SLOPE FACE

MAINTENANCE OF STONE FILTERS:
 STONE FILTERS SHALL BE INSPECTED WEEKLY AND AFTER EACH RAIN EVENT. ACCUMULATED SEDIMENT AND DEBRIS SHALL BE REMOVED FROM THE UPSLOPE FACE (INFLOW SIDE) OF THE STONE FILTER WHEN ACCUMULATIONS REACH 1/3 THE HEIGHT OF THE OUTLET OR AS DIRECTED BY THE COUNTY CONSERVATION DISTRICT AND/OR THE TOWNSHIP REPRESENTATIVE, RESPECTFULLY. A SUFFICIENT STOCKPILE OF AASHTO #1 AND AASHTO #57 STONE MUST BE AVAILABLE ON SITE TO REPLENISH STONE FILTER(S) AS NECESSARY OR REQUIRED.

**UPPER DUBLIN TOWNSHIP STANDARD DETAIL
ROCK FILTER OUTLETS**



DATE

10-2013

NOT TO SCALE

ES 403

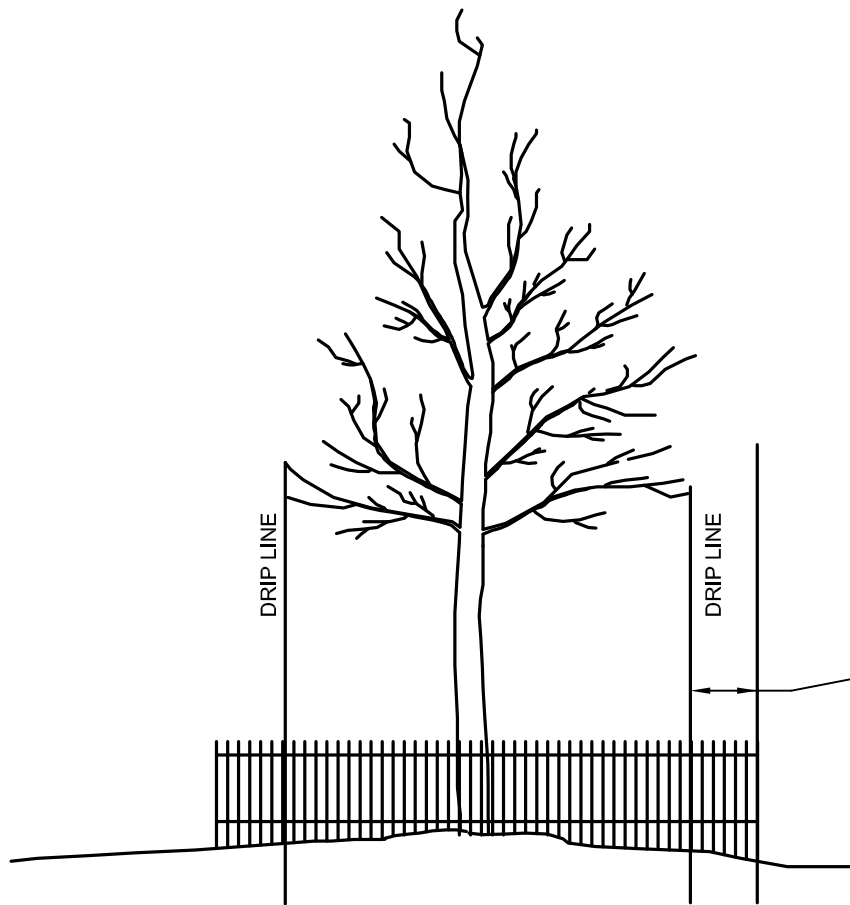

4" HIGH SAFETY FENCE TO BE SET 5' MIN. OUTSIDE OF DRIP LINE OR 20' FROM THE TRUNK WHICHEVER IS GREATER.
 4" HIGH SAFETY FENCE TO BE FLUORESCENT YELLOW-GREEN OR HIGH VISIBILITY ORANGE AS MANUFACTURED BY TENAX OR APPROVED EQUAL.

FENCE TO BE STAKED AT LEAST EVERY 10'

**UPPER DUBLIN TOWNSHIP STANDARD DETAIL
 TREE PROTECTION FENCE**

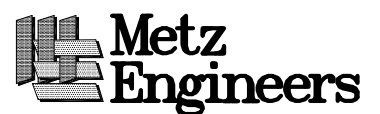

DATE

10-2013

NOT TO SCALE

ES404

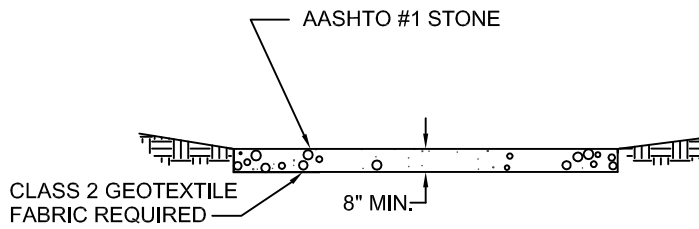
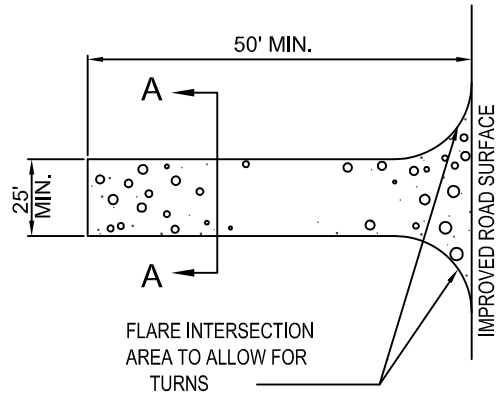

SECTION A-A

MAINTENANCE: THE STRUCTURE'S THICKNESS WILL BE CONSTANTLY MAINTAINED TO THE SPECIFIED DIMENSION BY ADDING AASHTO #1 STONE. A STOCKPILE OF AASHTO #1 STONE SHALL BE KEPT ON THE SITE FOR THIS PURPOSE. ALL ROADWAYS MUST BE KEPT CLEAN AT ALL TIMES. ANY SEDIMENT LOOSE STONE ETC. MUST BE CLEANED FROM ROADS IMMEDIATELY AND RETURNED TO THE CONSTRUCTION SITE.

UPPER DUBLIN TOWNSHIP STANDARD DETAIL
ROCK CONSTRUCTION ENTRANCE



DATE

10-2013

NOT TO SCALE

ES405

CLASS 2 GEOTEXTILE MATERIAL
PENNDOT SPECIFICATION PUBLICATION
408 CURRENT EDITION SEC. 212.3(c).

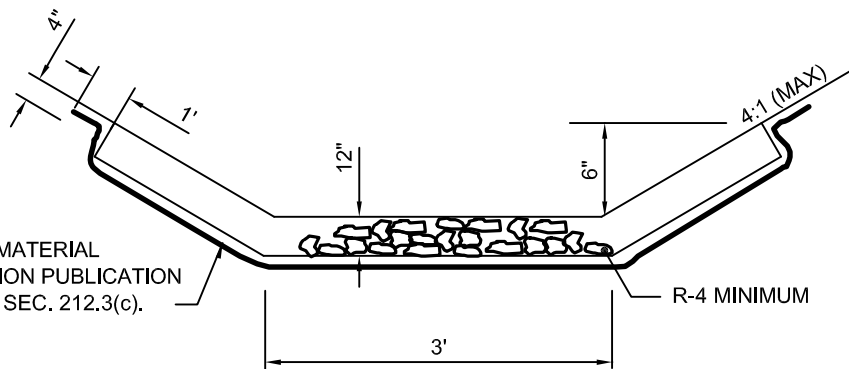

UPPER DUBLIN TOWNSHIP STANDARD DETAIL
CROSS-SECTION RIP RAP LINED LOW FLOW CHANNEL



DATE

10-2013

NOT TO SCALE

ES406

Sediment Basins

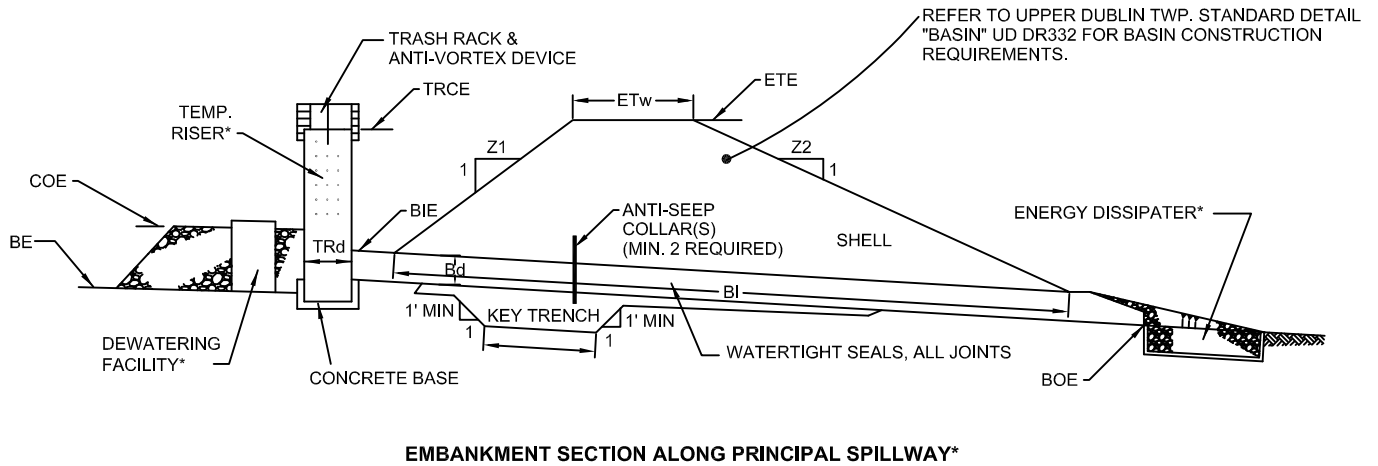

BASIN NO.	Z1 (FT)	Z2 (FT)	TEMPORARY RISER			BARREL					EMBANKMENT		CLEAN OUT ELEV COE (FT)	BOTTOM ELEV BE (FT)	
			DIA TRd (IN)	CREST ELEV TRCE (FT)	MAT'L	DIA Bd (IN)	INLET ELEV BIE (FT)	MAT'L	LENGTH BI (FT)	OUTLET ELEV BOE (FT)	TOP ELEV ETE (FT)	TOP WIDTH ETw (FT)			

* Also refer to Sediment Basin Temporary Riser, Emergency Spillway, Energy Dissipater, Trash Rack & Anti-vortex Device, and Sediment Storage Dewatering Facility Details.

A clean out stake shall be placed near the center of each basin. Accumulated sediment shall be removed when it has reached the clean out elevation on the stake.

UPPER DUBLIN TOWNSHIP STANDARD DETAIL SEDIMENT BASINS



DATE 10-2013

NOT TO SCALE

ES407

Sediment Basin Temporary Riser & Permanent Structure*

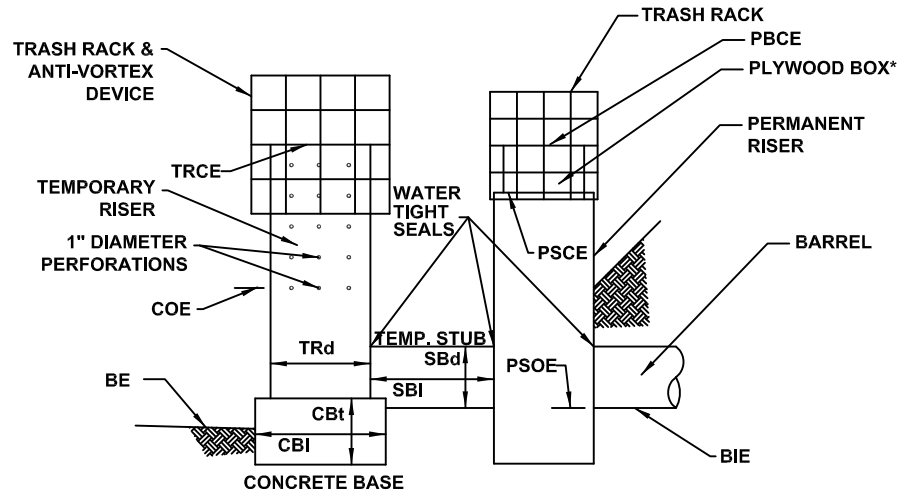

BASIN NO.	TEMPORARY RISER			PERFORATIONS		CONCRETE BASE			BARREL
	DIA TRd (IN)	CREST ELEV TRCE (FT)	MAT'L	NO. HOLES PER ROW	VERTICAL SPACING OF ROWS (FT)	LENGTH CBI (IN)	WIDTH CBw (IN)	THICK. CBt (IN)	INLET ELEV BIE (FT)

BASIN NO.	TEMPORARY STUB				PERMANENT STRUCTURE			
	DIA SBd (IN)	INVERT ELEV SBIE (FT)	MAT'L	LENGTH SBI (FT)	CREST ELEV PSCE (FT)	OPENING LENGTH PSOI (IN)	OPENING WIDTH PSOW (IN)	OUTLET ELEV PSOE (FT)

* See Trash Rack & Anti-vortex Device and Plywood Box Details.



Sediment Basins With Permanent Storm Water Structures*

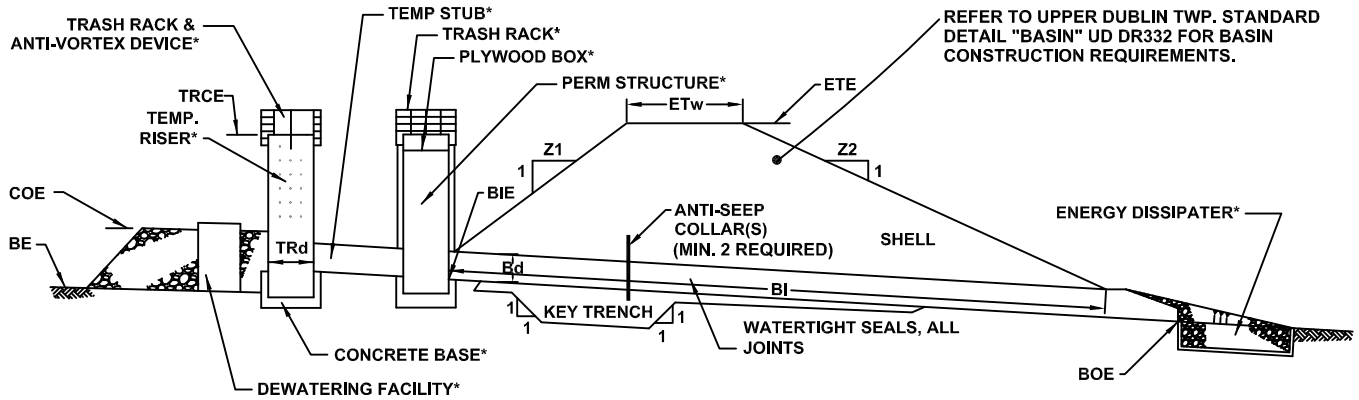

EMBANKMENT SECTION ALONG PRINCIPAL SPILLWAY*

BASIN NO.	Z1 (FT)	Z2 (FT)	TEMPORARY RISER			BARREL					EMBANKMENT		CLEAN OUT ELEV COE (FT)	BOTTOM ELEV BE (FT)	
			DIA TRd (IN)	CREST ELEV TRCE (FT)	MAT'L	DIA Bd (IN)	INLET ELEV BIE (FT)	MAT'L	LENGTH BI (FT)	OUTLET ELEV BOE (FT)	TOP ELEV ETE (FT)	TOP WIDTH ETw (FT)			

* See Sediment Basin Temporary Riser & Permanent Structure, Emergency Spillway, Trash Rack & Anti-vortex Device, Energy Dissipater, and Sediment Storage Dewatering Facility Details.

A Clean Out Stake shall be placed near the center of each basin. Accumulated sediment shall be removed when it has reached the clean out level marked on the stake.

**UPPER DUBLIN TOWNSHIP STANDARD DETAIL
SEDIMENT BASINS WITH PERMANENT STORM WATER STRUCTURES**



DATE 10-2013

NOT TO SCALE

ES409

Sediment Basin Temporary Risers*

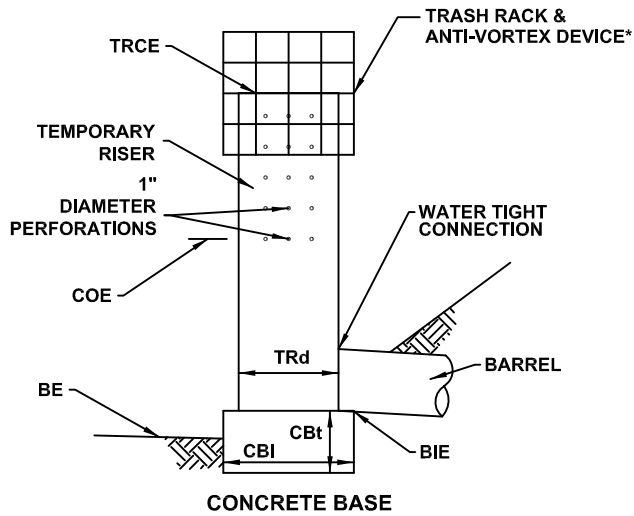

BASIN NO.	TEMPORARY RISER			PERFORATIONS		CONCRETE BASE		BARREL	
	DIA TRd (IN)	CREST ELEV TRCE (FT)	MAT'L	NO. HOLES PER ROW	VERTICAL SPACING OF ROWS (FT)	LENGTH CBI (IN)	WIDTH CBw (IN)	THICK. CBt (IN)	INLET ELEV BIE (FT)

* See Trash Rack & Anti-vortex Device Detail

**UPPER DUBLIN TOWNSHIP STANDARD DETAIL
SEDIMENT BASIN TEMPORARY RISERS**



DATE

10-2013

NOT TO SCALE

ES410

Plywood Boxes and Trash Racks for Permanent Structures

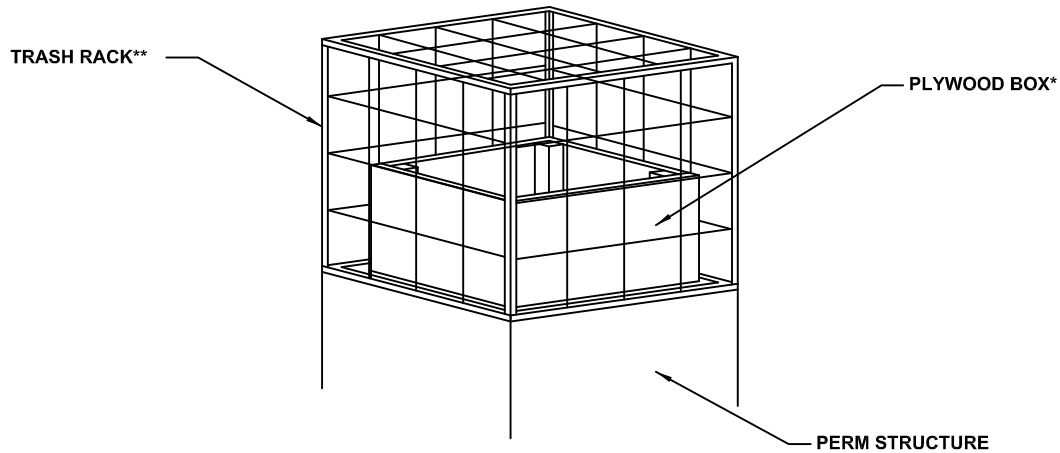

* $\frac{3}{4}$ " Marine grade plywood box with 2" x 2" pressure treated corner supports, set into 1 $\frac{1}{2}$ " grate offsets, caulk all seams to form watertight seals.

** Trash rack composed of 1" x 1" x $\frac{1}{8}$ " L (Typ.) and #4 Bars (Typ.) welded to the angles and at each intersection of the bars; #4 Bars spaced @ $\frac{1}{2}$ the diameter of the barrel max.

Plywood box must be bolted or strapped to the permanent riser.

Top of plywood box must be at least as high as temporary riser.

UPPER DUBLIN TOWNSHIP STANDARD DETAIL
PLYWOOD BOXES AND TRASH RACKS
FOR PERMANENT STRUCTURES



DATE

10-2013

NOT TO SCALE

ES411

Sediment Basin Emergency Spillways

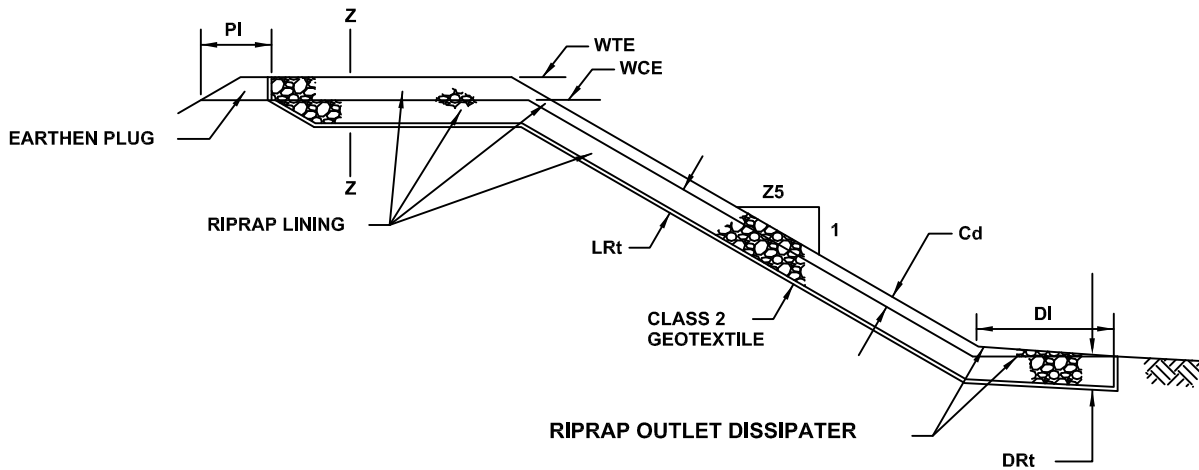
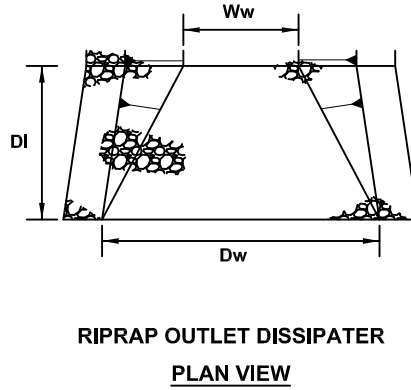
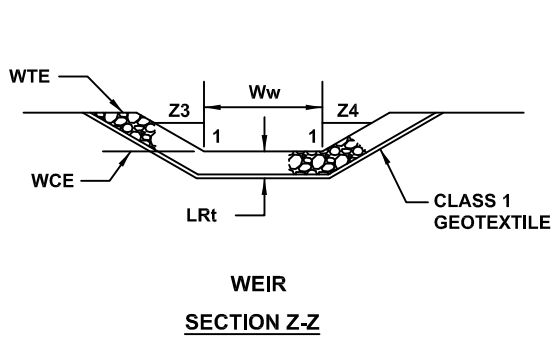

BASIN NO.	WEIR					LINING		CHANNEL		DISSIPATER			
	Z3 (FT)	Z4 (FT)	TOP ELEV WTE (FT)	CREST ELEV WCE (FT)	WIDTH Ww (FT)	RIPRAP SIZE (R-)	RIPRAP THICK. LRt (IN)	Z5 (FT)	DEPTH Cd (FT)	LENGTH DI (FT)	WIDTH Dw (FT)	RIPRAP SIZE (R-)	RIPRAP THICK. DRt (IN)

Dimension PI should be 5' minimum.

UPPER DUBLIN TOWNSHIP STANDARD DETAIL
TEMPORARY SEDIMENT BASIN EMERGENCY SPILLWAYS



DATE

10-2013

NOT TO SCALE

ES412

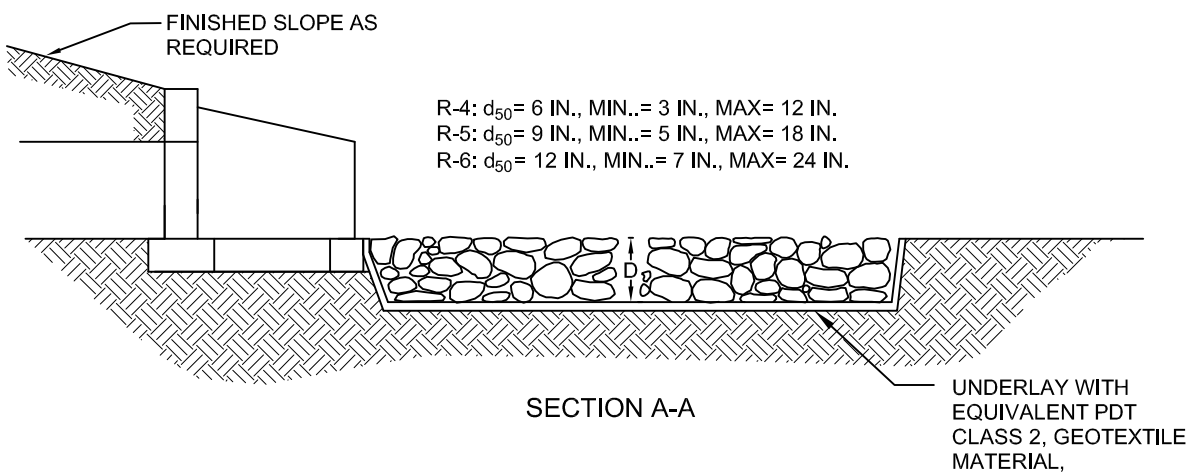
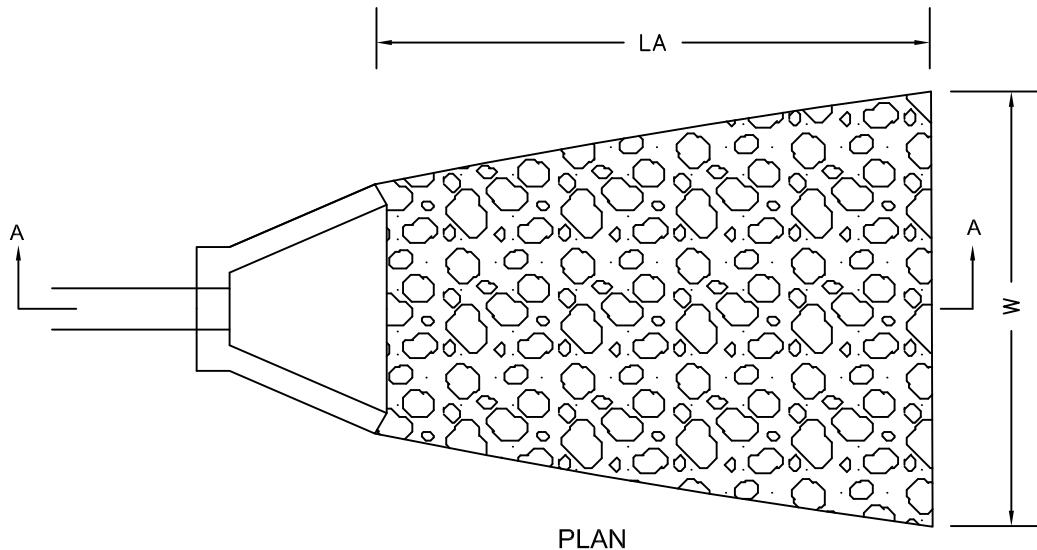

- R-4: d_{50} = 6 IN., MIN. = 3 IN., MAX = 12 IN.
- R-5: d_{50} = 9 IN., MIN. = 5 IN., MAX = 18 IN.
- R-6: d_{50} = 12 IN., MIN. = 7 IN., MAX = 24 IN.

END SECTION	PIPE DIA.	FLOW (Q) (CFS)	3Do	LA	W	D	RIP-RAP SIZE

NOTE: TO BE INSTALLED AT 0% SLOPE FOR ENTIRE LENGTH OF RIP-RAP

UPPER DUBLIN TOWNSHIP STANDARD DETAIL
RIP-RAP APRON & CHART



DATE

10-2013

NOT TO SCALE

ES413

PC 413.PDW

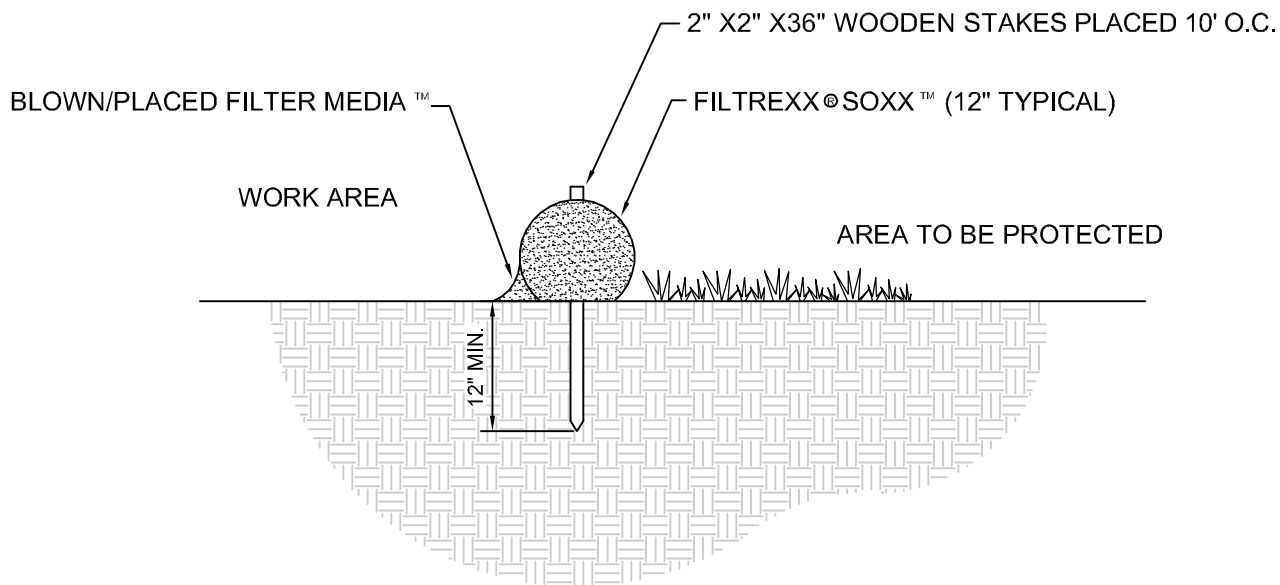

SECTION N.T.S.

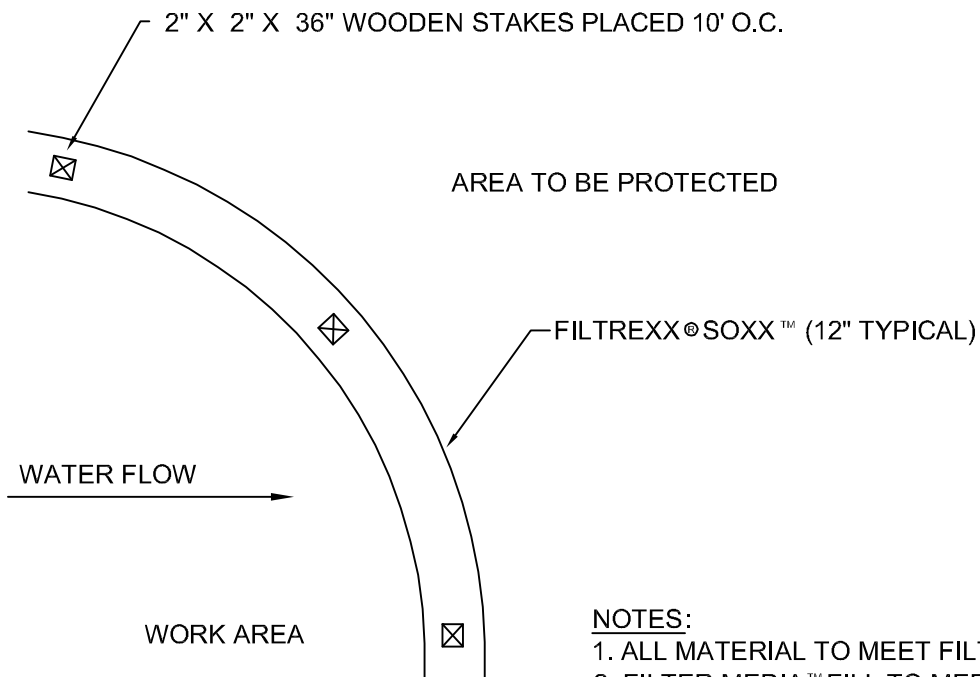

NOTES:

1. ALL MATERIAL TO MEET FILTREXX® SPECIFICATIONS.
2. FILTER MEDIA™ FILL TO MEET APPLICATION.
3. COMPOST MATERIAL TO BE DISPERSED ON SITE, AS DETERMINED BY ENGINEER.

PLAN N.T.S.

UPPER DUBLIN TOWNSHIP STANDARD DETAIL
FILTREXX® SOXX™ SEDIMENT CONTROL DETAIL



DATE

10-2013

NOT TO SCALE

ES414

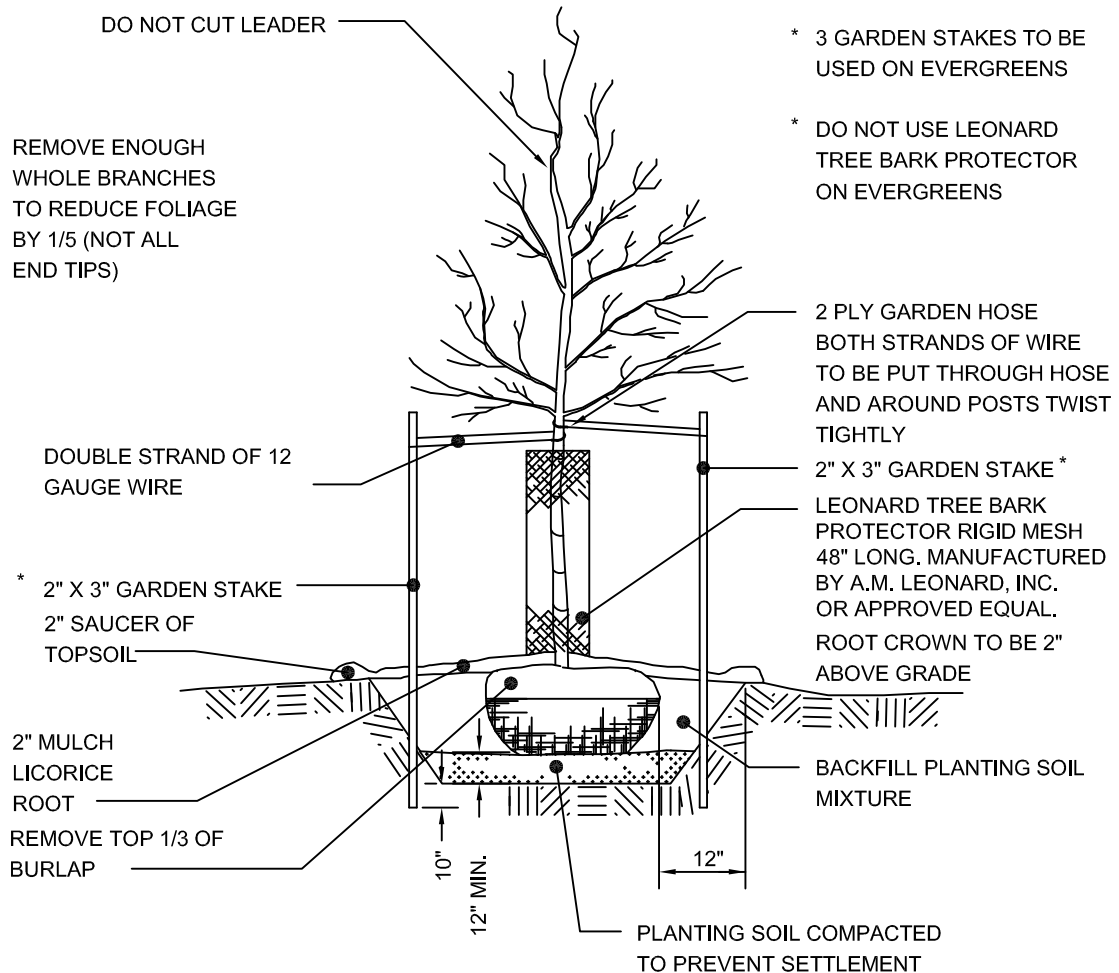

**UPPER DUBLIN TOWNSHIP STANDARD DETAIL
TREE PLANTING AND STAKING DETAIL**



DATE	10-2013	NOT TO SCALE	LS500
------	---------	--------------	-------

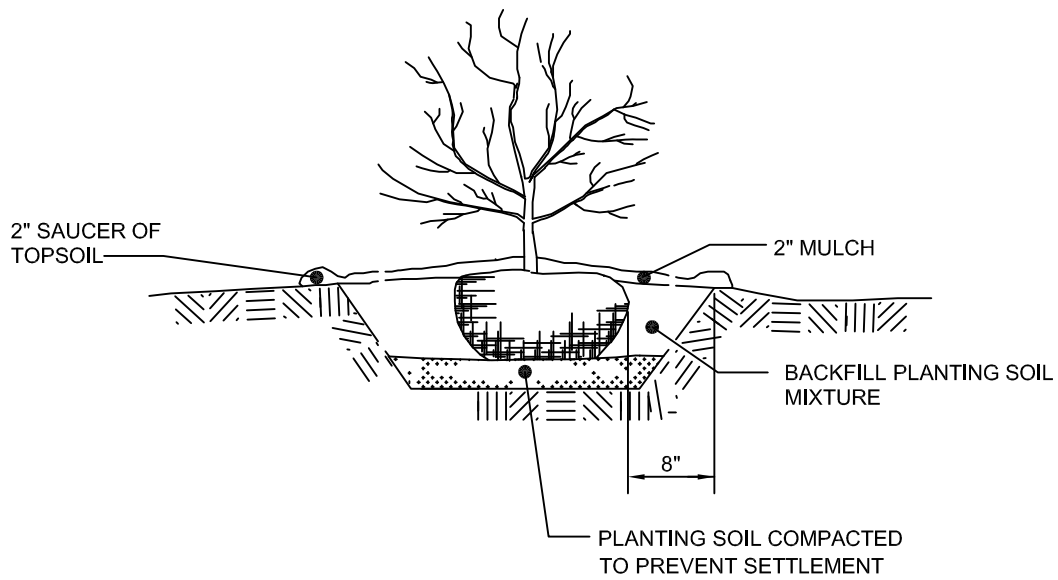

UPPER DUBLIN TOWNSHIP STANDARD DETAIL
SHRUB PLANTING DETAIL



DATE

10-2013

NOT TO SCALE

LS501



Finial: Decorative cast 356 aluminum, mechanically assembled.

Hood: Spun aluminum 1100-0 dome, permanently assembled to globe.

Globe: ACDR - One-piece, seamless, injected-molded impact-resistant (DR) acrylic globe having an inner prismatic surface with semi-prismatic house side shield and glare softening prisms on the street or (residential) side. The smooth external finish offers self-cleaning properties. The globe is mechanically assembled to the access mechanism.

Optical System: DSX3 - Type III assymetrical or (DSX5 - Type V symmetrical), cutoff distribution with less than 1% uplight. Smartseal Optical system, composed of bright-anodized hydroformed aluminum reflector, permanently assembled on a prismatic globe. Weatherproof IP66 rating.

Access-Mechanism: A cast A360.1 aluminum technical ring with latch and hinge. The mechanism shall offer toolfree access to the inside of the luminaire. An embedded memory-retentive gasket shall ensure weatherproofness.

Fitter: Cast aluminum A360.1 c/w 4 set screws 3/8-16 UNC. Fits on a 4" outside diameter by 4" long tenon.

**UPPER DUBLIN TOWNSHIP STANDARD DETAIL
RESIDENTIAL STREET LIGHT STANDARD (FIXTURE)**



DATE

10-2013

NOT TO SCALE

LS502

Pole Shaft: Shall be made from a mandrel formed aluminum tapered shaft, 12 fluted round, having a 0.125" wall thickness, welded to the pole base.

Joint Cover: One-piece round joint cover made from cast 356 aluminum, mechanically fastened with stainless steel screws.

Pole Base: Shall be made from a round fluted cast 356-T6 aluminum base having a 0.375" wall thickness, complete with a cast-in anchor plate.

Maintenance Opening: The pole shall have a 2 7/8" to 6" wide x 5 1/2" long maintenance opening centered 14" from the bottom of the anchor plate, complete with a weatherproof cast 356 aluminum cover and a copper ground lug.

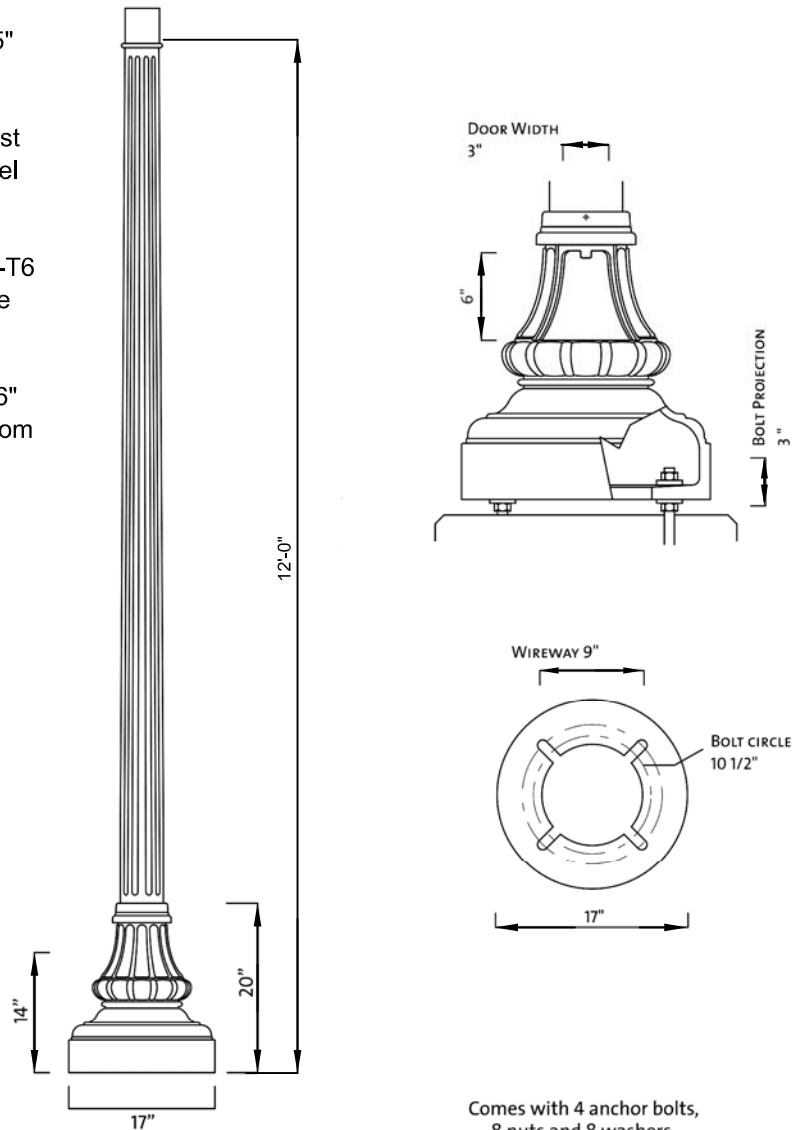

Comes with 4 anchor bolts,
8 nuts and 8 washers.
B.C. from: 10 1/2" to 12 1/2"

POLE/ BASE DETAIL

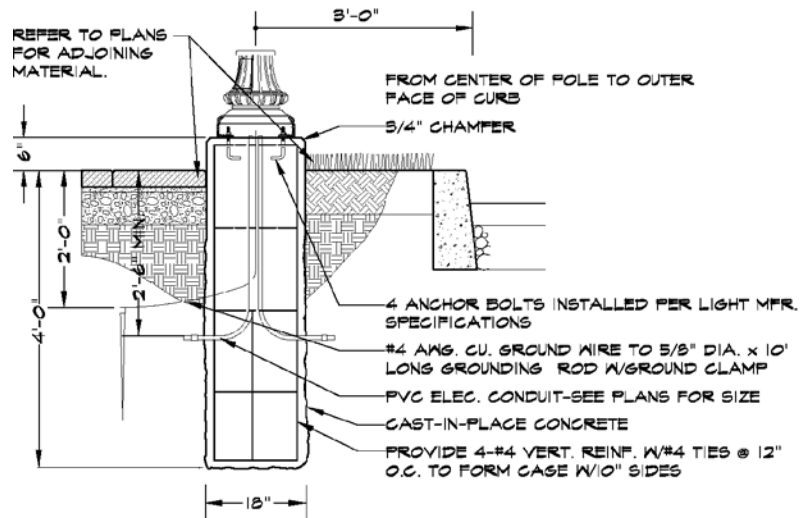

FOOTING DETAIL

**UPPER DUBLIN TOWNSHIP STANDARD DETAIL
RESIDENTIAL STREET LIGHT STANDARD (POLE, FOOTING)**



DATE

10-2013

NOT TO SCALE

LS503